

Technical Support Center: Enhancing Cellular Uptake of SOS1 Degraders

Author: BenchChem Technical Support Team. **Date:** April 2026

Compound of Interest

Compound Name: *SOS1 Ligand intermediate-6*

Cat. No.: *B15610193*

[Get Quote](#)

This technical support center provides researchers, scientists, and drug development professionals with troubleshooting guides and frequently asked questions (FAQs) to address common challenges encountered during experiments with SOS1 degraders.

Troubleshooting Guide

This section addresses specific issues you might encounter during your experiments, providing potential causes and solutions in a question-and-answer format.

Issue 1: Low or no degradation of SOS1 protein observed.

- Question: My Western blot shows no significant reduction in SOS1 protein levels after treating cells with my SOS1 degrader. What are the possible reasons and how can I troubleshoot this?
- Answer: Insufficient SOS1 degradation is a common issue that can stem from several factors. A systematic evaluation is crucial to pinpoint the problem.^[1]
 - Poor Cellular Permeability: Due to their high molecular weight, SOS1 degraders, like many PROTACs, often exhibit poor cell permeability.^{[2][3]}

- Solution: Consider modifying the degrader to enhance uptake. Strategies include conjugation with cell-penetrating peptides (CPPs) or employing reversible covalent chemistry.[4][5][6] You can also explore the use of prodrugs designed to improve cell permeability.[2]
- Inefficient Ternary Complex Formation: The degrader must effectively bring together SOS1 and the E3 ligase to form a stable ternary complex for ubiquitination to occur.[1][5]
 - Solution: Confirm target engagement of both SOS1 and the E3 ligase (e.g., Cereblon or VHL) using biophysical assays like Surface Plasmon Resonance (SPR) or in-cell assays like the Cellular Thermal Shift Assay (CETSA).[1][7] If binding is weak, linker optimization or modification of the warhead or E3 ligase ligand may be necessary.[5]
- "Hook Effect": At high concentrations, the degrader can form binary complexes with either SOS1 or the E3 ligase, preventing the formation of the productive ternary complex.[8]
 - Solution: Perform a dose-response experiment over a wide range of concentrations to identify the optimal concentration for degradation and to see if you are observing a "hook effect".[8]
- Proteasome Inhibition: If the proteasome is not functioning correctly, ubiquitinated SOS1 will not be degraded.
 - Solution: As a control, co-treat cells with your degrader and a proteasome inhibitor like MG132. If the degrader is working, you should see an accumulation of ubiquitinated SOS1 and a rescue of total SOS1 levels.[1][7]
- Cell Line Specific Factors: The expression levels of the target E3 ligase and components of the ubiquitin-proteasome system can vary between cell lines, affecting degrader efficiency.[9]
 - Solution: Measure the baseline expression of the recruited E3 ligase (e.g., CRBN) in your cell line. If expression is low, consider using a different cell line or a degrader that recruits a more abundant E3 ligase.

Issue 2: High off-target effects or cellular toxicity observed.

- Question: My SOS1 degrader is causing significant cell death or showing off-target protein degradation. How can I address this?
- Answer: Off-target effects and toxicity are critical concerns in drug development.[8]
 - Lack of Specificity: The degrader may be binding to and degrading proteins other than SOS1.
 - Solution: Perform global proteomics analysis to assess the specificity of your degrader. [9] If significant off-target degradation is observed, redesign of the SOS1-binding warhead may be required to improve selectivity.
 - On-Target Toxicity: In some cell lines, the degradation of SOS1 itself may be cytotoxic.
 - Solution: Titrate the degrader to the lowest effective concentration that achieves sufficient SOS1 degradation without causing excessive toxicity. You can also explore combination therapies, where a lower dose of the SOS1 degrader can be used with another agent, such as a MEK inhibitor, to achieve a synergistic anti-cancer effect.[10] [11]
 - E3 Ligase-Related Toxicity: Over-engagement of the E3 ligase could lead to unintended degradation of its natural substrates.
 - Solution: Design a negative control degrader with a mutated E3 ligase ligand that cannot bind to the ligase. This will help differentiate between SOS1-degradation-dependent toxicity and E3 ligase-related toxicity.

Frequently Asked Questions (FAQs)

This section provides answers to common questions about working with SOS1 degraders.

- Question 1: What is the mechanism of action for an SOS1 degrader?
- Answer: SOS1 degraders are typically proteolysis-targeting chimeras (PROTACs). These are bifunctional molecules with one end that binds to the SOS1 protein and the other end that binds to an E3 ubiquitin ligase (like Cereblon or VHL). This binding brings SOS1 and the E3

ligase into close proximity, leading to the ubiquitination of SOS1. The ubiquitin tags mark SOS1 for degradation by the cell's proteasome.[9][12][13]

- Question 2: How does degrading SOS1 affect cancer cells?
- Answer: SOS1 is a guanine nucleotide exchange factor (GEF) that activates RAS proteins, which are key drivers in many cancers.[14][15][16] By degrading SOS1, the activation of RAS is blocked, leading to the inhibition of downstream signaling pathways like the MAPK pathway.[10][17] This can suppress tumor cell proliferation and survival.[17][18] SOS1 degradation can be particularly effective in KRAS-mutant cancers.[7][9][12]
- Question 3: Which cell lines are suitable for SOS1 degrader experiments?
- Answer: Cell lines with known KRAS mutations are often good models, as they can be dependent on SOS1 for survival and proliferation.[19] Examples used in published studies include various colorectal cancer (CRC) cell lines (e.g., SW620, HCT116), pancreatic cancer cell lines (e.g., MIA PaCa-2), and non-small cell lung cancer (NSCLC) cell lines (e.g., NCI-H358).[7][9][17] It is important to select cell lines with adequate expression of the E3 ligase your degrader recruits.
- Question 4: What are some key quantitative parameters to measure the effectiveness of an SOS1 degrader?
- Answer: The following table summarizes key parameters:

Parameter	Description	Typical Assay
DC50	The concentration of the degrader that results in 50% degradation of the target protein.	Western Blot, High-Throughput (HiBiT) assays[20]
IC50	The concentration of the degrader that inhibits a biological process (e.g., cell proliferation) by 50%.	Cell Viability Assays (e.g., CellTiter-Glo)[16]
Dmax	The maximum level of protein degradation achieved.	Western Blot
t1/2 of degradation	The time required to achieve 50% of the maximal degradation.	Time-course Western Blot

- Question 5: How can I enhance the cellular uptake of my SOS1 degrader?
- Answer: Enhancing cellular uptake is a major challenge for PROTACs.[3] Some strategies include:
 - Linker Optimization: Modifying the linker can alter the physicochemical properties of the degrader, potentially improving its permeability.[5]
 - Reversible Covalent Chemistry: Incorporating a reversible covalent warhead can enhance intracellular accumulation.[5][6]
 - Nanoparticle Formulation: Encapsulating the degrader in nanoparticles can facilitate cellular entry.[4]
 - Cell-Penetrating Peptides (CPPs): Conjugating the degrader to a CPP can actively transport it across the cell membrane.[4]

Experimental Protocols

Protocol 1: Western Blot for SOS1 Degradation

This protocol details the steps to assess the degradation of SOS1 protein in cells treated with a degrader.

- Cell Seeding: Seed cells in a 6-well plate at a density that will result in 70-80% confluency at the time of harvest. Allow cells to attach overnight.
- Degradation Treatment: Treat cells with a serial dilution of the SOS1 degrader for a specified time (e.g., 24 hours). Include a vehicle control (e.g., DMSO).
- Cell Lysis:
 - Wash cells twice with ice-cold PBS.
 - Add 100-200 μ L of RIPA buffer containing protease and phosphatase inhibitors to each well.
 - Scrape the cells and transfer the lysate to a microcentrifuge tube.
 - Incubate on ice for 30 minutes, vortexing every 10 minutes.
 - Centrifuge at 14,000 rpm for 15 minutes at 4°C.
 - Collect the supernatant containing the protein lysate.
- Protein Quantification: Determine the protein concentration of each lysate using a BCA assay.
- Sample Preparation:
 - Normalize the protein concentration of all samples with lysis buffer.
 - Add 4x Laemmli sample buffer and boil at 95°C for 5 minutes.
- SDS-PAGE and Transfer:
 - Load equal amounts of protein (e.g., 20-30 μ g) onto an SDS-PAGE gel.
 - Run the gel to separate the proteins by size.

- Transfer the proteins to a PVDF membrane.
- Immunoblotting:
 - Block the membrane with 5% non-fat milk or BSA in TBST for 1 hour at room temperature.
 - Incubate the membrane with a primary antibody against SOS1 overnight at 4°C.
 - Wash the membrane three times with TBST.
 - Incubate with an HRP-conjugated secondary antibody for 1 hour at room temperature.
 - Wash the membrane three times with TBST.
- Detection:
 - Add ECL substrate to the membrane.
 - Visualize the bands using a chemiluminescence imaging system.
 - Also, probe for a loading control (e.g., β -actin or GAPDH) to ensure equal protein loading.
- Data Analysis: Quantify the band intensities and normalize the SOS1 signal to the loading control. Calculate the percentage of SOS1 degradation relative to the vehicle-treated control.

Protocol 2: Cell Viability Assay (CellTiter-Glo®)

This protocol measures the effect of an SOS1 degrader on cell proliferation.[\[16\]](#)

- Cell Seeding: Seed cells in a 96-well plate at an appropriate density (e.g., 2,000-5,000 cells/well) and allow them to attach overnight.[\[16\]](#)
- Inhibitor Treatment: Treat cells with a serial dilution of the SOS1 degrader for a specified period (e.g., 72 hours).[\[16\]](#) Include a vehicle control.
- Assay Procedure:
 - Equilibrate the plate and the CellTiter-Glo® reagent to room temperature.

- Add a volume of CellTiter-Glo® reagent equal to the volume of cell culture medium in each well.
- Mix the contents on an orbital shaker for 2 minutes to induce cell lysis.
- Incubate the plate at room temperature for 10 minutes to stabilize the luminescent signal.
- Data Analysis:
 - Measure luminescence using a plate reader.[16]
 - Calculate the percentage of cell viability relative to the vehicle-treated control.
 - Determine the IC50 value by performing a non-linear regression analysis.[16]

Visualizations

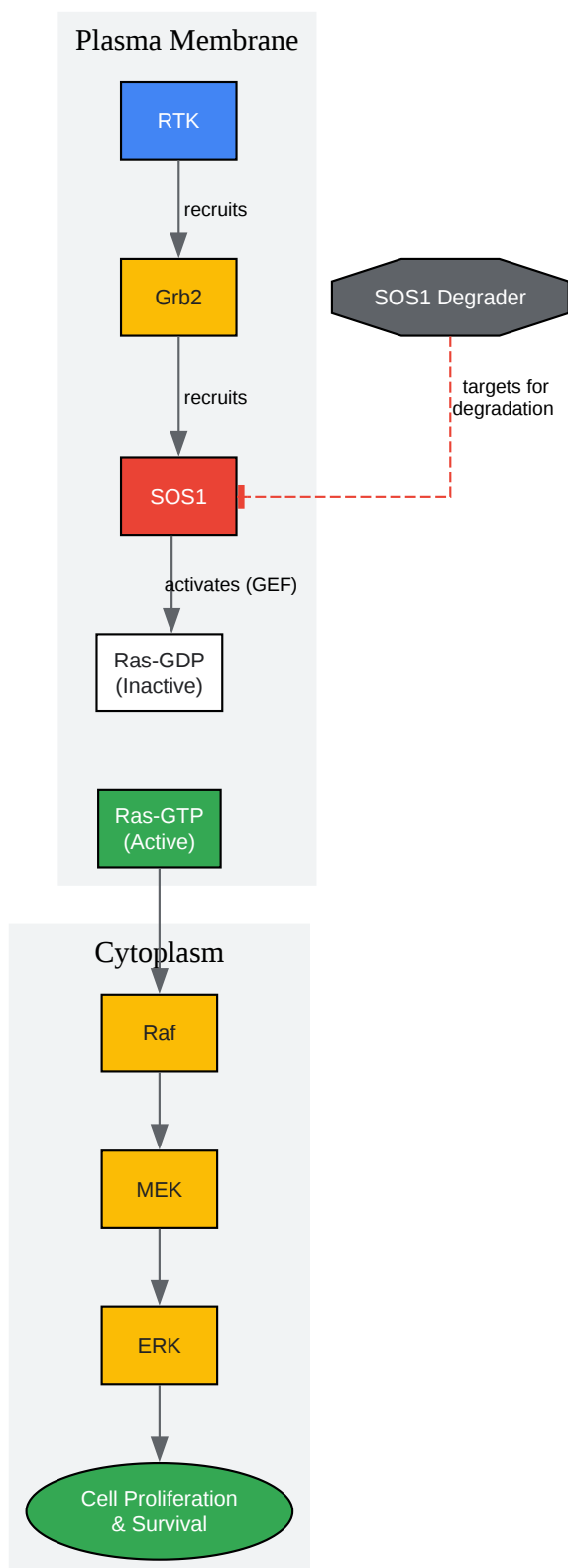

[Click to download full resolution via product page](#)

Caption: SOS1 signaling pathway and point of intervention by SOS1 degraders.

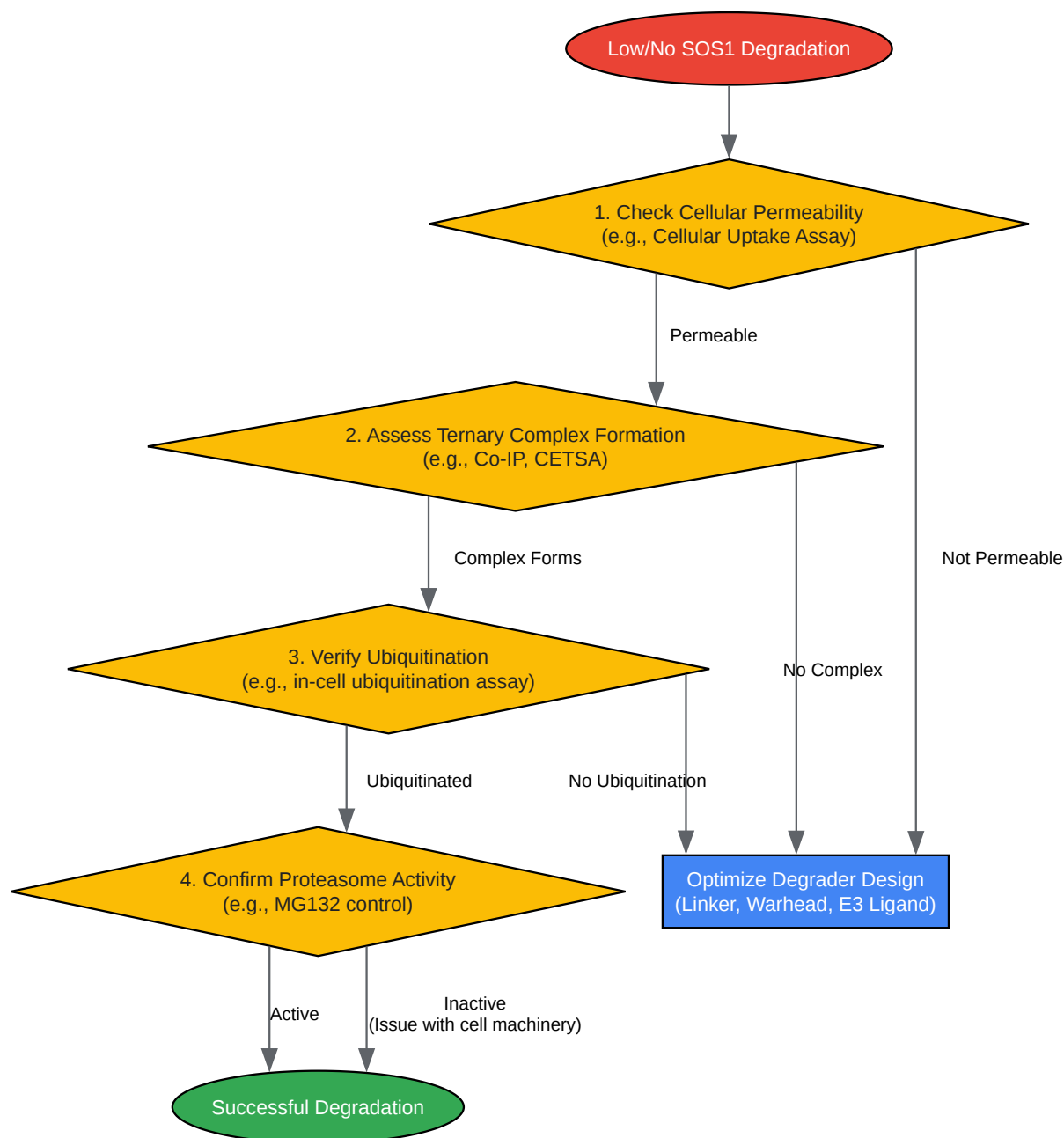

[Click to download full resolution via product page](#)

Need Custom Synthesis?

BenchChem offers custom synthesis for rare earth carbides and specific isotopic labeling.

Email: info@benchchem.com or [Request Quote Online](#).

References

- [1. benchchem.com \[benchchem.com\]](https://www.benchchem.com)
- [2. Novel Design Strategies to Enhance the Efficiency of Proteolysis Targeting Chimeras - PMC \[pmc.ncbi.nlm.nih.gov\]](https://pubmed.ncbi.nlm.nih.gov/)
- [3. From Conception to Development: Investigating PROTACs Features for Improved Cell Permeability and Successful Protein Degradation - PMC \[pmc.ncbi.nlm.nih.gov\]](https://pubmed.ncbi.nlm.nih.gov/)
- [4. Reductively activated CPP–PROTAC nanocomplexes enhance target degradation via efficient cellular uptake - PMC \[pmc.ncbi.nlm.nih.gov\]](https://pubmed.ncbi.nlm.nih.gov/)
- [5. biorxiv.org \[biorxiv.org\]](https://www.biorxiv.org/)
- [6. biorxiv.org \[biorxiv.org\]](https://www.biorxiv.org/)
- [7. aacrjournals.org \[aacrjournals.org\]](https://aacrjournals.org)
- [8. benchchem.com \[benchchem.com\]](https://www.benchchem.com)
- [9. Development of SOS1 inhibitor-based degraders to target KRAS-mutant colorectal cancer - PMC \[pmc.ncbi.nlm.nih.gov\]](https://pubmed.ncbi.nlm.nih.gov/)
- [10. SOS signaling in RAS-mutated cancers | Frederick National Laboratory \[frederick.cancer.gov\]](https://www.frederick.cancer.gov/)
- [11. cicancer.org \[cicancer.org\]](https://www.cicancer.org)
- [12. Development of PROTACS degrading KRAS and SOS1 - PMC \[pmc.ncbi.nlm.nih.gov\]](https://pubmed.ncbi.nlm.nih.gov/)
- [13. contractpharma.com \[contractpharma.com\]](https://www.contractpharma.com)
- [14. SOS1 gene: MedlinePlus Genetics \[medlineplus.gov\]](https://medlineplus.gov/)
- [15. SOS1 - Wikipedia \[en.wikipedia.org\]](https://en.wikipedia.org/)
- [16. benchchem.com \[benchchem.com\]](https://www.benchchem.com)
- [17. researchgate.net \[researchgate.net\]](https://www.researchgate.net)
- [18. Identification and characterization of oncogenic SOS1 mutations in lung adenocarcinoma - PMC \[pmc.ncbi.nlm.nih.gov\]](https://pubmed.ncbi.nlm.nih.gov/)

- [19. apps.dtic.mil \[apps.dtic.mil\]](https://apps.dtic.mil)
- [20. ascopubs.org \[ascopubs.org\]](https://ascopubs.org)
- To cite this document: BenchChem. [Technical Support Center: Enhancing Cellular Uptake of SOS1 Degraders]. BenchChem, [2026]. [Online PDF]. Available at: [\[https://www.benchchem.com/product/b15610193/docs#technical-support-center-enhancing-cellular-uptake-of-sos1-degraders\]](https://www.benchchem.com/product/b15610193/docs#technical-support-center-enhancing-cellular-uptake-of-sos1-degraders)

Disclaimer & Data Validity:

The information provided in this document is for Research Use Only (RUO) and is strictly not intended for diagnostic or therapeutic procedures. While BenchChem strives to provide accurate protocols, we make no warranties, express or implied, regarding the fitness of this product for every specific experimental setup.

Technical Support: The protocols provided are for reference purposes. Unsure if this reagent suits your experiment?

Need Industrial/Bulk Grade? [Request Custom Synthesis Quote](#)

BenchChem

Our mission is to be the trusted global source of essential and advanced chemicals, empowering scientists and researchers to drive progress in science and industry.

Contact

Address: 3281 E Guasti Rd
Ontario, CA 91761, United States
Phone: (601) 213-4426
Email: info@benchchem.com

[Contact our Ph.D. Support Team for a compatibility check](#)