

Application Notes and Protocols for GB1908, a Selective Galectin-1 Inhibitor

Author: BenchChem Technical Support Team. **Date:** April 2026

Compound of Interest

Compound Name: GB1908
Cat. No.: B15610762

[Get Quote](#)

For Researchers, Scientists, and Drug Development Professionals

These application notes provide detailed information and protocols for the experimental use of **GB1908**, a potent and selective, orally active inhibitor of galectin-1. This document outlines its solubility characteristics, preparation for in vitro and in vivo studies, and its application in cancer research, particularly in the context of lung cancer.

Introduction to GB1908

GB1908 is a small molecule glycomimetic that acts as a selective inhibitor of the carbohydrate recognition domain of galectin-1.[1] It has demonstrated high affinity for both human and mouse galectin-1, with over 50-fold selectivity against galectin-3.[2] By inhibiting galectin-1, **GB1908** can counteract its pro-tumorigenic and immune-suppressive functions, such as the induction of T-cell apoptosis.[1][3] This makes **GB1908** a valuable tool for investigating the role of galectin-1 in cancer biology and a potential therapeutic agent for cancers with high galectin-1 expression, including lung cancer, breast carcinoma, and metastatic skin cutaneous melanoma.[1][3]

Quantitative Data Summary

The following tables summarize the key quantitative data for **GB1908**.

Table 1: Binding Affinity and In Vitro Efficacy of **GB1908**

Parameter	Species	Value	Reference
Ki (Galectin-1)	Human	57 nM	[2]
Ki (Galectin-1)	Mouse	72 nM	[2]
Kd (Galectin-1)	Human	57 nM	[1]
Kd (Galectin-3)	Human	6.0 μ M	[1]
IC50 (Galectin-1-induced Jurkat cell apoptosis)	-	850 nM	[3]

Table 2: Solubility of **GB1908** for Experimental Use

Solvent System	Concentration	Result	Notes
10% DMSO, 40% PEG300, 5% Tween-80, 45% Saline	\geq 2.5 mg/mL (4.95 mM)	Clear solution	Suitable for in vivo administration.
10% DMSO, 90% (20% SBE- β -CD in Saline)	\geq 2.5 mg/mL (4.95 mM)	Clear solution	Suitable for in vivo administration.
10% DMSO, 90% Corn Oil	2.5 mg/mL (4.95 mM)	Suspended solution	Requires sonication. Suitable for oral and intraperitoneal injection.

Signaling Pathway of Galectin-1-Induced T-Cell Apoptosis

GB1908 inhibits the signaling pathway that leads to T-cell apoptosis mediated by galectin-1. The diagram below illustrates the key steps in this pathway.

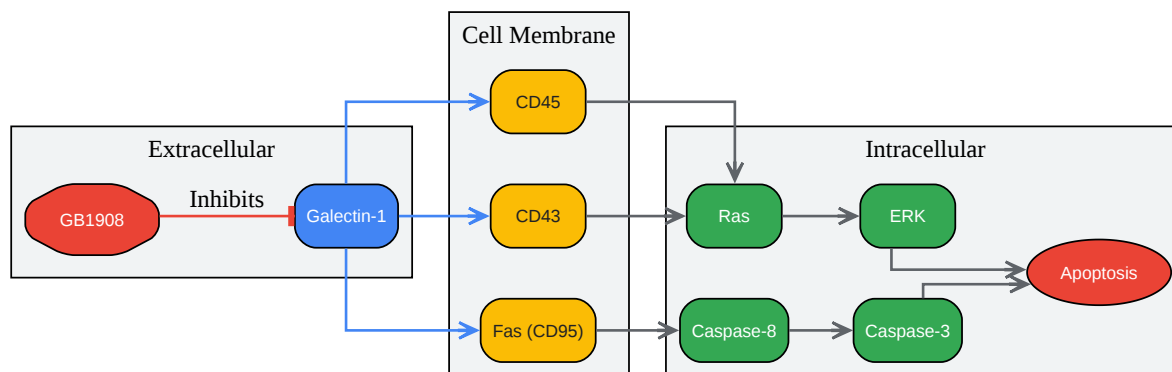

[Click to download full resolution via product page](#)

Caption: Galectin-1 signaling pathway leading to T-cell apoptosis and its inhibition by **GB1908**.

Experimental Protocols

Preparation of **GB1908** for In Vitro and In Vivo Use

The workflow for preparing **GB1908** solutions is outlined below.

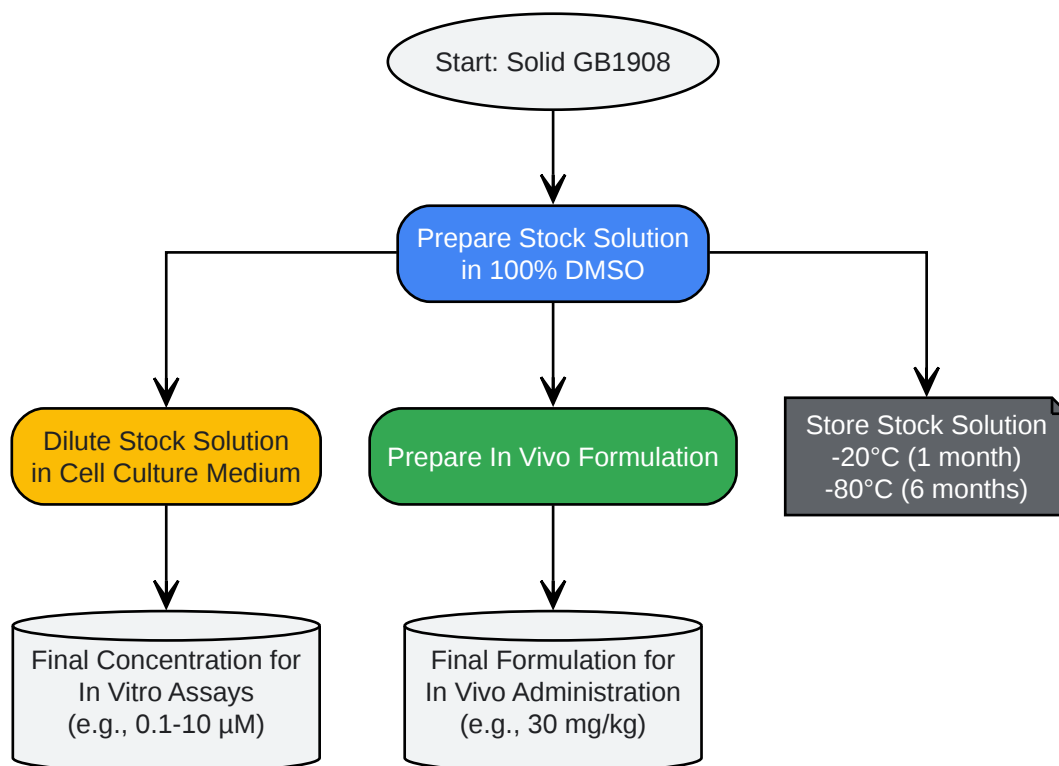

[Click to download full resolution via product page](#)

Caption: Workflow for the preparation of **GB1908** for experimental use.

Protocol for In Vivo Formulation (Example: 2.5 mg/mL Suspended Solution)

- Prepare a stock solution of **GB1908** in DMSO (e.g., 25 mg/mL).
- To prepare a 1 mL working solution, take 100 µL of the DMSO stock solution.
- Add 400 µL of PEG300 and mix thoroughly.
- Add 50 µL of Tween-80 and mix until uniform.
- Add 450 µL of saline to bring the final volume to 1 mL. This will result in a suspended solution of 2.5 mg/mL.
- If precipitation occurs, gentle heating and/or sonication can be used to aid dissolution.

Storage of Stock Solutions:

- Store aliquots of the DMSO stock solution at -20°C for up to 1 month or at -80°C for up to 6 months to avoid repeated freeze-thaw cycles.[2]

In Vitro Inhibition of Galectin-1-Induced T-Cell Apoptosis

This protocol describes how to assess the ability of **GB1908** to inhibit galectin-1-induced apoptosis in Jurkat T-cells.

Materials:

- Jurkat T-cells
- RPMI-1640 medium supplemented with 10% Fetal Bovine Serum (FBS)
- Recombinant human galectin-1
- **GB1908**
- Annexin V-FITC Apoptosis Detection Kit
- Propidium Iodide (PI)
- Flow cytometer

Protocol:

- Cell Culture: Culture Jurkat T-cells in RPMI-1640 supplemented with 10% FBS at 37°C in a humidified atmosphere with 5% CO₂.
- Treatment:
 - Seed Jurkat cells at a density of 1×10^6 cells/mL in a 24-well plate.
 - Pre-incubate the cells with varying concentrations of **GB1908** (e.g., 0.1-10 μ M) for 1 hour.
 - Induce apoptosis by adding recombinant human galectin-1 to a final concentration known to induce apoptosis in Jurkat cells.

- Include appropriate controls: untreated cells, cells treated with galectin-1 only, and cells treated with **GB1908** only.
- Incubate the cells for 16 hours.[2]
- Apoptosis Analysis by Flow Cytometry:
 - Harvest the cells and wash them twice with cold PBS.
 - Resuspend the cells in 1X Annexin V binding buffer.
 - Add Annexin V-FITC and Propidium Iodide to the cell suspension according to the manufacturer's instructions.
 - Incubate the cells in the dark for 15 minutes at room temperature.
 - Analyze the samples by flow cytometry. Live cells will be negative for both Annexin V and PI, early apoptotic cells will be Annexin V positive and PI negative, and late apoptotic/necrotic cells will be positive for both.

In Vivo Antitumor Efficacy in a Syngeneic Mouse Model of Lung Cancer

This protocol outlines the use of **GB1908** in a Lewis Lung Carcinoma (LL/2) syngeneic mouse model.

Materials:

- Female C57BL/6N mice (6-8 weeks old)
- LL/2 (LLC1) Lewis lung carcinoma cells
- **GB1908**
- Vehicle for in vivo administration (e.g., PEG300/Solutol HS15/Tween 20 solution (85/15/1% v/v))[4]
- Calipers for tumor measurement

Protocol:

- Tumor Cell Implantation:
 - Culture LL/2 cells to ~80% confluency.
 - Harvest and resuspend the cells in sterile PBS.
 - Subcutaneously inject 1×10^6 LL/2 cells in a volume of 100 μ L into the flank of each C57BL/6N mouse.[5]
- Treatment:
 - Once tumors are palpable and have reached a predetermined size, randomize the mice into treatment and control groups.
 - Administer **GB1908** orally (p.o.) at a dose of 30 mg/kg, twice a day.[2]
 - Administer the vehicle solution to the control group following the same schedule.
 - Continue treatment for 21 days.[2]
- Tumor Growth Monitoring:
 - Measure tumor dimensions using calipers every 2-3 days.
 - Calculate tumor volume using the formula: $(\text{Length} \times \text{Width}^2) / 2$.
 - Monitor the body weight and overall health of the mice throughout the study.
- Endpoint:
 - At the end of the study, euthanize the mice and excise the tumors for further analysis (e.g., weight, histology, or biomarker analysis).

These protocols provide a foundation for utilizing **GB1908** in cancer research. Investigators should optimize these methods for their specific experimental conditions and adhere to all relevant institutional and national guidelines for animal care and use.

Need Custom Synthesis?

BenchChem offers custom synthesis for rare earth carbides and specific isotopic labeling.

Email: info@benchchem.com or [Request Quote Online](#).

References

- [1. pubs.acs.org \[pubs.acs.org\]](https://pubs.acs.org)
- [2. Discovery of the Selective and Orally Available Galectin-1 Inhibitor GB1908 as a Potential Treatment for Lung Cancer - PubMed \[pubmed.ncbi.nlm.nih.gov\]](#)
- [3. researchgate.net \[researchgate.net\]](https://www.researchgate.net)
- [4. Galectin-8 Induces Apoptosis in Jurkat T Cells by Phosphatidic Acid-mediated ERK1/2 Activation Supported by Protein Kinase A Down-regulation - PMC \[pmc.ncbi.nlm.nih.gov\]](#)
- [5. LL2 Allograft Model - Altogen Labs \[altogenlabs.com\]](https://www.altogenlabs.com)
- To cite this document: BenchChem. [Application Notes and Protocols for GB1908, a Selective Galectin-1 Inhibitor]. BenchChem, [2026]. [Online PDF]. Available at: [\[https://www.benchchem.com/product/b15610762/docs#application-notes-and-protocols-for-gb1908-a-selective-galectin-1-inhibitor\]](https://www.benchchem.com/product/b15610762/docs#application-notes-and-protocols-for-gb1908-a-selective-galectin-1-inhibitor)

Disclaimer & Data Validity:

The information provided in this document is for Research Use Only (RUO) and is strictly not intended for diagnostic or therapeutic procedures. While BenchChem strives to provide accurate protocols, we make no warranties, express or implied, regarding the fitness of this product for every specific experimental setup.

Technical Support: The protocols provided are for reference purposes. Unsure if this reagent suits your experiment?

Need Industrial/Bulk Grade? [Request Custom Synthesis Quote](#)

BenchChem

Our mission is to be the trusted global source of essential and advanced chemicals, empowering scientists and researchers to drive progress in science and industry.

Contact

Address: 3281 E Guasti Rd

Ontario, CA 91761, United States

Phone: (601) 213-4426

Email: info@benchchem.com

[Contact our Ph.D. Support Team for a compatibility check](#)