

# Application Notes and Protocols: GNE-220

## HUVEC Sprouting Assay

**Author:** BenchChem Technical Support Team. **Date:** April 2026

### Compound of Interest

Compound Name: GNE 220  
Cat. No.: B15610907

[Get Quote](#)

## For Researchers, Scientists, and Drug Development Professionals

These application notes provide a detailed protocol for assessing the anti-angiogenic potential of GNE-220, a hypothetical small molecule inhibitor, using a human umbilical vein endothelial cell (HUVEC) spheroid sprouting assay. This document outlines the experimental workflow, data analysis, and expected outcomes, offering a comprehensive guide for researchers in angiogenesis and drug discovery.

## Introduction

Angiogenesis, the formation of new blood vessels from pre-existing ones, is a critical process in both normal physiological functions and pathological conditions such as tumor growth and metastasis. The HUVEC spheroid sprouting assay is a robust in vitro model that recapitulates key steps of angiogenesis, including endothelial cell migration, proliferation, and tube formation. GNE-220 is an investigational compound designed to target key signaling pathways in endothelial cells, thereby inhibiting angiogenesis. This document provides the methodology to evaluate the efficacy of GNE-220 in this assay.

## Hypothetical Mechanism of Action of GNE-220

GNE-220 is postulated to be a potent inhibitor of Vascular Endothelial Growth Factor Receptor 2 (VEGFR2), a primary mediator of angiogenic signaling. Upon binding of its ligand, VEGF-A, VEGFR2 dimerizes and autophosphorylates, initiating a downstream cascade involving key signaling nodes such as PLC $\gamma$ , PI3K, and MAPK. This cascade ultimately leads to endothelial cell proliferation, migration, and survival. GNE-220 is thought to competitively bind to the ATP-binding site of the VEGFR2 tyrosine kinase domain, preventing its activation and subsequent downstream signaling.

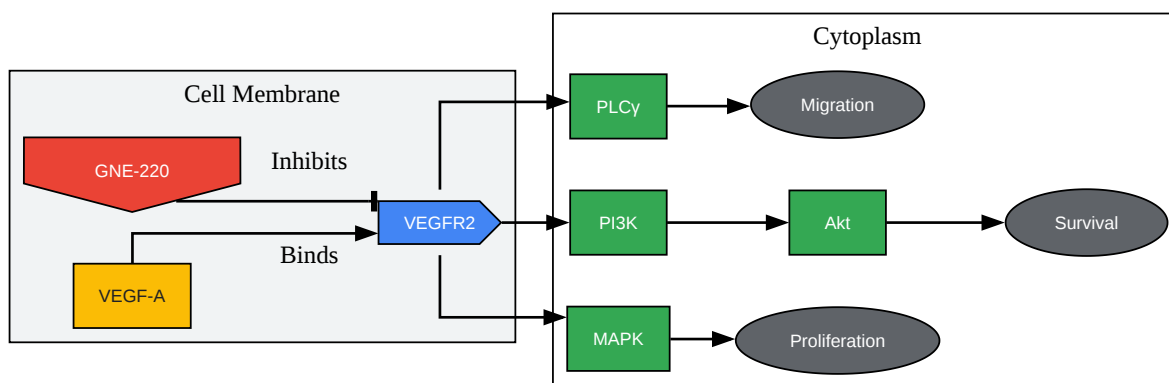

[Click to download full resolution via product page](#)

**Caption:** Proposed mechanism of GNE-220 action.

## Experimental Protocol: HUVEC Spheroid Sprouting Assay

This protocol details the steps for generating HUVEC spheroids and assessing the anti-sprouting effect of GNE-220.

### Materials and Reagents

- Human Umbilical Vein Endothelial Cells (HUVECs)

- Endothelial Cell Growth Medium (EGM-2)
- Fetal Bovine Serum (FBS)
- Trypsin-EDTA
- Phosphate Buffered Saline (PBS)
- Methylcellulose stock solution (1.2% in EGM-2)
- Collagen I, rat tail
- VEGF-A (recombinant human)
- GNE-220 (stock solution in DMSO)
- 96-well round-bottom ultra-low attachment plates
- 24-well tissue culture plates

## Experimental Workflow Diagram

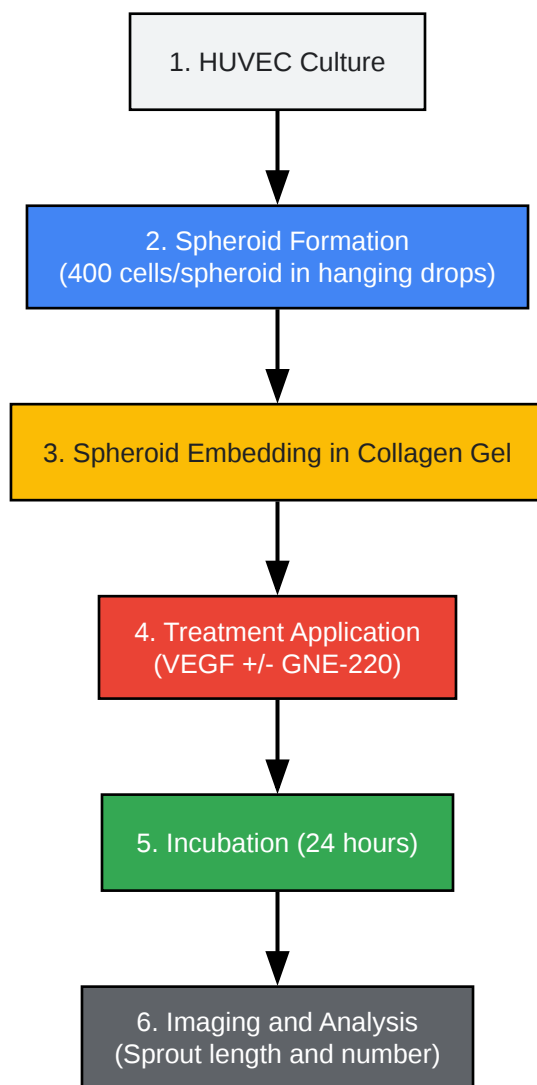

[Click to download full resolution via product page](#)

**Caption:** HUVEC spheroid sprouting assay workflow.

## Step-by-Step Procedure

- HUVEC Culture: Culture HUVECs in EGM-2 medium supplemented with 2% FBS. Maintain cells in a humidified incubator at 37°C and 5% CO<sub>2</sub>. Use cells at passage 3-6 for experiments.
- Spheroid Formation:
  - Trypsinize confluent HUVECs and resuspend in EGM-2 containing 20% methylcellulose to a final concentration of  $2 \times 10^4$  cells/mL.

- Pipette 20  $\mu$ L drops of the cell suspension onto the lid of a 10 cm petri dish, creating hanging drops.
- Add PBS to the bottom of the dish to maintain humidity and incubate for 24 hours to allow spheroid formation.
- Spheroid Embedding:
  - Prepare a collagen gel solution on ice by mixing Collagen I, 10x PBS, and sterile water to a final concentration of 2.5 mg/mL. Neutralize the solution with 1N NaOH.
  - Gently harvest the spheroids from the hanging drops and resuspend them in the neutralized collagen solution.
  - Dispense 100  $\mu$ L of the spheroid-collagen mixture into each well of a pre-chilled 24-well plate.
  - Incubate the plate at 37°C for 30 minutes to allow for collagen polymerization.
- Treatment Application:
  - Prepare treatment media containing EGM-2 with 2% FBS and the desired concentrations of VEGF-A (e.g., 25 ng/mL) and GNE-220 (e.g., 0.1, 1, 10, 100 nM). Include a vehicle control (DMSO).
  - Carefully add 500  $\mu$ L of the respective treatment media on top of the polymerized collagen gel.
- Incubation: Incubate the plate for 24 hours at 37°C and 5% CO<sub>2</sub> to allow for endothelial sprouting.
- Imaging and Analysis:
  - After 24 hours, visualize the spheroids using a phase-contrast microscope.
  - Capture images of at least 10 representative spheroids per condition.

- Quantify the angiogenic response by measuring the cumulative sprout length and the number of primary sprouts per spheroid using image analysis software (e.g., ImageJ).

## Data Presentation and Analysis

The anti-angiogenic effect of GNE-220 is determined by its ability to inhibit VEGF-A-induced sprouting. The quantitative data should be summarized to compare the different treatment groups.

**Table 1: Effect of GNE-220 on HUVEC Sprouting (Hypothetical Data)**

Treatment Group	GNE-220 Conc. (nM)	Mean Cumulative Sprout Length ( $\mu\text{m}$ ) $\pm$ SD	Mean Number of Sprouts $\pm$ SD	% Inhibition of Sprout Length
Vehicle Control	0	50.3 $\pm$ 8.2	2.1 $\pm$ 0.8	-
VEGF-A (25 ng/mL)	0	452.8 $\pm$ 45.1	15.4 $\pm$ 2.3	0
VEGF-A + GNE-220	0.1	380.1 $\pm$ 39.5	12.8 $\pm$ 2.1	16.1%
VEGF-A + GNE-220	1	225.7 $\pm$ 31.2	8.3 $\pm$ 1.5	50.2%
VEGF-A + GNE-220	10	98.4 $\pm$ 15.6	4.1 $\pm$ 1.1	78.3%
VEGF-A + GNE-220	100	55.2 $\pm$ 9.8	2.5 $\pm$ 0.9	87.8%

Data are represented as mean  $\pm$  standard deviation (SD) from a representative experiment with n=10 spheroids per group.

## Data Interpretation

The hypothetical data presented in Table 1 suggests that GNE-220 inhibits VEGF-A-induced HUVEC sprouting in a dose-dependent manner. The IC50 value, the concentration of GNE-220 that inhibits 50% of the sprouting activity, can be calculated from this data, providing a quantitative measure of the compound's potency.

## Conclusion

The HUVEC spheroid sprouting assay is a valuable tool for evaluating the anti-angiogenic properties of novel compounds like GNE-220. The detailed protocol and data presentation format provided in these application notes offer a standardized approach for assessing the efficacy and potency of angiogenesis inhibitors. The hypothetical results indicate that GNE-220 is a potent inhibitor of in vitro angiogenesis, warranting further investigation into its therapeutic potential.

- To cite this document: BenchChem. [Application Notes and Protocols: GNE-220 HUVEC Sprouting Assay]. BenchChem, [2026]. [Online PDF]. Available at: [<https://www.benchchem.com/product/b15610907/docs#application-notes-and-protocols-gne-220-huvec-sprouting-assay>]

---

### Disclaimer & Data Validity:

The information provided in this document is for Research Use Only (RUO) and is strictly not intended for diagnostic or therapeutic procedures. While BenchChem strives to provide accurate protocols, we make no warranties, express or implied, regarding the fitness of this product for every specific experimental setup.

**Technical Support:** The protocols provided are for reference purposes. Unsure if this reagent suits your experiment?

**Need Industrial/Bulk Grade?** [Request Custom Synthesis Quote](#)

# BenchChem

Our mission is to be the trusted global source of essential and advanced chemicals, empowering scientists and researchers to drive progress in science and industry.

## Contact

Address: 3281 E Guasti Rd

Ontario, CA 91761, United States

Phone: (601) 213-4426

Email: [info@benchchem.com](mailto:info@benchchem.com)

[Contact our Ph.D. Support Team for a compatibility check](#)