

Application Note: Measuring Amplifier Input Impedance using the VB1080 VSWR Bridge

Author: BenchChem Technical Support Team. **Date:** April 2026

Compound of Interest

Compound Name: VB1080
Cat. No.: B15610365

[Get Quote](#)

Introduction

The input impedance of an amplifier is a critical parameter that dictates the power transfer from the source and the overall signal integrity of an RF system. A well-matched input impedance to the characteristic impedance of the system (typically 50 Ω) is crucial for minimizing signal reflection and maximizing power delivery to the amplifier. This application note provides a detailed protocol for measuring the input impedance of an RF amplifier in the 2 GHz to 8 GHz frequency range using the Rigol **VB1080** VSWR (Voltage Standing Wave Ratio) bridge in conjunction with a Rigol DSA series spectrum analyzer with a tracking generator. This method allows for the characterization of the amplifier's input impedance across its operating frequency band, providing valuable insights for researchers, scientists, and drug development professionals working with RF systems.

Theoretical Background

The input impedance (Z_{in}) of a device can be determined by measuring its reflection coefficient (Γ), which is a complex quantity that describes the amplitude and phase of the signal reflected from the device's input. The reflection coefficient is often expressed as the S-

parameter S11. The **VB1080** is a VSWR bridge that, when used with a spectrum analyzer and its tracking generator, facilitates the measurement of S11.

The relationship between the input impedance (Z_{in}), the characteristic impedance of the measurement system (Z_0 , typically 50 Ω), and the reflection coefficient (S11) is given by the following formula:

$$Z_{in} = Z_0 * (1 + S11) / (1 - S11)$$

Where:

- Z_{in} is the complex input impedance ($R + jX$)
- Z_0 is the characteristic impedance of the system (50 Ω)
- S11 is the complex reflection coefficient (magnitude and phase)

The spectrum analyzer measures the magnitude of S11 in decibels (dB), which is the return loss. To use the above formula, the S11 magnitude in dB must be converted to a linear format, and the phase of S11 must also be measured. Modern spectrum analyzers with vector network analysis capabilities can directly provide the complex S11 value.

Experimental Setup

A precise experimental setup is crucial for accurate and repeatable measurements. The following diagram illustrates the connections for measuring the input impedance of an amplifier using the **VB1080**.

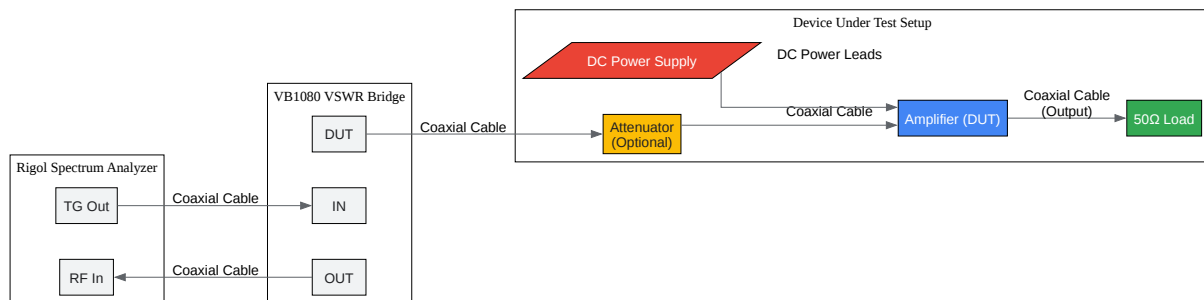

[Click to download full resolution via product page](#)

Figure 1: Experimental setup for amplifier input impedance measurement.

Equipment and Materials:

- Rigol DSA Series Spectrum Analyzer with Tracking Generator (TG)
- Rigol **VB1080** VSWR Bridge (2 GHz - 8 GHz)
- Amplifier to be tested (Device Under Test - DUT)
- 50 Ω Coaxial Cables with N-type connectors
- 50 Ω Load Termination (rated for the amplifier's output power)
- DC Power Supply for the amplifier
- Coaxial Attenuator (optional, see protocol)

- Calibration Kit (Open, Short, Load)

Experimental Protocols

This section provides a step-by-step protocol for measuring the input impedance of an amplifier using the **VB1080**.

Instrument and DUT Preparation

- Warm-up: Turn on the spectrum analyzer and allow it to warm up for at least 30 minutes to ensure stable operation.
- Amplifier Power Off: Ensure the DC power to the amplifier (DUT) is turned off before making any connections.
- Output Termination: Connect a 50 Ω load termination to the output of the amplifier. This is critical to ensure the amplifier is properly terminated and to prevent oscillations or damage. The load should be rated to handle the potential output power of the amplifier.

Calibration Procedure (Open, Short, Load)

Calibration is a critical step to remove the systematic errors from the measurement setup, such as the effects of cables and the VSWR bridge itself.

- Connect the **VB1080**: Connect the **VB1080** to the spectrum analyzer. Connect the Tracking Generator (TG) output to the 'IN' port of the **VB1080** and the RF Input to the 'OUT' port of the **VB1080** using coaxial cables.
- Initiate Calibration: On the spectrum analyzer, enter the S11 measurement mode (often part of a Vector Network Analyzer or VNA option). Initiate the one-port calibration routine.
- Open Calibration: When prompted, leave the 'DUT' port of the **VB1080** open to the air. Allow the spectrum analyzer to perform the open measurement.
- Short Calibration: When prompted, connect a high-quality shorting standard to the 'DUT' port of the **VB1080**. Allow the spectrum analyzer to perform the short measurement.

- **Load Calibration:** When prompted, connect a high-quality 50 Ω load standard to the 'DUT' port of the **VB1080**. Allow the spectrum analyzer to perform the load measurement.
- **Complete Calibration:** After all three measurements are complete, the spectrum analyzer will calculate and apply the error correction terms.

Amplifier Input Impedance Measurement

- **Connect the Amplifier:** Connect the input of the amplifier to the 'DUT' port of the **VB1080**.
 - **Optional Attenuator:** If there is a concern that the amplifier might oscillate or that its gain might cause a reflection that could overload the spectrum analyzer's input, an attenuator (e.g., 3 dB or 6 dB) can be placed between the 'DUT' port and the amplifier's input. If an attenuator is used, the calibration should ideally be performed at the end of the attenuator for the highest accuracy.
- **Power On the Amplifier:** Turn on the DC power supply for the amplifier and set the correct voltage and current limit.
- **Set Spectrum Analyzer Parameters:**
 - **Frequency Range:** Set the start and stop frequencies on the spectrum analyzer to cover the operating range of the amplifier.
 - **Tracking Generator Power:** Set the tracking generator output power to a level that is within the linear operating range of the amplifier. A low power level (e.g., -20 dBm) is typically a good starting point to avoid compressing the amplifier.
 - **Measurement Format:** Select the desired measurement format. To obtain the complex impedance, you will need to measure both the magnitude (in dB) and phase of S11. Many modern spectrum analyzers can display the impedance directly on a Smith Chart or in a table of R + jX values.
- **Acquire Data:** Allow the spectrum analyzer to sweep across the specified frequency range and record the S11 data.

- **Data Extraction:** Save the S11 data (magnitude and phase) or the calculated impedance values across the frequency range. Most spectrum analyzers allow exporting the data to a CSV file for further analysis.

Data Presentation

The measured data should be presented in a clear and organized manner to facilitate analysis and comparison.

Table 1: Amplifier Input Impedance Data

Frequency (GHz)	S11 Magnitude (dB)	S11 Phase (degrees)	Input Impedance (R + jX Ω)
2.0	-15.2	-175.3	48.5 - j2.1
2.5	-18.5	160.1	51.2 + j3.5
3.0	-20.1	145.8	50.8 + j5.2
3.5	-17.9	120.4	49.1 + j7.8
4.0	-14.5	95.2	47.3 + j10.5
...
8.0	-10.1	-30.7	42.1 - j15.3

In addition to a tabular format, a Smith Chart is an excellent graphical tool for visualizing the input impedance of the amplifier over its frequency range.

Logical Workflow

The following diagram illustrates the logical workflow of the entire measurement process.

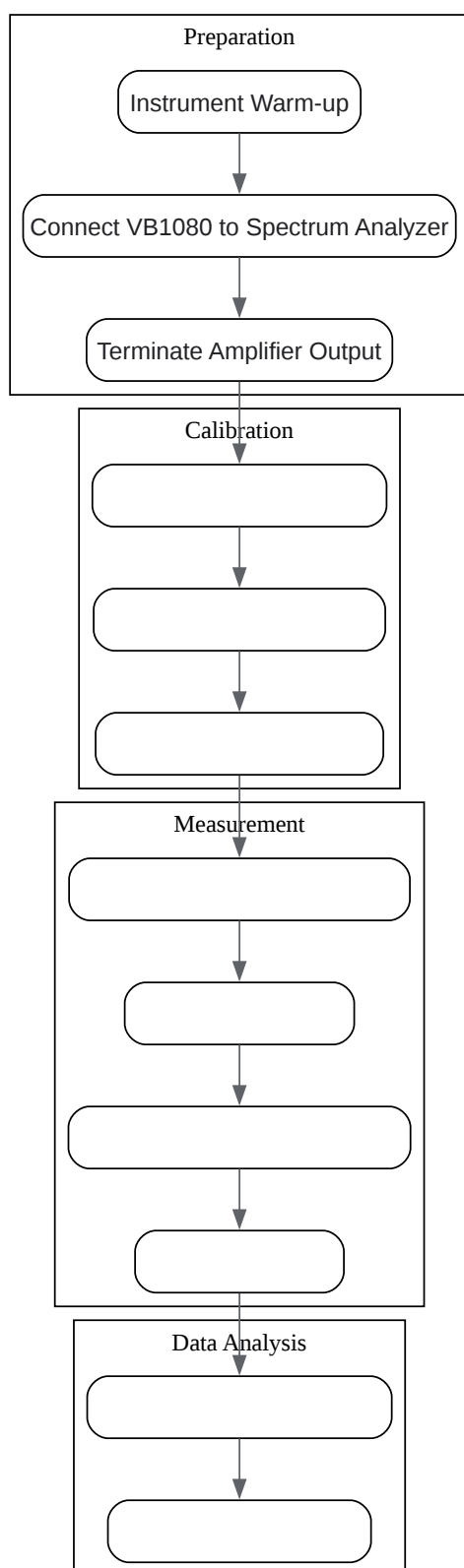

[Click to download full resolution via product page](#)

Figure 2: Measurement workflow from preparation to data analysis.

Conclusion

This application note has provided a comprehensive protocol for measuring the input impedance of an RF amplifier using the Rigol **VB1080** VSWR bridge and a spectrum analyzer. By following the detailed experimental setup, calibration procedure, and measurement steps, researchers and engineers can accurately characterize the input impedance of their amplifiers. This information is essential for designing matching networks, ensuring system stability, and optimizing the overall performance of RF systems.

- To cite this document: BenchChem. [Application Note: Measuring Amplifier Input Impedance using the VB1080 VSWR Bridge]. BenchChem, [2026]. [Online PDF]. Available at: [\[https://www.benchchem.com/product/b15610365/docs#application-note-measuring-amplifier-input-impedance-using-the-vb1080-vswr-bridge\]](https://www.benchchem.com/product/b15610365/docs#application-note-measuring-amplifier-input-impedance-using-the-vb1080-vswr-bridge)

Disclaimer & Data Validity:

The information provided in this document is for Research Use Only (RUO) and is strictly not intended for diagnostic or therapeutic procedures. While BenchChem strives to provide accurate protocols, we make no warranties, express or implied, regarding the fitness of this product for every specific experimental setup.

Technical Support: The protocols provided are for reference purposes. Unsure if this reagent suits your experiment?

Need Industrial/Bulk Grade? [Request Custom Synthesis Quote](#)

BenchChem

Our mission is to be the trusted global source of essential and advanced chemicals, empowering scientists and researchers to drive progress in science and industry.

Contact

Address: 3281 E Guasti Rd
Ontario, CA 91761, United States
Phone: (601) 213-4426
Email: info@benchchem.com

Contact our Ph.D. Support Team for a compatibility check