

An In-depth Technical Guide to the Mechanism of Action of Modzatinib

Author: BenchChem Technical Support Team. **Date:** April 2026

Compound of Interest

Compound Name:	Modzatinib
CAS No.:	2411407-25-3
Cat. No.:	B15610401

[Get Quote](#)

For Researchers, Scientists, and Drug Development Professionals

Introduction

Modzatinib is an investigational small molecule inhibitor targeting key signaling pathways implicated in oncogenesis and tumor proliferation. This document provides a comprehensive overview of the current understanding of **Modzatinib**'s mechanism of action, drawing from available preclinical and clinical data. The information is intended to serve as a technical guide for professionals in the field of cancer research and drug development.

Note on Data Availability: As of the latest literature review, specific quantitative data from dedicated studies on **Modzatinib**'s binding affinities, IC50 values across various cell lines, and detailed pharmacokinetic/pharmacodynamic profiles are not publicly available. The information presented herein is based on the broader understanding of its putative target class and the general mechanisms of similar kinase inhibitors. This guide will be updated as more specific data on **Modzatinib** becomes available.

Core Mechanism of Action: Targeting Receptor Tyrosine Kinases

Modzatinib is hypothesized to function as a potent and selective inhibitor of one or more receptor tyrosine kinases (RTKs). RTKs are crucial cell surface receptors that control a wide array of fundamental cellular processes, including growth, differentiation, metabolism, and motility. In many cancers, these kinases are constitutively activated due to mutations, gene amplification, or autocrine/paracrine signaling loops, leading to uncontrolled cell proliferation and survival.

The binding of a ligand to the extracellular domain of an RTK induces receptor dimerization and subsequent autophosphorylation of specific tyrosine residues in the intracellular domain. This phosphorylation creates docking sites for various downstream signaling proteins, initiating a cascade of intracellular events that ultimately drive cellular responses.

Modzatinib is designed to competitively bind to the ATP-binding pocket of the kinase domain, preventing the phosphorylation of tyrosine residues and thereby blocking the downstream signaling pathways.

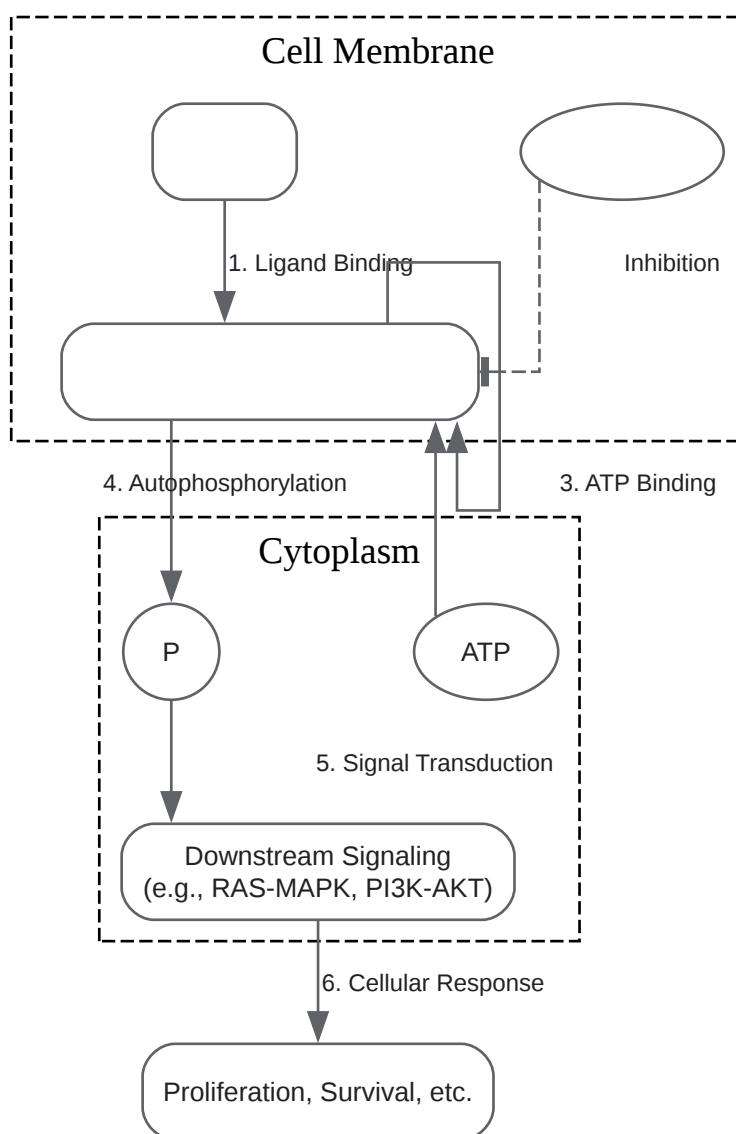

[Click to download full resolution via product page](#)

Figure 1: Generalized signaling pathway of a Receptor Tyrosine Kinase (RTK) and the inhibitory action of **Modzatinib**.

Experimental Protocols for Elucidating the Mechanism of Action

To rigorously define the mechanism of action of a novel kinase inhibitor like **Modzatinib**, a series of established experimental protocols are typically employed. These assays are designed to assess its biochemical potency, cellular activity, and in vivo efficacy.

Biochemical Assays

- Kinase Inhibition Assays: These in vitro assays are fundamental to determining the inhibitory activity of **Modzatinib** against a panel of purified kinases.
 - Methodology: A common method is the ADP-Glo™ Kinase Assay. This luminescent assay quantifies the amount of ADP produced during a kinase reaction. The kinase, substrate, ATP, and varying concentrations of **Modzatinib** are incubated together. After the reaction, a reagent is added to stop the kinase reaction and deplete the remaining ATP. A second reagent is then added to convert the produced ADP into ATP, which is subsequently used in a luciferase/luciferin reaction to generate a light signal. The intensity of the light is proportional to the kinase activity. The IC50 value, the concentration of inhibitor required to reduce enzyme activity by 50%, is then calculated.

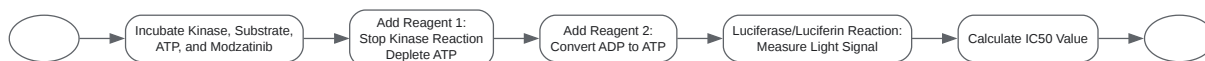

[Click to download full resolution via product page](#)

Figure 2: Workflow for a typical in vitro kinase inhibition assay.

Cell-Based Assays

- Cell Viability and Proliferation Assays: These assays determine the effect of **Modzatinib** on the growth and survival of cancer cell lines.
 - Methodology: The MTT (3-(4,5-dimethylthiazol-2-yl)-2,5-diphenyltetrazolium bromide) assay is a colorimetric assay for assessing cell metabolic activity. Viable cells with active metabolism convert the yellow MTT into a purple formazan product. Cancer cell lines with known RTK aberrations are seeded in 96-well plates and treated with a range of **Modzatinib** concentrations for a specified period (e.g., 72 hours). After incubation, MTT reagent is added, followed by a solubilizing agent. The absorbance of the formazan product is then measured using a microplate reader. The GI50 (concentration for 50% growth inhibition) can be calculated from the dose-response curve.

- Western Blotting for Phospho-Protein Levels: This technique is used to directly assess the inhibition of kinase phosphorylation within the cell.
 - Methodology: Cancer cells are treated with **Modzatinib** for a short period (e.g., 1-2 hours). The cells are then lysed, and the protein concentration of the lysates is determined. Equal amounts of protein are separated by SDS-PAGE and transferred to a membrane. The membrane is then probed with primary antibodies specific for the phosphorylated form of the target RTK and key downstream signaling proteins (e.g., phospho-AKT, phospho-ERK). A second set of primary antibodies for the total protein levels of these targets is used as a loading control. Following incubation with secondary antibodies conjugated to an enzyme (e.g., HRP), a chemiluminescent substrate is added, and the resulting signal is detected. A reduction in the ratio of phosphorylated to total protein indicates target engagement and inhibition by **Modzatinib**.

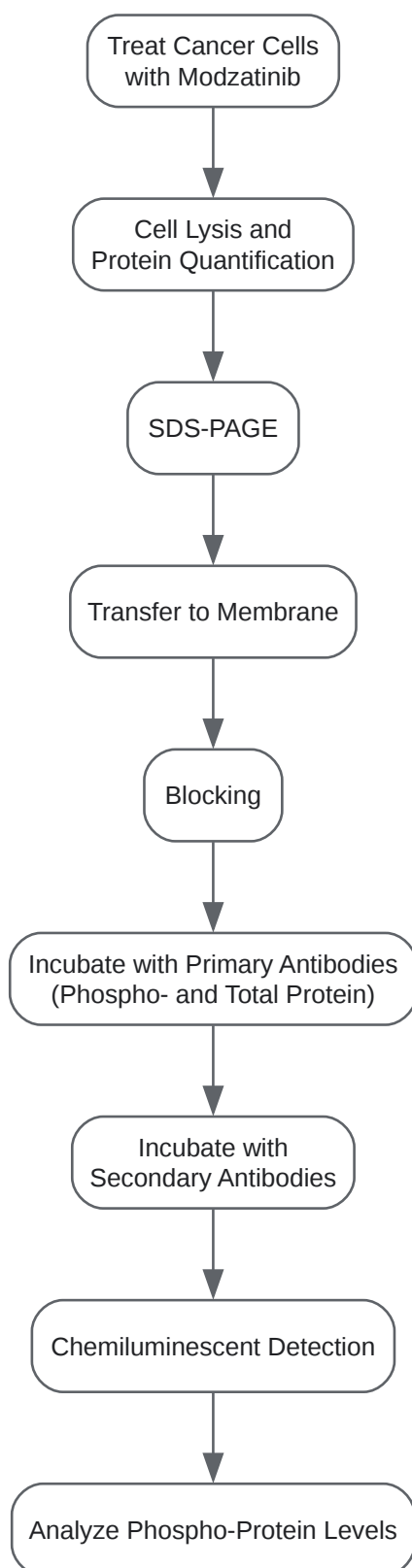

[Click to download full resolution via product page](#)

Figure 3: Standard workflow for Western blot analysis of protein phosphorylation.

Potential Mechanisms of Resistance

As with other targeted therapies, the development of resistance to **Modzatinib** is a potential clinical challenge. Understanding these mechanisms is crucial for developing strategies to overcome them.

- **Secondary Mutations in the Target Kinase:** Mutations in the ATP-binding pocket of the target RTK can prevent **Modzatinib** from binding effectively, while still allowing the kinase to remain active.
- **Activation of Bypass Signaling Pathways:** Cancer cells can develop resistance by upregulating alternative signaling pathways that bypass the inhibited RTK, thereby maintaining pro-survival and proliferative signals.
- **Drug Efflux:** Increased expression of drug efflux pumps, such as P-glycoprotein (MDR1), can actively transport **Modzatinib** out of the cancer cells, reducing its intracellular concentration and efficacy.

Conclusion

Modzatinib represents a promising targeted therapy for cancers driven by aberrant RTK signaling. A thorough understanding of its mechanism of action, facilitated by the experimental approaches outlined in this guide, is essential for its successful clinical development. Future research will need to focus on identifying the specific RTK targets of **Modzatinib**, characterizing its activity in a broad range of cancer models, and elucidating the molecular mechanisms that may contribute to resistance. As more data becomes available, a clearer picture of **Modzatinib**'s therapeutic potential and its place in the landscape of cancer treatment will emerge.

- **To cite this document:** BenchChem. [An In-depth Technical Guide to the Mechanism of Action of Modzatinib]. BenchChem, [2026]. [Online PDF]. Available at: [\[https://www.benchchem.com/product/b15610401/docs#an-in-depth-technical-guide-to-the-mechanism-of-action-of-modzatinib\]](https://www.benchchem.com/product/b15610401/docs#an-in-depth-technical-guide-to-the-mechanism-of-action-of-modzatinib)

Disclaimer & Data Validity:

The information provided in this document is for Research Use Only (RUO) and is strictly not intended for diagnostic or therapeutic procedures. While BenchChem strives to provide accurate protocols, we make no warranties, express or implied, regarding the fitness of this product for every specific experimental setup.

Technical Support: The protocols provided are for reference purposes. Unsure if this reagent suits your experiment?

Need Industrial/Bulk Grade? [Request Custom Synthesis Quote](#)

BenchChem

Our mission is to be the trusted global source of essential and advanced chemicals, empowering scientists and researchers to drive progress in science and industry.

Contact

Address: 3281 E Guasti Rd
Ontario, CA 91761, United States
Phone: (601) 213-4426
Email: info@benchchem.com

[Contact our Ph.D. Support Team for a compatibility check](#)