

Troubleshooting poor cell adhesion on G4RGDSP surfaces

Author: BenchChem Technical Support Team. **Date:** April 2026

Compound of Interest

Compound Name: *G4RGDSP, integrin-binding peptide*
Cat. No.: *B15609231*

[Get Quote](#)

Technical Support Center: G4RGDSP Surfaces

Welcome to the technical support center for G4RGDSP-coated surfaces. This resource is designed for researchers, scientists, and drug development professionals to troubleshoot and optimize cell adhesion in their experiments. Here you will find troubleshooting guides in a question-and-answer format, detailed experimental protocols, and supporting data to ensure the successful use of G4RGDSP surfaces.

Frequently Asked Questions (FAQs) & Troubleshooting

Poor cell adhesion to G4RGDSP-coated surfaces can arise from a variety of factors, from the coating procedure itself to the specific characteristics of the cells being used. This section addresses common issues and provides actionable solutions.

Q1: Why are my cells showing low or no attachment to the G4RGDSP-coated surface?

Low cell attachment is a frequent issue and can be attributed to several factors:

- **Improper Coating Procedure:** The effectiveness of the G4RGDSP coating is critical for cell adhesion. Inefficient passive adsorption can result from incorrect peptide concentration, insufficient incubation time, or the use of an inappropriate coating buffer. For initial troubleshooting, it's recommended to perform assays in serum-free media.[1]
- **Cell Type and Health:** Not all cell types will adhere equally well to an RGD motif. Cell attachment is mediated by integrin receptors, and the expression levels of relevant integrins (like $\alpha\beta3$ and $\alpha5\beta1$) vary significantly between cell types. It is crucial to confirm that your cell line expresses the appropriate integrins for RGD binding. Additionally, ensure that cells are healthy, in the logarithmic growth phase, and have not been over-trypsinized during harvesting, as this can damage cell surface receptors.
- **Presence of Serum Proteins:** When performing attachment assays in the presence of serum, other extracellular matrix (ECM) proteins like fibronectin and vitronectin can compete with the G4RGDSP peptide for binding to both the surface and cell receptors.[1] This competition can lead to lower than expected attachment to the peptide itself.
- **Divalent Cations:** Integrin-mediated binding is dependent on the presence of divalent cations such as Ca^{2+} and Mg^{2+} . Ensure your cell attachment buffer or media contains these ions at appropriate physiological concentrations.

Q2: My cell attachment is patchy and uneven across the G4RGDSP-coated surface. What is the cause?

Uneven cell attachment typically points to a problem with the coating process:

- **Incomplete Peptide Solubilization:** The G4RGDSP peptide may not have been fully dissolved before the coating step, leading to aggregates and an uneven coating solution.
- **Improper Mixing:** Ensure the peptide solution is mixed gently but thoroughly before application to the surface. Vigorous vortexing should be avoided as it can cause precipitation.
- **Insufficient Coating Volume:** Use a sufficient volume of the peptide solution to ensure the entire surface is covered evenly during incubation.

- **Surface Drying:** Allowing the surface to dry out at any point during the coating or washing steps can denature the peptide and result in an inconsistent coating.

Q3: How does the G4 spacer in G4RGDSP affect cell adhesion?

The four-glycine (G4) spacer plays a crucial role in presenting the RGD ligand to the cell's integrin receptors. Studies have shown that a minimum number of four glycine units in the spacer arm is essential for enhanced adhesion and growth of fibroblasts.[2] This flexible spacer likely provides the necessary distance and conformational freedom for the RGD motif to effectively engage with the binding pocket of the integrin receptor. Shorter spacers may not provide sufficient flexibility, leading to reduced cell attachment.

Q4: Can the G4RGDSP peptide degrade in my cell culture medium?

Yes, peptides in solution can be susceptible to degradation, which can impact the reproducibility of your experiments. The stability of the G4RGDSP peptide is influenced by factors such as pH and the presence of proteases secreted by the cells. It is recommended to prepare fresh peptide solutions for coating and to be aware of the potential for degradation over longer culture periods. For long-term storage, lyophilized peptides are more stable than those in solution.[3]

Quantitative Data Summary

The following tables summarize key quantitative data related to cell adhesion on RGD-functionalized surfaces. These values can serve as a baseline for optimizing your own experiments.

Table 1: Effect of RGD Peptide Coating Concentration on Cell Adhesion

Peptide Concentration ($\mu\text{g/mL}$)	Cell Attachment Efficiency (%)	Reference Cell Type
0.1	Low	General guidance
1.0	Moderate	General guidance
5.0	High	General guidance
10.0	High (often optimal)	General guidance
20.0	May show saturation or decrease	General guidance

Note: The optimal concentration is cell-type dependent and should be determined empirically through a titration experiment.

Table 2: Influence of RGD Peptide Density on Human Mesenchymal Stem Cell (hMSC) Adhesion

RGD Global Density (nmol/cm^2)	Attached Cell Number (relative)	Cell Spreading Area (μm^2)
1.06	Low	~1500
2.66	Medium	~2500
5.32	High	~4000

Data adapted from studies on RGD-functionalized surfaces, highlighting the trend of increased adhesion and spreading with higher ligand density.[4]

Experimental Protocols

Protocol 1: Coating Tissue Culture Plates with G4RGDSP Peptide

This protocol describes the passive adsorption of G4RGDSP peptide onto standard polystyrene tissue culture plates.

Materials:

- G4RGDSP peptide (lyophilized)
- Sterile, serum-free medium or Phosphate Buffered Saline (PBS), pH 7.4
- Sterile tissue culture plates (e.g., 96-well)
- Sterile deionized water (dH₂O)
- Laminar flow hood

Procedure:

- **Reconstitute Peptide:** In a laminar flow hood, add a precise volume of sterile, serum-free medium or PBS to the vial of lyophilized G4RGDSP peptide to achieve a desired stock concentration (e.g., 1 mg/mL).
- **Solubilize Peptide:** Gently swirl the vial to dissolve the peptide completely. Avoid vigorous vortexing. The solution may appear slightly hazy.
- **Prepare Working Solution:** Dilute the stock solution to the desired final coating concentration (a typical starting range is 1-10 µg/mL) using sterile, serum-free medium or PBS.
- **Coat Surface:** Add a sufficient volume of the G4RGDSP working solution to each well to ensure the surface is completely and evenly covered (e.g., 50 µL for a 96-well plate).
- **Incubate:** Cover the plate and incubate at room temperature or 37°C for 1-2 hours.
- **Aspirate and Wash:** Carefully aspirate the peptide solution from the wells. Wash the wells gently with sterile dH₂O, taking care not to scratch the surface.
- **Final Preparation:** The coated plates are now ready for cell seeding. They can also be stored at 2-10°C, either damp or air-dried, while maintaining sterility.

Protocol 2: Cell Adhesion Quantification Assay

This protocol outlines a method to quantify cell adhesion on G4RGDSP-coated surfaces using a crystal violet staining assay.

Materials:

- G4RGDSP-coated and control (uncoated) tissue culture plates
- Cell suspension of interest in appropriate culture medium
- PBS containing 1 mM CaCl₂ and 1 mM MgCl₂ (PBS++)
- Fixation solution: 100% methanol, pre-chilled to -20°C
- Staining solution: 0.5% w/v crystal violet in 20% ethanol
- Extraction solution: 2% SDS in dH₂O
- Microplate reader

Procedure:

- **Cell Seeding:** Trypsinize and count your cells. Adjust the cell density to the desired concentration (e.g., 3×10^5 cells/mL) in your normal culture medium. Add 100 μ L of the cell suspension to each well of the pre-coated and control plates. Include "blank" wells with medium only for background measurement.
- **Incubation:** Incubate the plate at 37°C in a CO₂ incubator for the desired attachment time (e.g., 30-60 minutes).
- **Wash Non-adherent Cells:** Gently invert the plate to remove the medium and non-adherent cells. Carefully wash the wells twice with ice-cold PBS++.
- **Fixation:** Add 300 μ L of freezer-cold 100% methanol to each well and incubate at room temperature for 10 minutes.
- **Staining:** Aspirate the methanol and add 100 μ L of crystal violet solution to each well. Gently shake the plate at room temperature for 10 minutes.
- **Wash Excess Stain:** Remove the crystal violet solution and wash the wells by immersing the plate in a beaker of dH₂O three times for 1 minute each.

- Dry: Allow the plate to air dry completely.
- Extract Stain: Add 100 μ L of 2% SDS solution to each well to solubilize the stain from the adherent cells. Incubate on an orbital shaker for 5-10 minutes.
- Quantify: Transfer 100 μ L of the extracted crystal violet solution to a new flat-bottom 96-well plate and measure the absorbance at 590 nm using a microplate reader.
- Analyze Data: Subtract the average absorbance of the blank wells from all other readings. The absorbance is directly proportional to the number of adherent cells.

Visualizations

Signaling Pathway and Experimental Workflows

The following diagrams illustrate the key molecular pathway involved in cell adhesion to G4RGDSP surfaces and provide a visual representation of the experimental workflows.

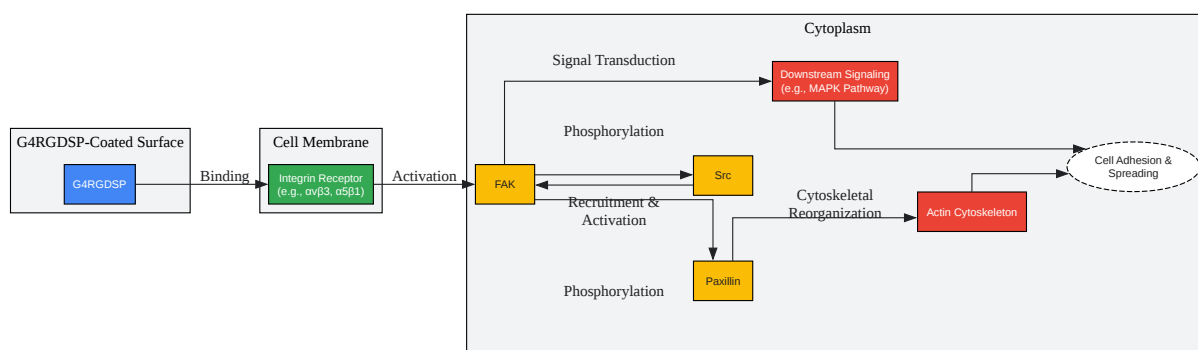

[Click to download full resolution via product page](#)

Caption: G4RGDSP-Integrin signaling pathway for cell adhesion.

Caption: Logical workflow for troubleshooting poor cell adhesion.

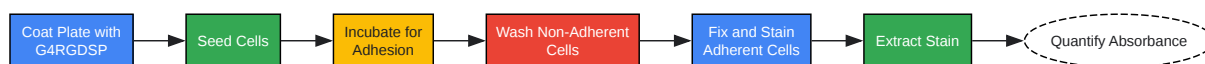

[Click to download full resolution via product page](#)

Caption: Experimental workflow for the cell adhesion quantification assay.

Need Custom Synthesis?

BenchChem offers custom synthesis for rare earth carbides and specific isotopic labeling.

Email: info@benchchem.com or [Request Quote Online](#).

References

- [1. Advantages of RGD peptides for directing cell association with biomaterials - PMC \[pmc.ncbi.nlm.nih.gov\]](#)
- [2. medchemexpress.com \[medchemexpress.com\]](#)
- [3. mdpi.com \[mdpi.com\]](#)
- [4. Development of Mesoporous Silica Nanoparticle-Based Films with Tunable Arginine–Glycine–Aspartate Peptide Global Density and Clustering Levels to Study Stem Cell Adhesion and Differentiation - PMC \[pmc.ncbi.nlm.nih.gov\]](#)
- To cite this document: BenchChem. [Troubleshooting poor cell adhesion on G4RGDSP surfaces]. BenchChem, [2026]. [Online PDF]. Available at: [\[https://www.benchchem.com/product/b15609231/docs#troubleshooting-poor-cell-adhesion-on-g4rgdsp-surfaces\]](https://www.benchchem.com/product/b15609231/docs#troubleshooting-poor-cell-adhesion-on-g4rgdsp-surfaces)

Disclaimer & Data Validity:

The information provided in this document is for Research Use Only (RUO) and is strictly not intended for diagnostic or therapeutic procedures. While BenchChem strives to provide accurate protocols, we make no warranties, express or implied, regarding the fitness of this product for every specific experimental setup.

Technical Support: The protocols provided are for reference purposes. Unsure if this reagent suits your experiment?

Need Industrial/Bulk Grade? [Request Custom Synthesis Quote](#)

BenchChem

Our mission is to be the trusted global source of essential and advanced chemicals, empowering scientists and researchers to drive progress in science and industry.

Contact

Address: 3281 E Guasti Rd
Ontario, CA 91761, United States
Phone: (601) 213-4426
Email: info@benchchem.com

[Contact our Ph.D. Support Team for a compatibility check](#)