

Technical Support Center: Understanding and Mitigating Off-Target Effects

Author: BenchChem Technical Support Team. **Date:** April 2026

Compound of Interest

Compound Name: *FKBP12 PROTAC RC32*

Cat. No.: *B15609558*

[Get Quote](#)

This technical support center provides guidance for researchers, scientists, and drug development professionals on identifying and mitigating potential off-target effects associated with two distinct molecules: the protein RGC-32 (Response Gene to Complement 32) and the cyclin-dependent kinase inhibitor SNS-032. The initial query "RC32" may have intended to refer to either of these, and thus, dedicated sections are provided for both.

Section 1: RGC-32 (Response Gene to Complement 32)

Response Gene to Complement 32 (RGC-32) is a protein implicated in a wide range of cellular processes, including cell cycle regulation, differentiation, and fibrosis.^{[1][2][3]} Its multifaceted nature means that modulating its expression or activity can lead to unintended or "off-target" consequences in experimental systems. This section addresses common concerns and troubleshooting strategies related to RGC-32 research.

Frequently Asked Questions (FAQs)

Q1: What are the primary functions of RGC-32 that could lead to off-target effects when modulated?

A1: RGC-32 is a versatile protein with several key functions that can have widespread effects on cellular physiology.[1][2] Its primary roles include:

- **Cell Cycle Regulation:** RGC-32 is known to act as a cell cycle regulator.[2] For instance, it has been identified as a p53-inducible gene that can cause G2/M arrest.[4] Modulating RGC-32 can therefore unintentionally affect cell proliferation and division in ways not directly related to the primary research question.
- **Signal Transduction:** RGC-32 is involved in multiple signaling pathways, including TGF- β signaling.[3] It can interact with Smad3 and is essential for the differentiation of Th17 cells.[3] Altering RGC-32 levels can thus have cascading effects on these interconnected pathways.
- **Inflammation and Metabolism:** RGC-32 plays a role in inflammation and has been linked to inflammatory vascular diseases.[1] It is also implicated in lipid and glucose metabolism.[2] Experimental manipulation of RGC-32 could therefore lead to unexpected inflammatory or metabolic phenotypes.

Q2: We are observing unexpected changes in cell proliferation in our RGC-32 knockdown experiment. How can we troubleshoot this?

A2: Unexpected effects on cell proliferation are a common concern due to RGC-32's role in the cell cycle.[2][4] To troubleshoot this, consider the following:

- **Confirm Knockdown Specificity:** Ensure that your knockdown strategy (e.g., siRNA, shRNA) is specific to RGC-32 and is not affecting the expression of other genes. Use at least two different non-overlapping sequences targeting RGC-32 to see if the phenotype is consistent.
- **Rescue Experiment:** Perform a rescue experiment by re-introducing an expression vector for RGC-32 that is resistant to your knockdown construct. If the proliferation phenotype is reversed, it confirms that the effect is specifically due to the loss of RGC-32.
- **Cell Cycle Analysis:** Perform flow cytometry-based cell cycle analysis to determine at which phase of the cell cycle the cells are being affected. This can provide clues as to the specific pathway being perturbed.
- **Examine Related Pathways:** Analyze the expression and activation of key cell cycle regulators downstream of RGC-32, such as proteins involved in the G2/M checkpoint.[4]

Troubleshooting Guide

Observed Issue	Potential Cause	Recommended Action
Unexpected inflammatory response	RGC-32 is involved in endothelial cell activation and immune cell function.[1][5]	- Measure the expression of pro-inflammatory cytokines (e.g., IL-6) and anti-inflammatory cytokines (e.g., TGF- β).[2]- Assess the activation status of inflammatory signaling pathways, such as NF- κ B.[5]
Altered cell differentiation	RGC-32 is crucial for the differentiation of certain cell types, like Th17 cells and vascular smooth muscle cells.[2][3]	- Use multiple differentiation markers to confirm the cell phenotype.- Investigate the activity of the TGF- β signaling pathway, a key pathway in which RGC-32 participates.[3]
Inconsistent results across different cell lines	The function of RGC-32 can be highly context-dependent, varying with the cellular environment and genetic background.	- Characterize the basal expression level of RGC-32 in your cell lines.- Consider the presence of interacting partners and the status of relevant signaling pathways in each cell line.

Experimental Protocols

Protocol 1: Validating Specificity of RGC-32 Modulation

- Design: Use at least two independent siRNAs or shRNAs targeting different regions of the RGC-32 mRNA. Include a non-targeting control.
- Transfection/Transduction: Deliver the knockdown constructs into your cells of interest.
- Verification of Knockdown: At 48-72 hours post-transfection, harvest cells and perform qRT-PCR and Western blotting to confirm the specific reduction of RGC-32 mRNA and protein

levels, respectively.

- **Phenotypic Analysis:** Assess the desired on-target phenotype and any potential off-target phenotypes (e.g., changes in proliferation, expression of inflammatory markers).
- **Rescue Experiment (Optional but Recommended):** Co-transfect the knockdown construct with a plasmid expressing a codon-optimized, siRNA-resistant version of RGC-32. Assess if the off-target phenotype is reversed.

Signaling Pathway Diagram

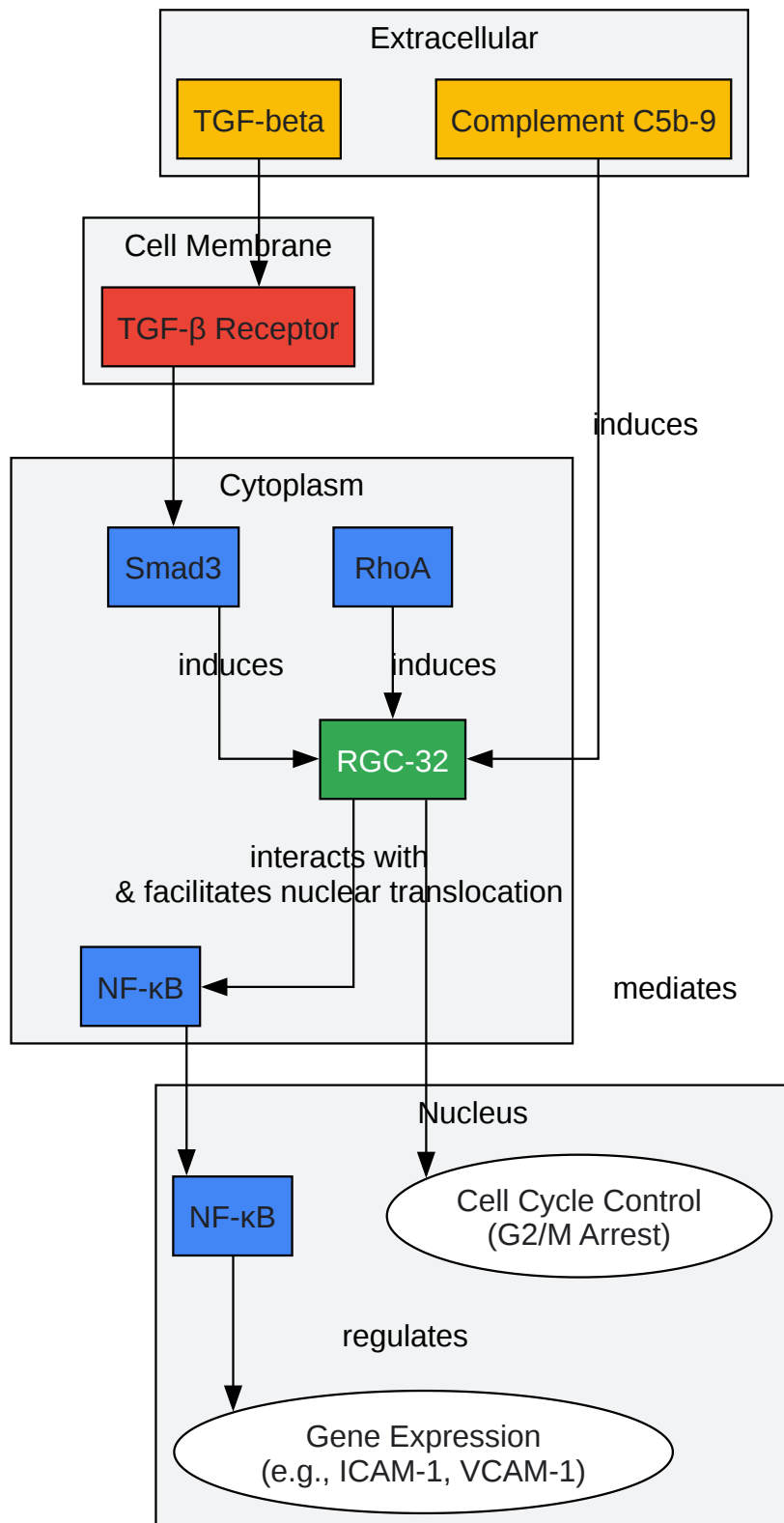

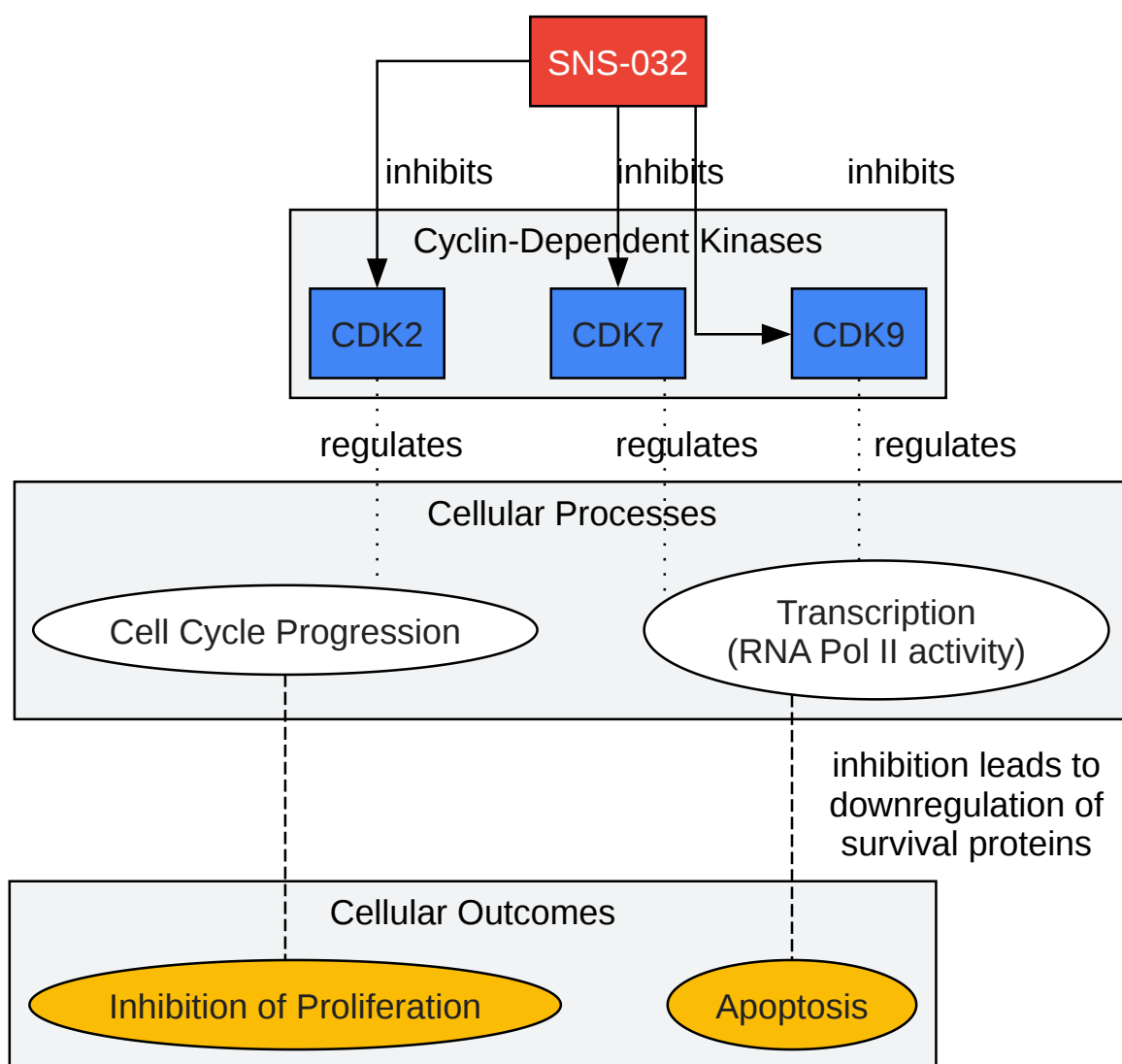

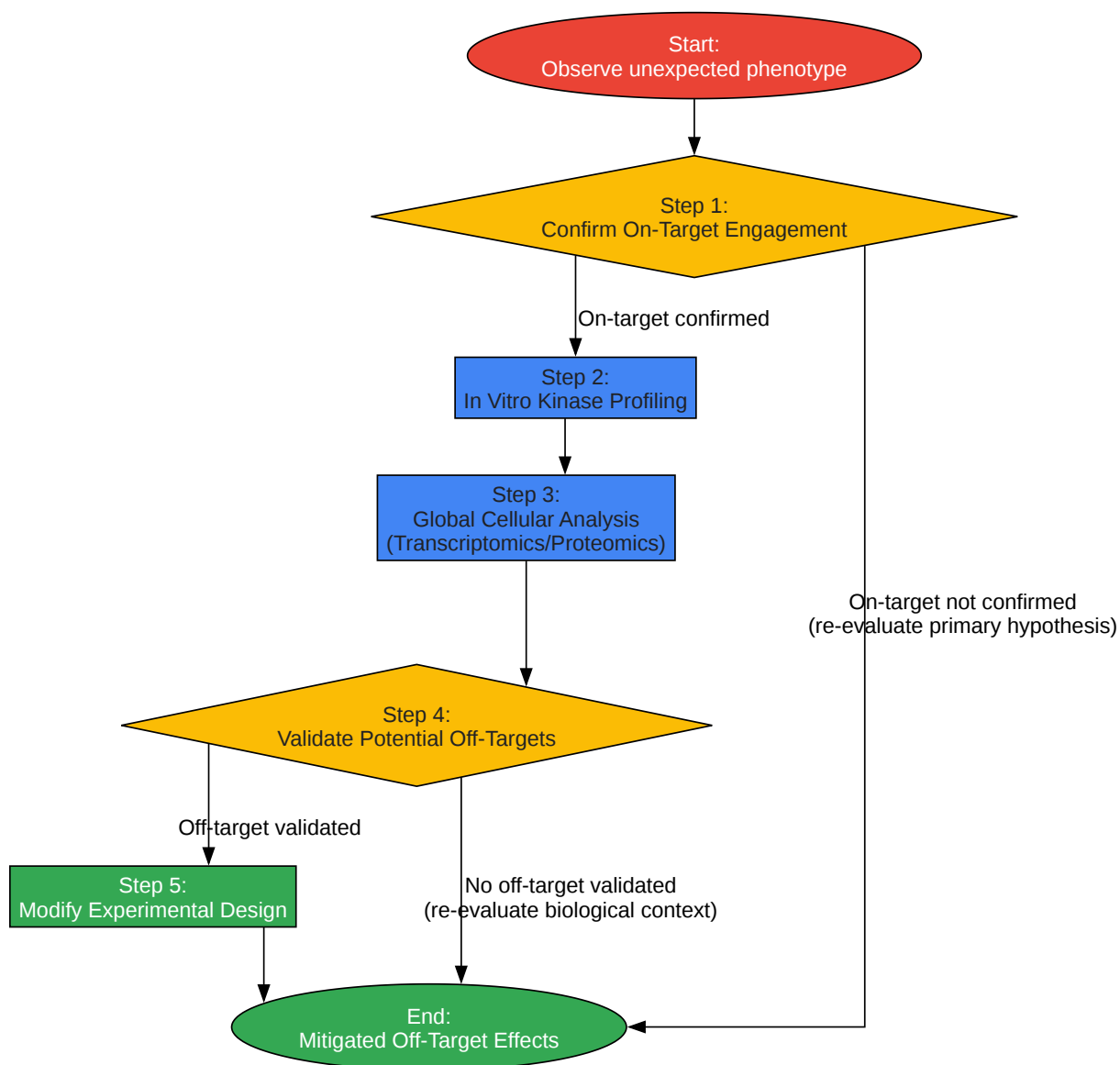

[Click to download full resolution via product page](#)

Need Custom Synthesis?

BenchChem offers custom synthesis for rare earth carbides and specific isotopic labeling.

Email: info@benchchem.com or [Request Quote Online](#).

References

- [1. Response Gene to Complement 32 in Vascular Diseases - PubMed \[pubmed.ncbi.nlm.nih.gov\]](#)
- [2. New insights into the roles of RGC-32 - PMC \[pmc.ncbi.nlm.nih.gov\]](#)
- [3. RGC-32 and diseases: the first 20 years - PubMed \[pubmed.ncbi.nlm.nih.gov\]](#)
- [4. RGC32, a novel p53-inducible gene, is located on centrosomes during mitosis and results in G2/M arrest - PubMed \[pubmed.ncbi.nlm.nih.gov\]](#)
- [5. ahajournals.org \[ahajournals.org\]](#)
- To cite this document: BenchChem. [Technical Support Center: Understanding and Mitigating Off-Target Effects]. BenchChem, [2026]. [Online PDF]. Available at: [\[https://www.benchchem.com/product/b15609558/docs#technical-support-center-understanding-and-mitigating-off-target-effects\]](https://www.benchchem.com/product/b15609558/docs#technical-support-center-understanding-and-mitigating-off-target-effects)

Disclaimer & Data Validity:

The information provided in this document is for Research Use Only (RUO) and is strictly not intended for diagnostic or therapeutic procedures. While BenchChem strives to provide accurate protocols, we make no warranties, express or implied, regarding the fitness of this product for every specific experimental setup.

Technical Support: The protocols provided are for reference purposes. Unsure if this reagent suits your experiment?

Need Industrial/Bulk Grade? [Request Custom Synthesis Quote](#)

BenchChem

Our mission is to be the trusted global source of essential and advanced chemicals, empowering scientists and researchers to drive progress in science and industry.

Contact

Address: 3281 E Guasti Rd

Ontario, CA 91761, United States

Phone: (601) 213-4426

Email: info@benchchem.com

[Contact our Ph.D. Support Team for a compatibility check](#)