

Technical Support Center: Matrix Effects in LC-MS/MS Analysis

Author: BenchChem Technical Support Team. **Date:** April 2026

Compound of Interest

Compound Name: *Des-ethyl-carafiban*

CAS No.: 170565-45-4

Cat. No.: B15609023

[Get Quote](#)

This technical support center provides troubleshooting guides and Frequently Asked Questions (FAQs) to assist researchers, scientists, and drug development professionals in addressing matrix effects encountered during the Liquid Chromatography-Tandem Mass Spectrometry (LC-MS/MS) analysis of small molecules like **Des-ethyl-carafiban**.

Frequently Asked Questions (FAQs)

Q1: What are matrix effects and how do they impact the LC-MS/MS analysis of **Des-ethyl-carafiban**?

A: Matrix effects are the alteration of ionization efficiency for a target analyte, such as **Des-ethyl-carafiban**, by the presence of co-eluting compounds from the sample matrix.^{[1][2]} In the analysis of **Des-ethyl-carafiban** from biological matrices like plasma, urine, or tissue homogenates, these effects can lead to either ion suppression (decreased signal) or ion enhancement (increased signal).^{[2][3]} This interference can significantly compromise the accuracy, precision, and sensitivity of the analytical method, leading to unreliable quantification.^{[4][5]}

Q2: What are the most common sources of matrix effects in bioanalysis?

A: The primary sources of matrix effects in biofluids are endogenous components that are co-extracted and co-eluted with the analyte of interest.[2][6] For plasma or serum samples, phospholipids are a major contributor to matrix-induced ionization suppression.[7] Other sources include salts, proteins, and metabolites.[2][8] In some cases, exogenous compounds such as anticoagulants or dosing vehicles can also contribute to matrix effects.[6]

Q3: How can I detect the presence of matrix effects in my assay?

A: There are two primary methods for assessing matrix effects:

- **Qualitative Assessment (Post-Column Infusion):** This technique involves infusing a constant flow of the analyte solution into the mass spectrometer while a blank, extracted matrix sample is injected into the LC system.[5][9] Any deviation in the baseline signal at the retention time of the analyte indicates the presence of ion suppression or enhancement.[5]
- **Quantitative Assessment (Post-Extraction Spike):** This method provides a quantitative measure of the matrix effect.[3][7] It involves comparing the peak area of an analyte spiked into an extracted blank matrix sample with the peak area of the analyte in a neat solution (e.g., mobile phase). The ratio of these two peak areas indicates the extent of ion suppression or enhancement.[10]

Q4: What are the primary strategies to mitigate or eliminate matrix effects?

A: Several strategies can be employed to minimize the impact of matrix effects:

- **Sample Preparation:** Implementing a more rigorous sample clean-up procedure is one of the most effective ways to reduce matrix effects.[3] Techniques like Solid-Phase Extraction (SPE) and Liquid-Liquid Extraction (LLE) are generally more effective at removing interfering components than a simple protein precipitation.[3]
- **Chromatographic Separation:** Optimizing the LC method to separate the analyte from co-eluting matrix components can significantly reduce interference.[4][11] This can be achieved by adjusting the column chemistry, mobile phase composition, and gradient profile.[4][9]

- **Use of Internal Standards:** The use of a stable isotope-labeled internal standard (SIL-IS) is the most reliable way to compensate for matrix effects.[1][9] A SIL-IS co-elutes with the analyte and experiences the same degree of ion suppression or enhancement, thus providing a consistent analyte-to-internal standard ratio for accurate quantification.[3][9]
- **Matrix-Matched Calibrators:** Preparing calibration standards in the same matrix as the samples can help to compensate for matrix effects by ensuring that both the calibrators and the samples are affected similarly.[3]
- **Sample Dilution:** Diluting the sample can reduce the concentration of interfering matrix components, but this approach is only feasible if the analyte concentration is high enough to remain above the limit of quantification after dilution.[4]

Troubleshooting Guides

Problem: Poor reproducibility and accuracy in Des-ethyl-carafiban quantification.

This is a common symptom of unaddressed matrix effects. The following workflow can help identify and resolve the issue.

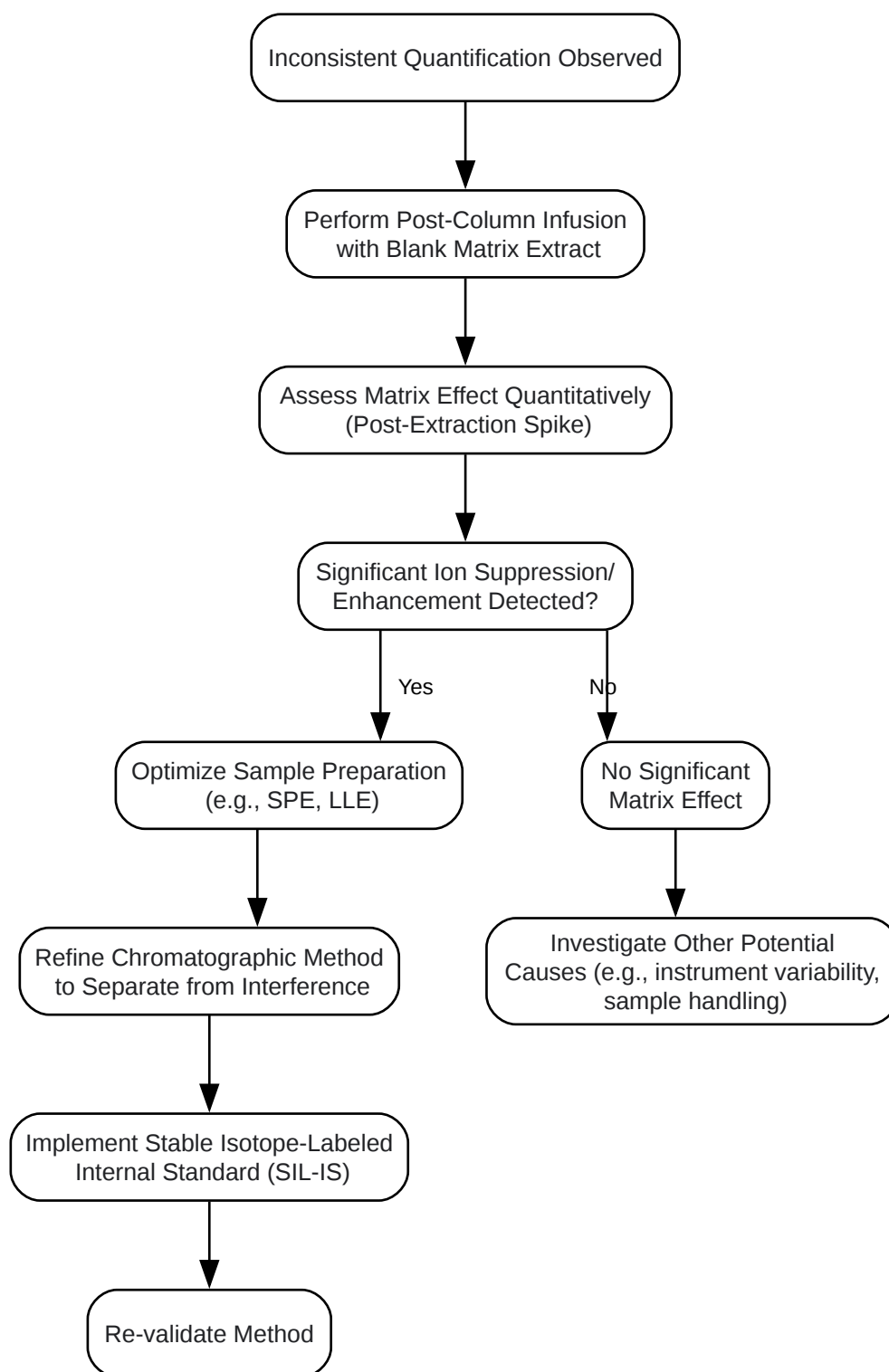

[Click to download full resolution via product page](#)

Caption: Troubleshooting workflow for inconsistent quantification.

Problem: Significant ion suppression observed for Des-ethyl-carafiban.

When a particular analyte shows a consistent drop in signal, the following decision tree can guide the mitigation strategy.

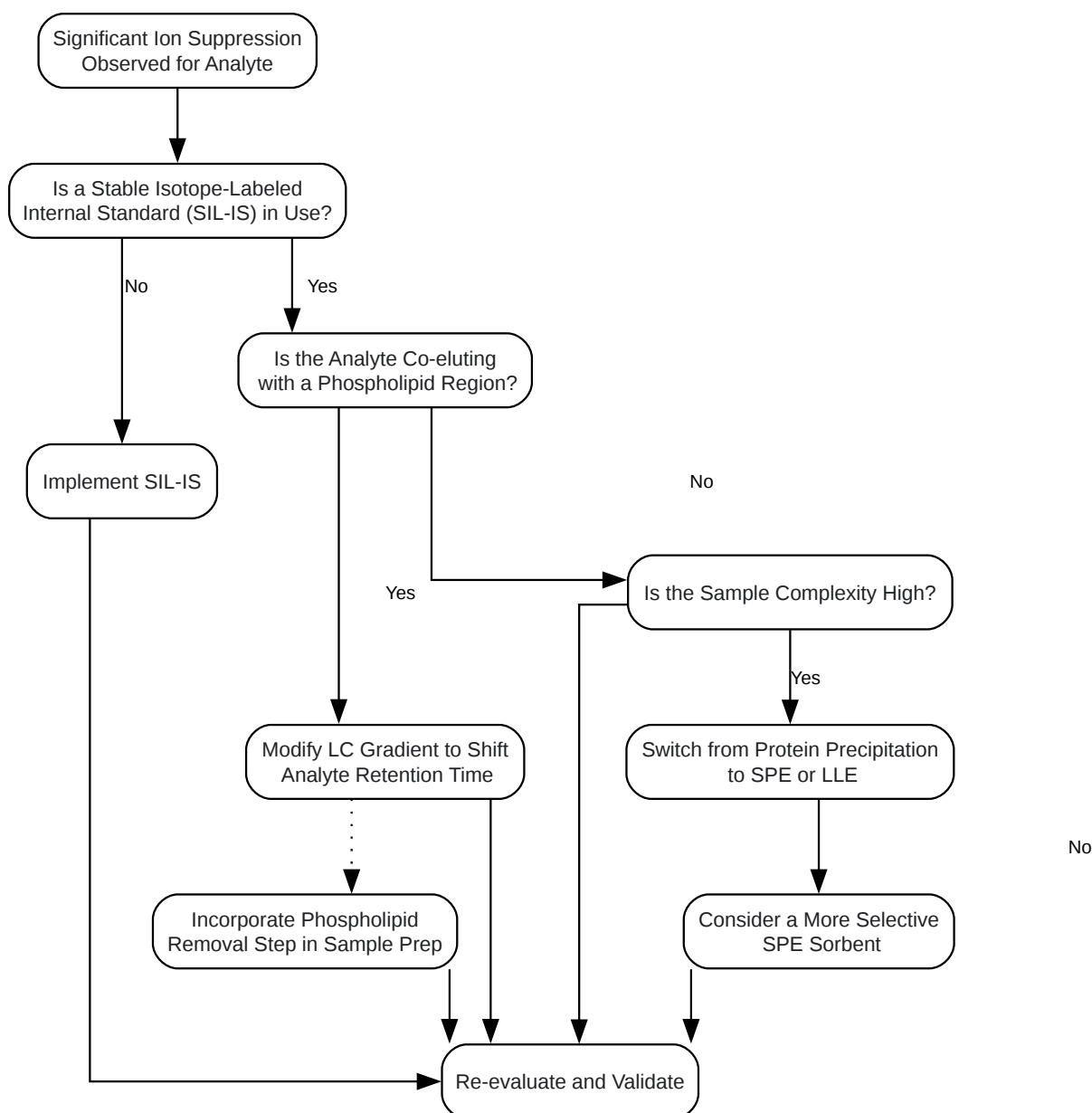

[Click to download full resolution via product page](#)

Caption: Decision tree for mitigating ion suppression.

Quantitative Data Summary

The choice of sample preparation is critical in minimizing matrix effects. The following table summarizes general trends for matrix effects with various sample preparation techniques in different biological matrices. A value of 100% indicates no matrix effect, <100% indicates ion suppression, and >100% indicates ion enhancement.

Biological Matrix	Sample Preparation Method	Typical Matrix Effect Range (%)	Key Considerations
Plasma/Serum	Protein Precipitation (PPT)	30 - 110	Prone to significant ion suppression due to residual phospholipids.
Liquid-Liquid Extraction (LLE)	70 - 120	Generally cleaner than PPT, but optimization of extraction solvent is crucial. [3]	
Solid-Phase Extraction (SPE)	85 - 115	Offers the most effective removal of interferences, but requires method development. [3]	
Urine	Dilute-and-Inject	50 - 130	Simple, but susceptible to high variability in matrix effects due to diet and hydration. [4] [12]
SPE	90 - 110	Highly recommended for urine to remove salts and other polar interferences. [12]	
Oral Fluid	PPT with Acetonitrile	60 - 115	Can provide sufficient clean-up for this less complex matrix. [13]

Note: A direct comparison is challenging due to variations in experimental conditions across different studies. The provided data illustrates general trends.

Experimental Protocols

Protocol 1: Qualitative Assessment of Matrix Effects by Post-Column Infusion

Objective: To identify regions in the chromatogram where co-eluting matrix components cause ion suppression or enhancement.

Methodology:

- Preparation of Infusion Solution: Prepare a solution of **Des-ethyl-carafiban** in the mobile phase at a concentration that gives a stable and moderate signal (e.g., 100 ng/mL).
- System Setup:
 - Infuse the analyte solution into the MS ion source at a constant flow rate (e.g., 10 μ L/min) using a syringe pump.
 - Connect the LC outlet to the ion source via a T-connector, allowing the column effluent to mix with the infused solution before entering the MS.
- Analysis:
 - Begin infusing the analyte solution and allow the MS signal to stabilize.
 - Inject a blank matrix sample that has been subjected to the sample extraction procedure.
 - Monitor the analyte's signal throughout the chromatographic run.
- Interpretation:
 - A stable baseline indicates no matrix effects.
 - A dip in the baseline indicates ion suppression at that retention time.
 - A rise in the baseline indicates ion enhancement at that retention time.

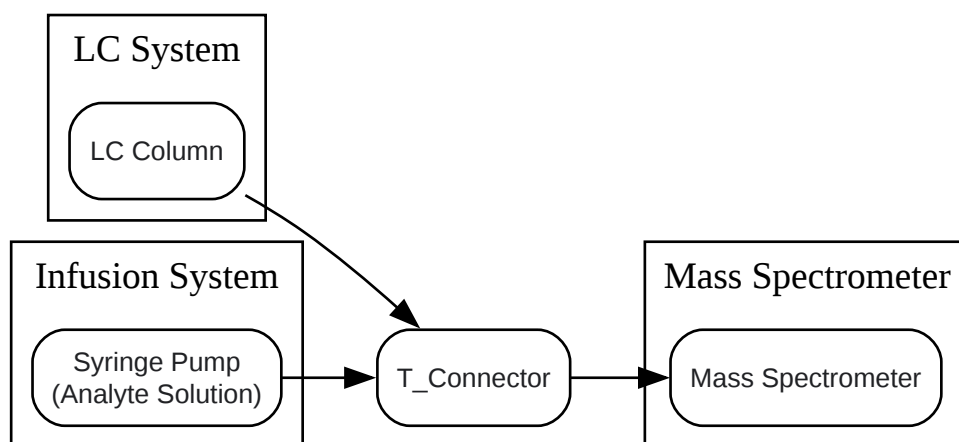

[Click to download full resolution via product page](#)

Need Custom Synthesis?

BenchChem offers custom synthesis for rare earth carbides and specific isotopic labeling.

Email: info@benchchem.com or [Request Quote Online](#).

References

- 1. chromatographyonline.com [chromatographyonline.com]
- 2. tandfonline.com [tandfonline.com]
- 3. longdom.org [longdom.org]
- 4. Compensate for or Minimize Matrix Effects? Strategies for Overcoming Matrix Effects in Liquid Chromatography-Mass Spectrometry Technique: A Tutorial Review - PMC [pmc.ncbi.nlm.nih.gov]
- 5. TROUBLE SHOOTING DURING BIOANALYTICAL ESTIMATION OF DRUG AND METABOLITES USING LC-MS/MS: A REVIEW - PMC [pmc.ncbi.nlm.nih.gov]
- 6. Assessment of matrix effect in quantitative LC-MS bioanalysis - PMC [pmc.ncbi.nlm.nih.gov]
- 7. chromatographyonline.com [chromatographyonline.com]
- 8. m.youtube.com [m.youtube.com]
- 9. myadlm.org [myadlm.org]

- [10. Biological Matrix Effects in Quantitative Tandem Mass Spectrometry-Based Analytical Methods: Advancing Biomonitoring - PMC \[pmc.ncbi.nlm.nih.gov\]](#)
- [11. benchchem.com \[benchchem.com\]](#)
- [12. Matrix effect in bio-analysis of illicit drugs with LC-MS/MS: influence of ionization type, sample preparation, and biofluid - PubMed \[pubmed.ncbi.nlm.nih.gov\]](#)
- [13. pubs.acs.org \[pubs.acs.org\]](#)
- To cite this document: BenchChem. [Technical Support Center: Matrix Effects in LC-MS/MS Analysis]. BenchChem, [2026]. [Online PDF]. Available at: [\[https://www.benchchem.com/product/b15609023/docs#technical-support-center-matrix-effects-in-lc-ms-ms-analysis\]](https://www.benchchem.com/product/b15609023/docs#technical-support-center-matrix-effects-in-lc-ms-ms-analysis)

Disclaimer & Data Validity:

The information provided in this document is for Research Use Only (RUO) and is strictly not intended for diagnostic or therapeutic procedures. While BenchChem strives to provide accurate protocols, we make no warranties, express or implied, regarding the fitness of this product for every specific experimental setup.

Technical Support: The protocols provided are for reference purposes. Unsure if this reagent suits your experiment?

Need Industrial/Bulk Grade? [Request Custom Synthesis Quote](#)

BenchChem

Our mission is to be the trusted global source of essential and advanced chemicals, empowering scientists and researchers to drive progress in science and industry.

Contact

Address: 3281 E Guasti Rd
Ontario, CA 91761, United States
Phone: (601) 213-4426
Email: info@benchchem.com

Contact our Ph.D. Support Team for a compatibility check