

Technical Support Center: G4RGDSP Peptide Bioactivity Assessment

Author: BenchChem Technical Support Team. **Date:** April 2026

Compound of Interest

Compound Name: *G4RGDSP, integrin-binding peptide*

Cat. No.: *B15609231*

[Get Quote](#)

This guide provides researchers, scientists, and drug development professionals with detailed protocols, troubleshooting advice, and frequently asked questions for assessing the bioactivity of synthesized G4RGDSP peptide.

Frequently Asked Questions (FAQs) & Troubleshooting Guide

This section addresses common issues encountered during experiments with G4RGDSP-coated surfaces and related bioactivity assays.

Q1: Why are my cells not attaching, or attaching poorly, to the G4RGDSP-coated surface?

A1: Low or no cell attachment is a frequent issue that can arise from several factors concerning the peptide, coating procedure, cells, or assay conditions.

- **Peptide Integrity and Purity:** Ensure the synthesized G4RGDSP peptide has the correct sequence and a high purity level (typically >95%). Impurities or degradation can significantly hinder bioactivity. Confirm the peptide's identity via mass spectrometry and purity by HPLC.

- **Coating Procedure:** Inefficient passive adsorption can result from incorrect peptide concentration, insufficient incubation time, or an inappropriate coating buffer (PBS is standard). The surface material can also influence coating efficiency.
- **Cell Type and Health:** Cell attachment is mediated by integrin receptors, and the expression levels of relevant integrins (like $\alpha\beta3$ and $\alpha5\beta1$) vary significantly between cell types. Confirm that your cell line expresses the appropriate integrins for RGD binding. Additionally, ensure cells are healthy, in the logarithmic growth phase, and were not over-trypsinized during harvesting, as this can damage surface receptors.
- **Presence of Serum Proteins:** If performing the attachment assay in the presence of serum, other extracellular matrix (ECM) proteins like fibronectin and vitronectin will compete with the G4RGDSP peptide for both surface and cell receptor binding. For initial troubleshooting, it is recommended to perform the assay in serum-free media.
- **Divalent Cations:** Integrin-mediated binding is dependent on the presence of divalent cations such as Ca^{2+} and Mg^{2+} . Ensure your cell attachment buffer or media contains these ions at appropriate physiological concentrations.

Q2: My cell attachment is patchy and uneven across the well or surface. What is the likely cause?

A2: Uneven attachment typically points to a problem with the coating process.

- **Incomplete Solubilization:** The peptide may not have been fully dissolved before the coating step, leading to aggregates and an uneven coating solution. Ensure the peptide is completely solubilized, using sonication if necessary.
- **Improper Mixing:** Gently but thoroughly mix the peptide solution before adding it to the surface.
- **Insufficient Coating Volume:** Use a sufficient volume of the peptide solution to ensure the entire surface is covered evenly during incubation.
- **Drying Out:** Do not allow the wells to dry out at any stage of the coating or cell seeding process, as this can denature the peptide and cause uneven cell distribution.

Q3: How can I confirm that the observed cell adhesion is specifically mediated by the RGD sequence?

A3: To verify the specificity of the interaction, you should include negative controls in your experiment.

- **Scrambled Peptide Control:** Use a peptide with the same amino acid composition but a scrambled sequence, such as G4RDGSP. Cells should not adhere to surfaces coated with the scrambled peptide.
- **Competitive Inhibition:** Pre-incubate the cells with soluble G4RGDSP peptide before seeding them onto the G4RGDSP-coated surface. The soluble peptide will compete for integrin binding and should inhibit cell attachment to the surface in a dose-dependent manner.

Q4: My results from the competitive inhibition assay are not showing a clear dose-response curve. What could be wrong?

A4: This can be due to several factors related to the assay setup.

- **Peptide Concentration Range:** The concentration range of your competing peptide may be too high or too low. A typical starting point for IC₅₀ determination is a wide range from nanomolar to high micromolar concentrations.
- **Incubation Times:** Ensure sufficient pre-incubation time for the soluble competitor peptide to bind to the cell surface integrins before adding them to the coated plate.
- **Washing Steps:** Insufficient or overly aggressive washing steps can lead to high background or loss of specifically bound cells, respectively. Optimize your washing procedure.

Quantitative Data Summary

While specific EC₅₀ or IC₅₀ values for the G4RGDSP peptide are not extensively documented in publicly available literature, the following table provides typical bioactivity values for related linear and cyclic RGD peptides to serve as a benchmark for your experiments. The G4 (Gly-Gly-Gly-Gly) linker in G4RGDSP is designed to provide flexibility and enhance the presentation of the RGDSP motif to cell surface integrins. Studies have shown that RGDSP-functionalized

hydrogels significantly improve cell viability and accelerate the formation of epithelial spheroids[1].

Peptide	Assay Type	Cell Line	Bioactivity (IC50)	Reference
GRGDS	Integrin $\alpha\beta3$ Binding	U87MG	~5 μ M	[2]
cyclo(RGDfK)	Integrin $\alpha\beta3$ Binding	U87MG	79.2 \pm 4.2 nM	[3]
E[c(RGDyK)] ₂	Integrin $\alpha\beta3$ Binding	U87MG	144 \pm 6.5 nM	[3]
DOTA-P-RGD	Integrin $\alpha\beta3$ Binding	U87MG	44.3 \pm 3.5 nM	

IC50 (Half-maximal inhibitory concentration) values represent the concentration of a peptide required to inhibit 50% of the specific binding of a radiolabeled ligand.

Key Experimental Protocols

Protocol 1: Cell Adhesion Assay

This protocol describes a basic method to quantify cell attachment to G4RGDSP-coated surfaces.

Materials:

- G4RGDSP and scrambled control (G4RDGSP) peptides
- 96-well tissue culture plates
- Phosphate-Buffered Saline (PBS)
- Cell suspension of interest (e.g., fibroblasts, endothelial cells)
- Serum-free cell culture medium

- Blocking solution: 1% Bovine Serum Albumin (BSA) in PBS
- Fixing solution: 4% Paraformaldehyde (PFA) in PBS
- Staining solution: 0.5% (w/v) Crystal Violet in 20% methanol
- Solubilization buffer: 10% acetic acid
- Plate reader

Procedure:

- Peptide Solubilization: Dissolve the G4RGDSP and control peptides in sterile PBS to a stock concentration of 1 mg/mL.
- Plate Coating: Prepare working solutions of the peptide in PBS at various concentrations (e.g., 0.1, 1, 5, 10, 20 $\mu\text{g}/\text{mL}$). Add 50 μL of each working solution to the wells of a 96-well plate. Include wells with PBS only as a negative control.
- Incubation: Incubate the plate at 37°C for 2 hours or overnight at 4°C.
- Washing and Blocking: Aspirate the peptide solution and wash the wells twice with PBS. Add 150 μL of 1% BSA blocking solution to each well and incubate for 1 hour at 37°C to block non-specific cell adhesion.
- Cell Seeding: Wash the wells twice with PBS. Trypsinize and resuspend cells in serum-free medium. Seed 1-5 x 10⁴ cells per well in 100 μL of medium.
- Cell Attachment: Incubate the plate for 60-120 minutes at 37°C in a CO₂ incubator to allow for cell attachment.
- Removal of Non-adherent Cells: Gently wash the wells twice with PBS to remove non-adherent cells.
- Fixation and Staining: Fix the adherent cells with 100 μL of 4% PFA for 15 minutes. Wash with water and stain with 100 μL of 0.5% crystal violet solution for 20 minutes.

- Quantification: Wash the wells thoroughly with water to remove excess stain and allow them to air dry. Solubilize the stain by adding 100 μ L of 10% acetic acid to each well. Measure the absorbance at 570 nm using a plate reader. The absorbance is proportional to the number of adherent cells.

Protocol 2: Competitive Inhibition ELISA

This protocol is used to determine the IC₅₀ value of the G4RGDSP peptide by measuring its ability to compete with an immobilized ligand for binding to a specific integrin receptor.

Materials:

- Purified integrin receptor (e.g., α v β 3)
- Extracellular matrix protein (e.g., Vitronectin or Fibronectin)
- G4RGDSP peptide
- 96-well ELISA plates
- Coating Buffer (e.g., carbonate-bicarbonate buffer, pH 9.6)
- Wash Buffer (PBS with 0.05% Tween-20)
- Blocking Buffer (1% BSA in PBS)
- Primary antibody against the integrin
- HRP-conjugated secondary antibody
- TMB substrate and Stop Solution
- Plate reader

Procedure:

- Plate Coating: Coat the wells of a 96-well plate with 100 μ L of vitronectin (1-10 μ g/mL in coating buffer) overnight at 4°C.

- Blocking: Wash the plate three times with Wash Buffer. Block the wells with 200 μ L of Blocking Buffer for 2 hours at room temperature.
- Competitive Reaction:
 - Prepare serial dilutions of the G4RGDSP peptide (the competitor) in a separate plate or tubes.
 - In each well of the serial dilution plate, mix the G4RGDSP dilution with a constant concentration of the purified integrin receptor.
 - Incubate this mixture for 1 hour at 37°C to allow the peptide to bind to the receptor.
- Binding to Coated Plate: Wash the vitronectin-coated plate three times. Transfer 100 μ L of the peptide/integrin mixture to each well of the coated plate. Incubate for 2 hours at 37°C.
- Detection:
 - Wash the plate three times.
 - Add 100 μ L of the primary antibody (diluted in Blocking Buffer) to each well and incubate for 1 hour.
 - Wash the plate three times.
 - Add 100 μ L of the HRP-conjugated secondary antibody and incubate for 1 hour.
- Development: Wash the plate five times. Add 100 μ L of TMB substrate and incubate in the dark until a blue color develops (15-30 minutes).
- Reading: Stop the reaction by adding 50 μ L of Stop Solution. Read the absorbance at 450 nm. A lower absorbance indicates greater inhibition by the G4RGDSP peptide. The IC50 value can be calculated from the resulting dose-response curve.

Visualized Workflows and Pathways

Experimental Workflow for Bioactivity Assessment

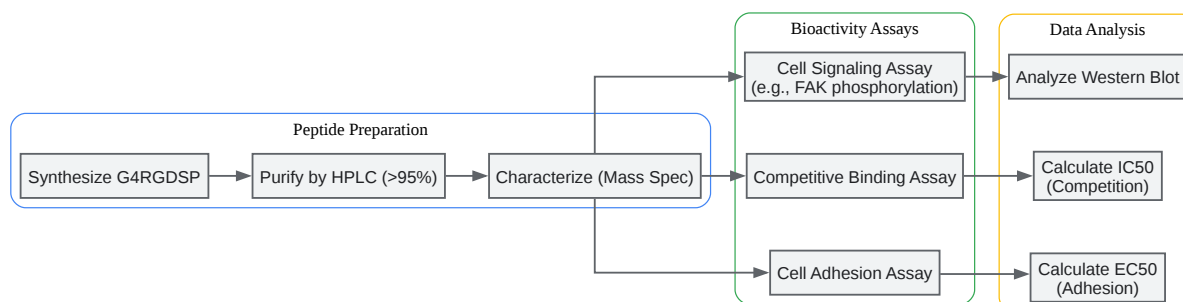

[Click to download full resolution via product page](#)

Caption: General workflow for assessing G4RGDSP peptide bioactivity.

Troubleshooting Logic for Low Cell Adhesion

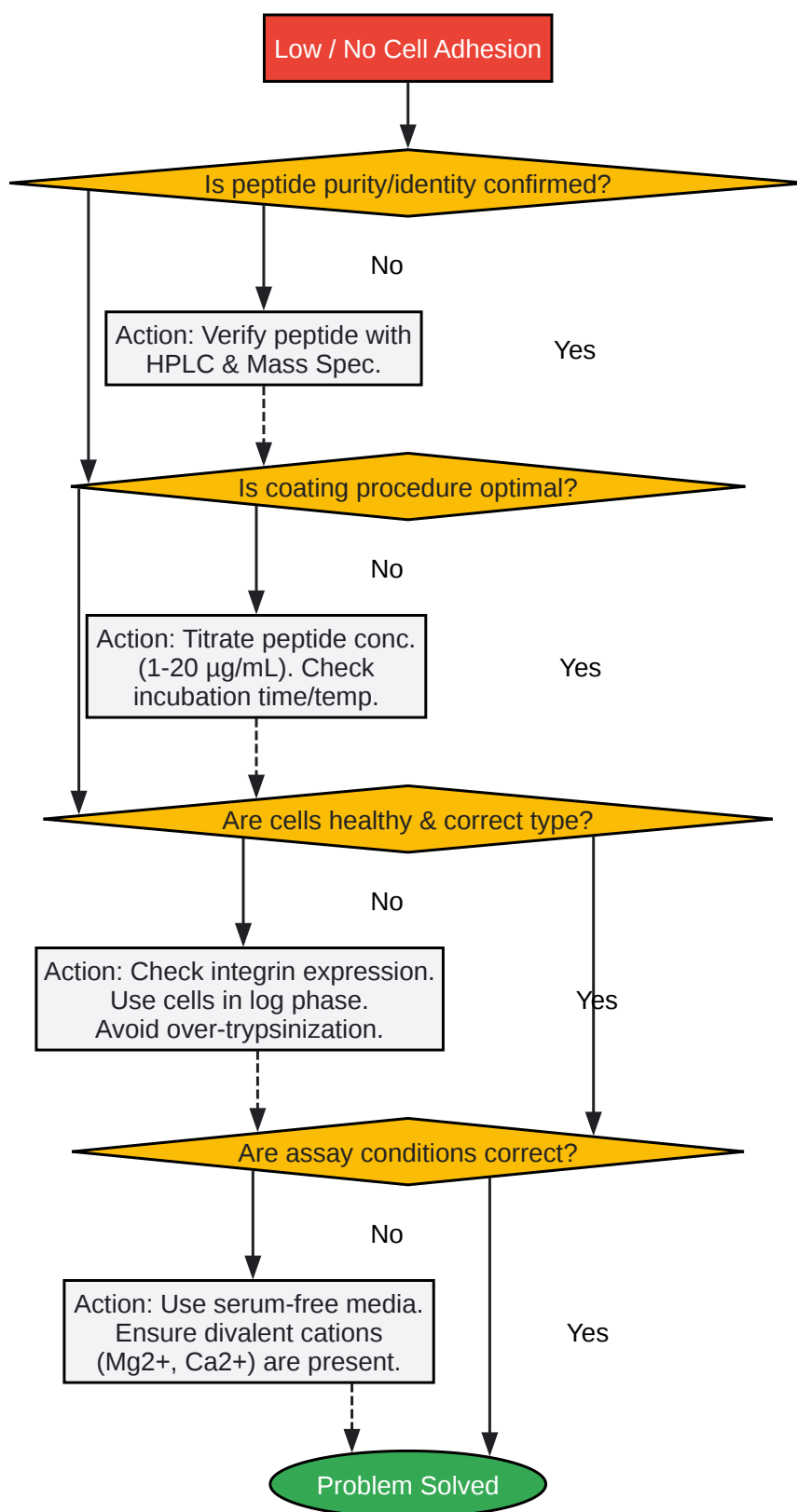

[Click to download full resolution via product page](#)

Caption: Troubleshooting flowchart for poor cell adhesion on peptide-coated surfaces.

Integrin-Mediated Signaling Pathway

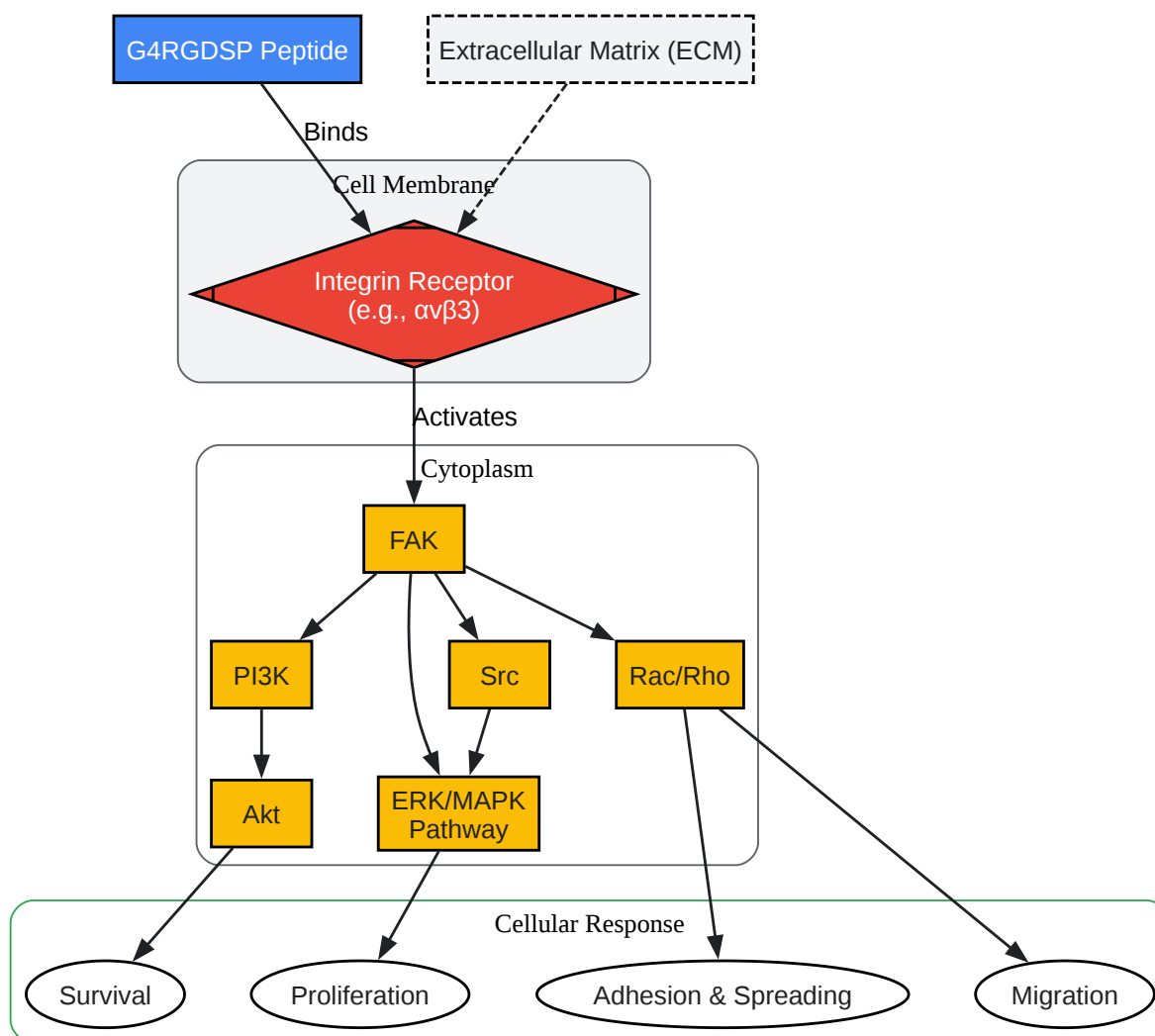

[Click to download full resolution via product page](#)

Caption: Simplified RGD-integrin outside-in signaling cascade.

Need Custom Synthesis?

BenchChem offers custom synthesis for rare earth carbides and specific isotopic labeling.

Email: info@benchchem.com or [Request Quote Online](#).

References

- 1. RGDSP-Decorated Hyaluronate Hydrogels Facilitate Rapid 3D Expansion of Amylase Expressing Salivary Gland Progenitor Cells - PMC [[pmc.ncbi.nlm.nih.gov](https://pubmed.ncbi.nlm.nih.gov)]
- 2. [researchgate.net](https://www.researchgate.net) [[researchgate.net](https://www.researchgate.net)]
- 3. Study on galactosylated sodium alginate for enhancing HepG2 Cells adhesion and 3D printability - PubMed [pubmed.ncbi.nlm.nih.gov]
- To cite this document: BenchChem. [Technical Support Center: G4RGDSP Peptide Bioactivity Assessment]. BenchChem, [2026]. [Online PDF]. Available at: [<https://www.benchchem.com/product/b15609231/docs#technical-support-center-g4rgdsp-peptide-bioactivity-assessment>]

Disclaimer & Data Validity:

The information provided in this document is for Research Use Only (RUO) and is strictly not intended for diagnostic or therapeutic procedures. While BenchChem strives to provide accurate protocols, we make no warranties, express or implied, regarding the fitness of this product for every specific experimental setup.

Technical Support: The protocols provided are for reference purposes. Unsure if this reagent suits your experiment?

Need Industrial/Bulk Grade? [Request Custom Synthesis Quote](#)

BenchChem

Our mission is to be the trusted global source of essential and advanced chemicals, empowering scientists and researchers to drive progress in science and industry.

Contact

Address: 3281 E Guasti Rd

Ontario, CA 91761, United States

Phone: (601) 213-4426

Email: info@benchchem.com

[Contact our Ph.D. Support Team for a compatibility check](#)