

# Technical Support Center: Flow Cytometry Experiments with Des-ethyl-carafiban

**Author:** BenchChem Technical Support Team. **Date:** April 2026

## Compound of Interest

Compound Name: *Des-ethyl-carafiban*

CAS No.: *170565-45-4*

Cat. No.: *B15609023*

[Get Quote](#)

This technical support center provides troubleshooting guidance and frequently asked questions (FAQs) for researchers utilizing **Des-ethyl-carafiban** in flow cytometry experiments. While specific data on **Des-ethyl-carafiban** is limited in publicly available literature, this guide addresses common artifacts and issues encountered in flow cytometry that are relevant to experiments involving novel small molecules.

## Troubleshooting Guide

### Issue 1: High Background Signal or Non-Specific Staining

High background fluorescence can obscure genuine signals, making data interpretation difficult.

Possible Causes and Solutions:

Cause	Recommended Solution
Excessive Antibody Concentration	Titrate your antibodies to determine the optimal concentration that provides a good signal-to-noise ratio.
Insufficient Washing Steps	Increase the number of wash steps after antibody incubation to remove unbound antibodies. Consider adding a small amount of detergent like Tween-20 to the wash buffer. <sup>[1]</sup>
Fc Receptor-Mediated Binding	If working with cells expressing Fc receptors (e.g., immune cells), block these receptors with an Fc blocking reagent before adding your primary antibodies.
Dead Cells	Dead cells can non-specifically bind antibodies. Use a viability dye to exclude dead cells from your analysis during gating. <sup>[1][2][3][4][5]</sup>
Autofluorescence	Some cell types are naturally autofluorescent. Run an unstained control to assess the level of autofluorescence and consider using brighter fluorochromes or a different laser/filter combination if necessary.

## Issue 2: Weak or No Signal

A lack of signal can indicate a problem with the experimental setup or the reagents.

Possible Causes and Solutions:

Cause	Recommended Solution
Insufficient Antibody Concentration	Increase the antibody concentration. Ensure you have performed a proper titration.
Incorrect Fluorochrome Choice	For antigens with low expression, use a bright fluorochrome.
Improper Antibody Storage	Ensure antibodies have been stored according to the manufacturer's instructions and have not expired.
Loss of Target Antigen	Cell preparation methods, such as enzymatic digestion, can sometimes damage cell surface epitopes. Consider using alternative, gentler dissociation methods.
Instrument Settings	Ensure the correct laser and filter settings are used for the fluorochromes in your panel. Check that the photomultiplier tube (PMT) voltages are set appropriately.

## Issue 3: Presence of Cellular Aggregates and Debris

Cell clumps and debris can clog the flow cytometer and lead to inaccurate results.

Possible Causes and Solutions:

Cause	Recommended Solution
Improper Sample Preparation	Gently pipette the cell suspension before analysis to break up clumps. For adherent cells, ensure complete dissociation into a single-cell suspension.[3]
Cellular Debris	Centrifuge the sample at a low speed to pellet the cells and carefully aspirate the supernatant containing debris.
Cell Clumping	Filter the cell suspension through a cell strainer (e.g., 40-70 $\mu\text{m}$ ) before running on the cytometer.[3][5]
High Cell Density	Resuspend cells at an appropriate concentration (typically $1 \times 10^6$ to $1 \times 10^7$ cells/mL) to prevent aggregation.[3]

## Frequently Asked Questions (FAQs)

Q1: How can I distinguish between true cellular events and debris in my flow cytometry data?

A1: Debris typically has lower forward scatter (FSC) and side scatter (SSC) signals compared to intact cells. You can use a gating strategy based on FSC vs. SSC to exclude debris from your analysis. It is also recommended to perform a visual inspection of your cell suspension under a microscope before running it on the flow cytometer to assess the amount of debris.[6][7]

Q2: What is spectral overlap and how can I correct for it?

A2: Spectral overlap, or spillover, occurs when the emission spectrum of one fluorochrome is detected in the channel of another.[8][9] This can lead to false positive signals. To correct for this, a process called compensation is used.[8][9] This involves running single-color controls for each fluorochrome in your panel to determine the amount of spectral overlap and then applying a mathematical correction to the data.[9]

Q3: Why is it important to use a viability dye in my experiments with **Des-ethyl-carafiban**?

A3: A viability dye is crucial for distinguishing between live and dead cells. Dead cells have compromised membranes and can non-specifically bind antibodies, leading to false-positive results.<sup>[2][3][4]</sup> By including a viability dye, you can gate out the dead cell population and ensure that your analysis is focused on the live, healthy cells that have been affected by your experimental treatment with **Des-ethyl-carafiban**.<sup>[1][2][5]</sup>

Q4: How can I minimize artifacts caused by cell doublets?

A4: Cell doublets, or two cells passing through the laser at the same time, can be mistaken for single, brighter cells. To exclude doublets, you can use pulse geometry gating, plotting the height (H) or width (W) of the fluorescence signal against the area (A) of the signal (e.g., FSC-A vs. FSC-H). Single cells will have a proportional relationship between these parameters, while doublets will deviate from this.<sup>[1][2][6]</sup>

## Hypothetical Experimental Protocol: Assessing the Effect of **Des-ethyl-carafiban** on Platelet Activation

This protocol provides a hypothetical example of how to assess the inhibitory effect of **Des-ethyl-carafiban** on platelet activation by measuring P-selectin (CD62P) expression using flow cytometry.

### 1. Sample Preparation:

- Collect whole blood from healthy donors into citrate tubes.
- Prepare platelet-rich plasma (PRP) by centrifuging the whole blood at a low speed (e.g., 200 x g) for 15 minutes at room temperature.
- Carefully collect the upper PRP layer.

### 2. Treatment with **Des-ethyl-carafiban**:

- Aliquot the PRP into separate tubes.
- Add varying concentrations of **Des-ethyl-carafiban** (or vehicle control) to the PRP and incubate for a predetermined time at 37°C.

### 3. Platelet Activation:

- Induce platelet activation by adding a known agonist, such as ADP or thrombin, to the PRP and incubate for 10 minutes at 37°C.
- Include a resting (unactivated) platelet control.

### 4. Antibody Staining:

- Add a fluorochrome-conjugated anti-CD62P antibody to each tube.
- Incubate for 20 minutes at room temperature in the dark.

### 5. Sample Acquisition:

- Fix the samples with 1% paraformaldehyde.
- Acquire the samples on a flow cytometer, collecting a sufficient number of events for statistical analysis.

### 6. Data Analysis:

- Gate on the platelet population based on their characteristic FSC and SSC properties.
- Quantify the percentage of CD62P-positive platelets and the mean fluorescence intensity (MFI) of CD62P expression.

## Hypothetical Data Presentation

The following table summarizes hypothetical data from an experiment investigating the effect of **Des-ethyl-carafiban** on ADP-induced P-selectin expression on platelets.

Treatment	Des-ethyl-carafiban (µM)	% CD62P Positive Platelets	Mean Fluorescence Intensity (MFI) of CD62P
Resting (Unactivated)	0	5.2	150
ADP-activated (Vehicle)	0	85.6	2500
ADP-activated	1	62.3	1800
ADP-activated	10	35.1	950
ADP-activated	50	15.8	400

## Visualizations

Below are diagrams illustrating key concepts in flow cytometry troubleshooting and a hypothetical signaling pathway for **Des-ethyl-carafiban**.

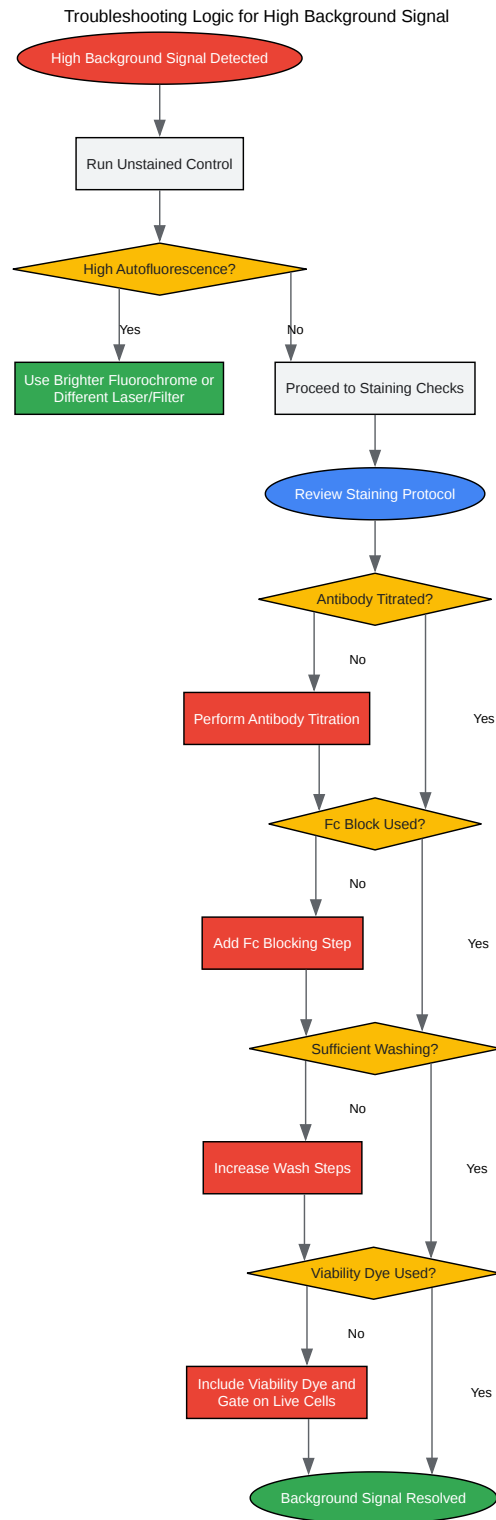

[Click to download full resolution via product page](#)

Troubleshooting workflow for high background signal.

## General Gating Strategy for Flow Cytometry

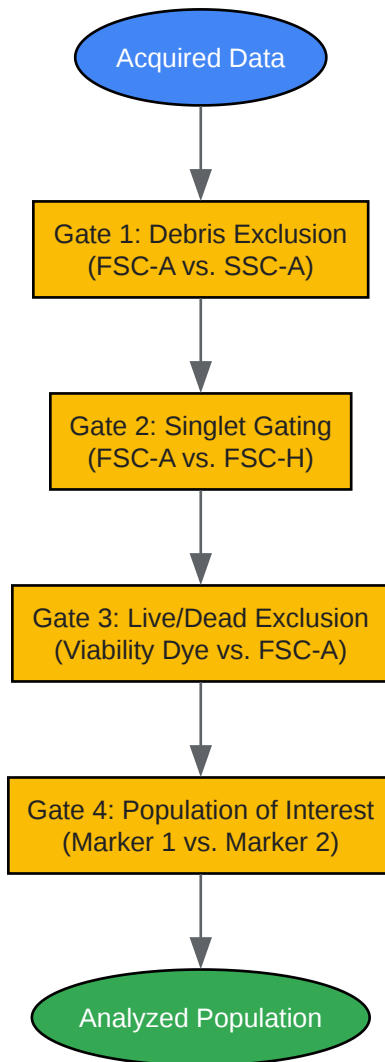

[Click to download full resolution via product page](#)

A typical sequential gating strategy for data analysis.

Hypothetical Signaling Pathway for Des-ethyl-carafiban in Platelets

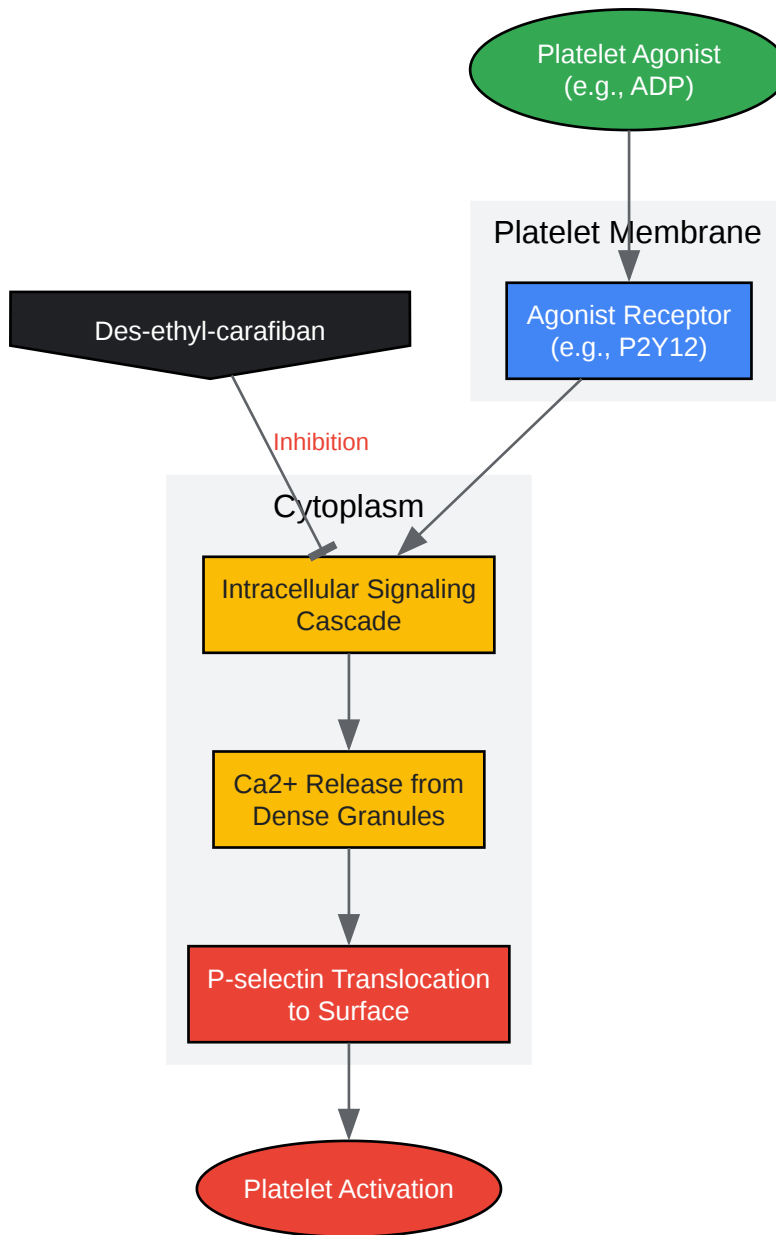

[Click to download full resolution via product page](#)

Hypothetical mechanism of action for **Des-ethyl-carafiban**.

### Need Custom Synthesis?

BenchChem offers custom synthesis for rare earth carbides and specific isotopic labeling.

Email: [info@benchchem.com](mailto:info@benchchem.com) or [Request Quote Online](#).

## References

- [1. stemcell.com](https://www.stemcell.com) [stemcell.com]
- [2. Newsletter: Gating Strategies - FluoroFinder](https://www.fluorofinder.com) [fluorofinder.com]
- [3. Ten Top Tips for Flow Cytometry](https://www.jacksonimmuno.com) [jacksonimmuno.com]
- [4. bio-rad-antibodies.com](https://www.bio-rad-antibodies.com) [bio-rad-antibodies.com]
- [5. bosterbio.com](https://www.bosterbio.com) [bosterbio.com]
- [6. bosterbio.com](https://www.bosterbio.com) [bosterbio.com]
- [7. bitesizebio.com](https://www.bitesizebio.com) [bitesizebio.com]
- [8. Spectral Overlap | CYM](https://www.cytometry.mlsascp.com) [cytometry.mlsascp.com]
- [9. bio-rad-antibodies.com](https://www.bio-rad-antibodies.com) [bio-rad-antibodies.com]
- To cite this document: BenchChem. [Technical Support Center: Flow Cytometry Experiments with Des-ethyl-carafiban]. BenchChem, [2026]. [Online PDF]. Available at: [\[https://www.benchchem.com/product/b15609023/docs#technical-support-center-flow-cytometry-experiments-with-des-ethyl-carafiban\]](https://www.benchchem.com/product/b15609023/docs#technical-support-center-flow-cytometry-experiments-with-des-ethyl-carafiban)

---

### Disclaimer & Data Validity:

The information provided in this document is for Research Use Only (RUO) and is strictly not intended for diagnostic or therapeutic procedures. While BenchChem strives to provide accurate protocols, we make no warranties, express or implied, regarding the fitness of this product for every specific experimental setup.

**Technical Support:** The protocols provided are for reference purposes. Unsure if this reagent suits your experiment?

**Need Industrial/Bulk Grade?** [Request Custom Synthesis Quote](#)

# BenchChem

Our mission is to be the trusted global source of essential and advanced chemicals, empowering scientists and researchers to drive progress in science and industry.

## Contact

Address: 3281 E Guasti Rd

Ontario, CA 91761, United States

Phone: (601) 213-4426

Email: [info@benchchem.com](mailto:info@benchchem.com)

[Contact our Ph.D. Support Team for a compatibility check](#)