

preventing off-target effects of LM22B-10 in experiments

Author: BenchChem Technical Support Team. **Date:** April 2026

Compound of Interest

Compound Name: LM22B-10
Cat. No.: B15608413

[Get Quote](#)

Technical Support Center: LM22B-10

Welcome to the technical support center for the TrkB/TrkC co-agonist, **LM22B-10**. This resource is intended for researchers, scientists, and drug development professionals to provide guidance on preventing off-target effects and to offer troubleshooting support for experiments involving **LM22B-10**.

Frequently Asked Questions (FAQs)

Q1: What is **LM22B-10** and what are its primary targets?

A1: **LM22B-10** is a small molecule co-activator of the Tropomyosin receptor kinase B (TrkB) and TrkC neurotrophin receptors.[1][2] It has been demonstrated to promote neuronal survival and neurite outgrowth by activating these two receptors and their downstream signaling pathways, including AKT and ERK.[2][3]

Q2: What are the known off-targets of **LM22B-10**?

A2: **LM22B-10** has been shown to be highly selective for TrkB and TrkC. It does not exhibit significant activity at the TrkA receptor or the p75 neurotrophin receptor (p75NTR).[4][5]

Furthermore, in a screening panel of 57 other receptors and transporters, **LM22B-10** showed no significant binding activity, indicating a low potential for broad off-target effects.[6]

Q3: What is the recommended working concentration for **LM22B-10** in in vitro experiments?

A3: The optimal concentration of **LM22B-10** will depend on the specific assay and cell type. However, a good starting point for most cell-based assays is in the range of 200 nM to 1 μ M. The EC50 for its neurotrophic activity is reported to be between 200-300 nM.[2] For promoting neurite outgrowth, a concentration of 1000 nM (1 μ M) has been shown to be effective.[2] It is always recommended to perform a dose-response curve to determine the optimal concentration for your specific experimental setup.

Q4: How should I prepare and store **LM22B-10** stock solutions?

A4: **LM22B-10** is soluble in DMSO and ethanol.[6] For cell culture experiments, it is common to prepare a high-concentration stock solution in DMSO (e.g., 10 mM) and then dilute it to the final working concentration in your culture medium. To avoid solubility issues in aqueous solutions, ensure the final DMSO concentration in your culture medium is low (typically \leq 0.1%). For in vitro experiments, one study dissolved **LM22B-10** in 0.04 N HCl in water, which was then diluted into the culture medium.[7] Stock solutions should be stored at -20°C or -80°C to maintain stability.[8] Avoid repeated freeze-thaw cycles by preparing single-use aliquots.

Q5: Can **LM22B-10** be used in in vivo studies?

A5: Yes, **LM22B-10** is brain-penetrant and has been used in in vivo studies.[6] Doses of 0.5 mg/kg and 50 mg/kg have been shown to activate TrkB and TrkC in mice.[2]

Troubleshooting Guide

This guide provides solutions to common issues that may arise during experiments with **LM22B-10**, with a focus on distinguishing on-target from potential off-target effects.

Observed Problem	Potential Cause	Suggested Solution
<p>Unexpected or inconsistent cellular phenotype.</p>	<p>1. Off-target effect: The observed phenotype may be due to interaction with an unintended cellular target. 2. Compound degradation: The compound may have degraded due to improper storage or handling. 3. Incorrect concentration: Pipetting errors or incorrect calculations may lead to a suboptimal or toxic concentration.</p>	<p>1. Confirm on-target engagement: Use a structurally unrelated TrkB/TrkC agonist to see if the phenotype is reproduced. Perform experiments in cell lines lacking TrkB or TrkC (knockout or knockdown) to see if the effect is abolished. 2. Use fresh compound: Prepare fresh dilutions from a new stock aliquot for each experiment. 3. Verify concentration: Perform a dose-response experiment to identify the optimal concentration. Double-check all calculations and pipette calibrations.</p>
<p>High levels of cell death or cytotoxicity.</p>	<p>1. Concentration is too high: The concentration of LM22B-10 may be in a toxic range for your specific cell type. 2. Solvent toxicity: The concentration of the vehicle (e.g., DMSO) may be too high.</p>	<p>1. Perform a cell viability assay (e.g., MTT or CellTiter-Glo): Determine the cytotoxic threshold of LM22B-10 for your cells and use concentrations below this for functional assays. 2. Maintain low solvent concentration: Ensure the final concentration of the solvent is typically below 0.1% and include a vehicle-only control in all experiments.</p>
<p>No observable effect of LM22B-10.</p>	<p>1. Suboptimal concentration: The concentration used may be too low to elicit a response. 2. Low receptor expression:</p>	<p>1. Increase concentration: Perform a dose-response experiment with a wider range of concentrations. 2. Verify</p>

	<p>The cells may not express sufficient levels of TrkB or TrkC. 3. Compound inactivity: The compound may have degraded.</p>	<p>receptor expression: Confirm the presence of TrkB and TrkC in your cell line using Western blot or qPCR. 3. Use a fresh aliquot: Prepare a new working solution from a properly stored stock.</p>
<p>Activation of unexpected signaling pathways.</p>	<p>1. Signaling pathway crosstalk: Activation of TrkB/TrkC may indirectly influence other pathways. 2. Cell-type specific signaling: The downstream signaling from TrkB/TrkC can vary between different cell types.</p>	<p>1. Use specific inhibitors: Co-treat with inhibitors of the unexpected pathway to see if the phenotype is reversed. 2. Literature review: Investigate the known signaling networks in your specific cell model.</p>

Quantitative Data Summary

The following tables summarize key quantitative parameters for **LM22B-10**.

Table 1: Potency and Efficacy of **LM22B-10**

Parameter	Receptor	Value	Reference
EC50 (Receptor Activation)	TrkB	1.8 μ M	[1]
TrkC	2.5 μ M	[1]	
EC50 (Neurotrophic Activity)	N/A	200-300 nM	[2]
Maximal Neurotrophic Survival	TrkB	53 \pm 7.2% above BDNF (at 0.7 nM)	[2]
TrkC	91 \pm 8.6% above NT-3 (at 0.7 nM)	[2]	

Table 2: Recommended Concentration Ranges for In Vitro Assays

Assay Type	Recommended Starting Concentration	Reference
Neuronal Survival	0.1 - 10 μ M	[1]
Neurite Outgrowth	1 μ M	[2]
Progenitor Cell Proliferation	1 μ M	[7]
Signaling Pathway Activation (Western Blot)	1 μ M	[3]

Experimental Protocols

Below are detailed methodologies for key experiments to validate the on-target effects of **LM22B-10** and investigate potential off-target effects.

Protocol 1: Western Blot for TrkB/TrkC Signaling Pathway Activation

Objective: To confirm that **LM22B-10** activates the TrkB and TrkC receptors and their downstream signaling pathways (e.g., Akt, ERK).

Materials:

- Cells expressing TrkB and/or TrkC
- **LM22B-10**
- Cell lysis buffer (e.g., RIPA buffer with protease and phosphatase inhibitors)
- BCA protein assay kit
- SDS-PAGE gels and running buffer
- PVDF membrane

- Transfer buffer
- Blocking buffer (e.g., 5% BSA or non-fat milk in TBST)
- Primary antibodies: anti-phospho-TrkB (Y816), anti-phospho-TrkC (Y820), anti-total-TrkB, anti-total-TrkC, anti-phospho-Akt (S473), anti-total-Akt, anti-phospho-ERK1/2 (T202/Y204), anti-total-ERK1/2, and a loading control (e.g., β -actin or GAPDH)
- HRP-conjugated secondary antibodies
- ECL detection reagent

Procedure:

- Cell Treatment: Plate cells and allow them to adhere. Serum-starve the cells if necessary, then treat with **LM22B-10** (e.g., 1 μ M) or vehicle control for a predetermined time (e.g., 15-30 minutes).
- Cell Lysis: Wash cells with ice-cold PBS and lyse with lysis buffer.
- Protein Quantification: Determine the protein concentration of each lysate using a BCA assay.
- SDS-PAGE and Transfer: Separate equal amounts of protein on an SDS-PAGE gel and transfer to a PVDF membrane.
- Blocking: Block the membrane with blocking buffer for 1 hour at room temperature.
- Primary Antibody Incubation: Incubate the membrane with the desired primary antibody overnight at 4°C.
- Secondary Antibody Incubation: Wash the membrane and incubate with the appropriate HRP-conjugated secondary antibody for 1 hour at room temperature.
- Detection: Wash the membrane and visualize the protein bands using an ECL detection system.

- Analysis: Quantify the band intensities and normalize the phosphorylated protein levels to the total protein levels.

Protocol 2: Neurite Outgrowth Assay

Objective: To assess the ability of **LM22B-10** to promote neurite outgrowth in a neuronal cell line or primary neurons.

Materials:

- Neuronal cells (e.g., PC12, SH-SY5Y, or primary neurons)
- **LM22B-10**
- Cell culture plates or coverslips coated with an appropriate substrate (e.g., poly-L-lysine, laminin)
- Fixative (e.g., 4% paraformaldehyde)
- Permeabilization buffer (e.g., 0.1% Triton X-100 in PBS)
- Blocking solution (e.g., 5% BSA in PBS)
- Primary antibody against a neuronal marker (e.g., β -III tubulin)
- Fluorescently labeled secondary antibody
- DAPI for nuclear staining
- Microscope with imaging software

Procedure:

- Cell Seeding: Seed neuronal cells at a low density on coated plates or coverslips.
- Treatment: Treat the cells with various concentrations of **LM22B-10** or a vehicle control.
- Incubation: Incubate the cells for 24-72 hours to allow for neurite extension.

- **Fixation and Staining:** Fix the cells, permeabilize them, and block non-specific binding. Incubate with the primary antibody, followed by the fluorescently labeled secondary antibody and DAPI.
- **Imaging:** Acquire images of the stained cells using a fluorescence microscope.
- **Analysis:** Quantify neurite length and branching using image analysis software (e.g., ImageJ with the NeuronJ plugin).

Visualizations

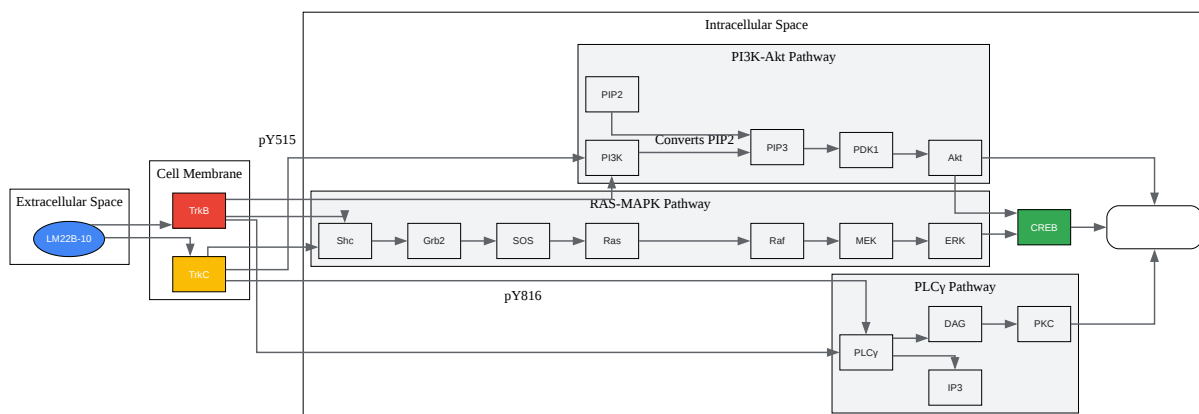

[Click to download full resolution via product page](#)

Caption: TrkB and TrkC Signaling Pathways Activated by **LM22B-10**.

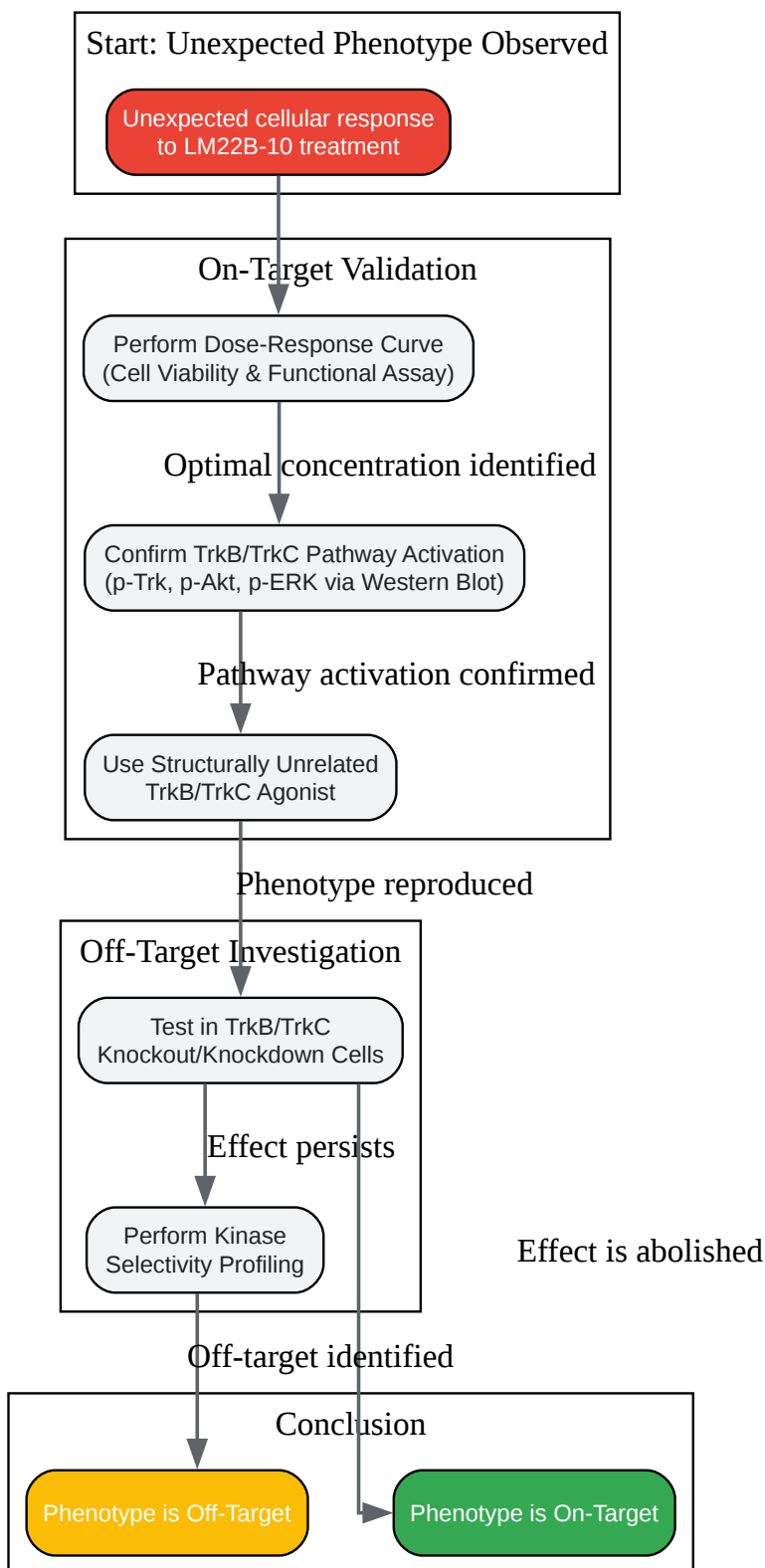

[Click to download full resolution via product page](#)

Caption: Experimental Workflow for Investigating Unexpected Phenotypes.



[Click to download full resolution via product page](#)

Caption: Troubleshooting Decision Tree for Unexpected Results.

Need Custom Synthesis?

BenchChem offers custom synthesis for rare earth carbides and specific isotopic labeling.

Email: info@benchchem.com or [Request Quote Online](#).

References

- 1. LM22B-10 | activator of TrkB/TrkC (Tropomyosin-receptor kinase) neurotrophin receptor | CAS 342777-54-2 | Buy LM22B10 from Supplier InvivoChem [[invivochem.com](https://www.invivochem.com)]
- 2. [medchemexpress.com](https://www.medchemexpress.com) [[medchemexpress.com](https://www.medchemexpress.com)]
- 3. [researchgate.net](https://www.researchgate.net) [[researchgate.net](https://www.researchgate.net)]
- 4. [researchgate.net](https://www.researchgate.net) [[researchgate.net](https://www.researchgate.net)]
- 5. [researchgate.net](https://www.researchgate.net) [[researchgate.net](https://www.researchgate.net)]
- 6. [rndsystems.com](https://www.rndsystems.com) [[rndsystems.com](https://www.rndsystems.com)]
- 7. A Small-Molecule TrkB/TrkC Ligand Promotes Neurogenesis and Behavioral Recovery Following Traumatic Brain Injury - PMC [[pmc.ncbi.nlm.nih.gov](https://pubmed.ncbi.nlm.nih.gov)]
- 8. [selleckchem.com](https://www.selleckchem.com) [[selleckchem.com](https://www.selleckchem.com)]
- To cite this document: BenchChem. [preventing off-target effects of LM22B-10 in experiments]. BenchChem, [2026]. [Online PDF]. Available at: [<https://www.benchchem.com/product/b15608413/docs#preventing-off-target-effects-of-lm22b-10-in-experiments>]

Disclaimer & Data Validity:

The information provided in this document is for Research Use Only (RUO) and is strictly not intended for diagnostic or therapeutic procedures. While BenchChem strives to provide accurate protocols, we make no warranties, express or implied, regarding the fitness of this product for every specific experimental setup.

Technical Support: The protocols provided are for reference purposes. Unsure if this reagent suits your experiment?

Need Industrial/Bulk Grade? [Request Custom Synthesis Quote](#)

BenchChem

Our mission is to be the trusted global source of essential and advanced chemicals, empowering scientists and researchers to drive progress in science and industry.

Contact

Address: 3281 E Guasti Rd
Ontario, CA 91761, United States
Phone: (601) 213-4426
Email: info@benchchem.com

[Contact our Ph.D. Support Team for a compatibility check](#)