

Technical Support Center: LP17-Based Experimental Setups

Author: BenchChem Technical Support Team. **Date:** April 2026

Compound of Interest

Compound Name: LP17 (human)

Cat. No.: B15608618

[Get Quote](#)

This technical support center provides troubleshooting guides and frequently asked questions (FAQs) for researchers, scientists, and drug development professionals working with the TREM-1 inhibitory peptide, LP17.

Frequently Asked Questions (FAQs)

Q1: What is LP17 and what is its mechanism of action?

A1: LP17 is a 17-amino acid synthetic peptide (LQVTDSGLYRCVIYHPP) that acts as an inhibitor of the Triggering Receptor Expressed on Myeloid cells-1 (TREM-1).[1] TREM-1 is an immunoreceptor found on neutrophils, monocytes, and macrophages that amplifies the inflammatory response.[2] LP17 is thought to function as a decoy receptor, competing with the natural ligands of TREM-1, thereby preventing the activation of pro-inflammatory signaling pathways.[3][4][5]

Q2: What are the common applications of LP17 in research?

A2: LP17 is primarily used in pre-clinical studies of inflammatory diseases to investigate the role of the TREM-1 signaling pathway and to evaluate the therapeutic potential of TREM-1

inhibition. Common applications include in vitro studies using cell lines (e.g., macrophages) and primary cells, as well as in vivo animal models of sepsis, endotoxemia, and colitis.[3][6][7]

Q3: How should LP17 be stored and handled?

A3: For long-term storage, it is recommended to store LP17 at -80°C for up to six months. For shorter periods, storage at -20°C for up to one month is acceptable. The peptide should be stored in a sealed container, protected from moisture and light, and under a nitrogen atmosphere if possible. When preparing a stock solution with water, it is advised to filter and sterilize it using a 0.22 µm filter before use.[1]

Q4: What is a typical effective dose of LP17 in animal models?

A4: The effective dose of LP17 can vary depending on the animal model and the specific experimental conditions. In a mouse model of ischemia, intranasal administration of 0.5 or 1 mg/kg daily for three days has been shown to be effective.[1] In a cecal ligation and puncture (CLP) mouse model of sepsis, a single injection of 100 µg of LP17 at various time points post-CLP has demonstrated protective effects.[8]

Troubleshooting Guides

In Vitro Cell-Based Assays

Problem: High variability in cytokine measurements between replicates after LP17 treatment and LPS stimulation.

- Possible Cause 1: Inconsistent cell health or density.
 - Solution: Ensure a consistent cell seeding density across all wells. Regularly check cell viability using methods like Trypan Blue exclusion to ensure cells are healthy and responsive.
- Possible Cause 2: Pipetting errors.
 - Solution: Use calibrated pipettes and proper pipetting techniques. When preparing dilutions of LP17 or LPS, ensure thorough mixing before adding to the cells.
- Possible Cause 3: Contamination of reagents.

- Solution: Use fresh, sterile reagents. Filter-sterilize all solutions, including the LP17 stock solution, before use.[1]

Problem: No significant reduction in pro-inflammatory cytokines (e.g., TNF- α , IL-6) with LP17 treatment.

- Possible Cause 1: Suboptimal concentration of LP17.
 - Solution: Perform a dose-response experiment to determine the optimal concentration of LP17 for your specific cell type and experimental conditions.[9] Concentrations in the range of 1 to 10 μ M have been shown to be effective in in vitro models.[1]
- Possible Cause 2: Inactive LP17 peptide.
 - Solution: Verify the integrity and purity of the LP17 peptide. Ensure it has been stored correctly to prevent degradation.[1] Consider purchasing a new batch from a reputable supplier.
- Possible Cause 3: Low TREM-1 expression on the cells.
 - Solution: Confirm TREM-1 expression on your target cells using techniques like flow cytometry or qPCR. Some cell lines may have low or no TREM-1 expression.

In Vivo Animal Models

Problem: Lack of therapeutic effect of LP17 in a sepsis model.

- Possible Cause 1: Inadequate dosage or route of administration.
 - Solution: Optimize the dose and administration route of LP17 for your specific animal model. Intraperitoneal (i.p.) and intravenous (i.v.) injections are common routes.[7][10] A dose of 100 μ g per mouse has been used effectively in CLP-induced sepsis models.[8]
- Possible Cause 2: Timing of LP17 administration.
 - Solution: The timing of LP17 administration relative to the inflammatory insult is critical. In endotoxemia models, LP17 has shown efficacy when given both before and after the LPS challenge.[3][7] Test different time points of administration in your model.

- Possible Cause 3: Poor bioavailability or stability of the peptide in vivo.
 - Solution: While LP17 has shown in vivo efficacy, peptide stability can be a concern. Ensure the peptide is properly dissolved and administered promptly after preparation.

Quantitative Data Summary

Table 1: In Vitro Efficacy of LP17 on Cytokine Production

Cell Type	Stimulant	LP17 Concentration	Outcome	Reference
Microglia	Oxygen-Glucose Deprivation	1 or 10 μ M	Substantial decrease in mRNA levels of pro-inflammatory cytokines and chemokines	[1]
Monocytes	LPS	Dose-dependent	Reduction in TNF- α and IL-1 β release	[3][7]
RAW264.7 Macrophages	rmCIRP	Dose-dependent	Inhibition of TNF- α production	[10]

Table 2: In Vivo Efficacy of LP17 in Animal Models

Animal Model	LP17 Dose	Administration Route	Key Findings	Reference
Mouse Ischemia	1 mg/kg	Intranasal	Significantly reduced infarct volume and neuronal injury	[1]
Mouse Endotoxemia	100 µg	Not specified	Reduced serum levels of TNF-α and IL-1β, and improved survival	[3][8]
Mouse CLP Sepsis	100 µg	Not specified	Partial protection from lethality	[8]
Rat Sepsis (LPS-induced)	Not specified	Not specified	Attenuated sepsis severity, improved hemodynamic parameters, and reduced serum pro-inflammatory cytokines	[3][7]
Mouse Colitis (DSS-induced)	Not specified	Not specified	Moderate signs of histopathological alterations compared to severe alterations in the control group	[6]

Experimental Protocols

Protocol 1: In Vitro Inhibition of LPS-Induced Cytokine Production in Macrophages

- **Cell Culture:** Plate murine macrophage-like cells (e.g., RAW 264.7) in a 24-well plate at a density of 5×10^5 cells/well and allow them to adhere overnight.
- **LP17 Pre-treatment:** Prepare a stock solution of LP17 in sterile, endotoxin-free water or PBS. Dilute the stock solution to the desired final concentrations (e.g., 1, 5, 10 μ M) in cell culture medium. Remove the old medium from the cells and add the medium containing LP17. Incubate for 1 hour.
- **LPS Stimulation:** Prepare a stock solution of lipopolysaccharide (LPS). Dilute the LPS to a final concentration of 100 ng/mL in cell culture medium. Add the LPS solution to the wells already containing LP17.
- **Incubation:** Incubate the plate for 6-24 hours at 37°C in a humidified incubator with 5% CO₂.
- **Cytokine Measurement:** Collect the cell culture supernatants and centrifuge to remove any cellular debris. Measure the concentration of pro-inflammatory cytokines (e.g., TNF- α , IL-6, IL-1 β) in the supernatants using an enzyme-linked immunosorbent assay (ELISA) kit according to the manufacturer's instructions.
- **Data Analysis:** Compare the cytokine concentrations in the LP17-treated groups to the LPS-only control group.

Protocol 2: In Vivo Murine Model of LPS-Induced Endotoxemia

- **Animal Handling:** Acclimatize male Balb/c mice (8-10 weeks old) for at least one week before the experiment.
- **LP17 Administration:** Prepare a solution of LP17 in sterile saline. Administer LP17 (e.g., 100 μ g per mouse) via intraperitoneal (i.p.) injection 1 hour before or up to 4 hours after the LPS challenge.^{[3][7]} A control group should receive an equivalent volume of sterile saline.
- **LPS Challenge:** Induce endotoxemia by injecting a lethal dose of LPS (e.g., 15 mg/kg) intraperitoneally.

- **Monitoring:** Monitor the mice for signs of sickness (piloerection, lethargy, diarrhea) and survival over a period of 7-10 days.[3][8]
- **Cytokine Analysis (Optional):** At specific time points (e.g., 2 and 4 hours) post-LPS injection, blood samples can be collected via cardiac puncture for the measurement of serum cytokine levels (TNF- α , IL-1 β) using ELISA.[8]
- **Data Analysis:** Compare the survival rates and cytokine levels between the LP17-treated and control groups.

Visualizations

TREM-1 Signaling Pathway Inhibition by LP17

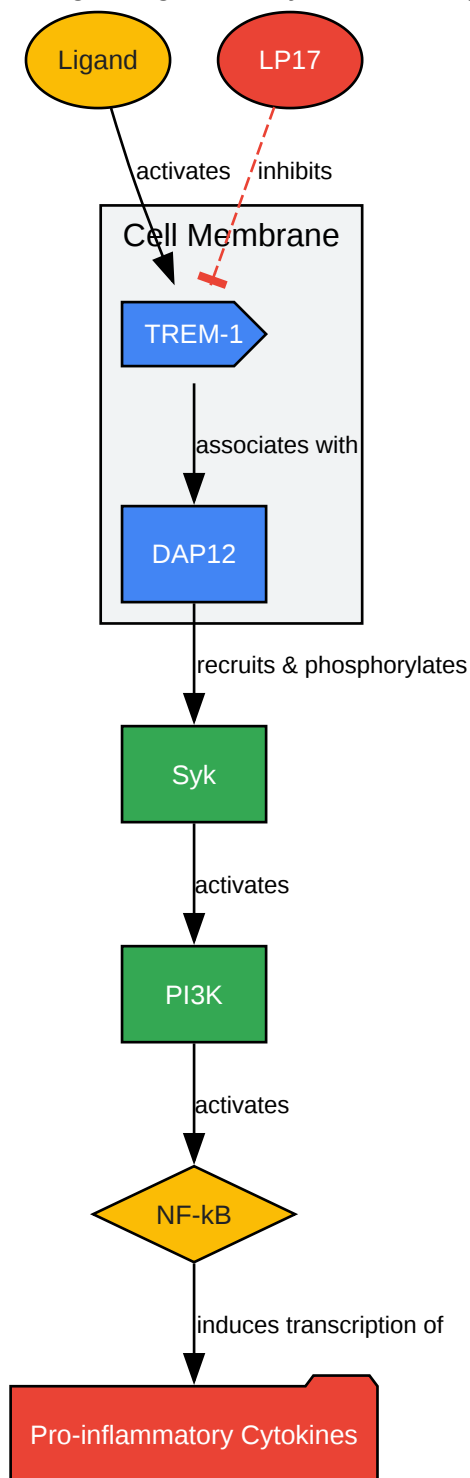

[Click to download full resolution via product page](#)

Caption: TREM-1 signaling pathway and its inhibition by LP17.

General Experimental Workflow for In Vitro LP17 Assay

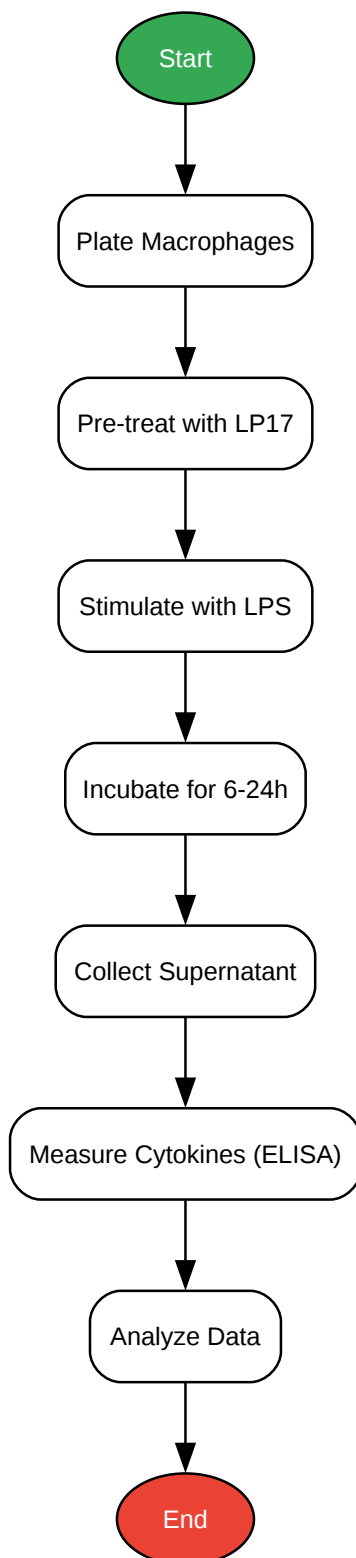

[Click to download full resolution via product page](#)

Need Custom Synthesis?

BenchChem offers custom synthesis for rare earth carbides and specific isotopic labeling.

Email: info@benchchem.com or [Request Quote Online](#).

References

- [1. medchemexpress.com \[medchemexpress.com\]](https://www.medchemexpress.com)
- [2. Triggering Receptor Expressed on Myeloid Cells-1 Inhibitor Targeted to Endothelium Decreases Cell Activation - PMC \[pmc.ncbi.nlm.nih.gov\]](#)
- [3. Frontiers | TREM-1 Modulation Strategies for Sepsis \[frontiersin.org\]](#)
- [4. Frontiers | TREM-1 and TREM-2 as therapeutic targets: clinical challenges and perspectives \[frontiersin.org\]](#)
- [5. researchgate.net \[researchgate.net\]](https://www.researchgate.net)
- [6. TREM-1–expressing intestinal macrophages crucially amplify chronic inflammation in experimental colitis and inflammatory bowel diseases - PMC \[pmc.ncbi.nlm.nih.gov\]](#)
- [7. TREM-1 Modulation Strategies for Sepsis - PMC \[pmc.ncbi.nlm.nih.gov\]](#)
- [8. A Soluble Form of the Triggering Receptor Expressed on Myeloid Cells-1 Modulates the Inflammatory Response in Murine Sepsis - PMC \[pmc.ncbi.nlm.nih.gov\]](#)
- [9. How Do I Perform a Dose-Response Experiment? - FAQ 2188 - GraphPad \[graphpad.com\]](#)
- [10. JCI Insight - Extracellular CIRP as an endogenous TREM-1 ligand to fuel inflammation in sepsis \[insight.jci.org\]](#)
- To cite this document: BenchChem. [Technical Support Center: LP17-Based Experimental Setups]. BenchChem, [2026]. [Online PDF]. Available at: [\[https://www.benchchem.com/product/b15608618/docs#technical-support-center-lp17-based-experimental-setups\]](https://www.benchchem.com/product/b15608618/docs#technical-support-center-lp17-based-experimental-setups)

Disclaimer & Data Validity:

The information provided in this document is for Research Use Only (RUO) and is strictly not intended for diagnostic or therapeutic procedures. While BenchChem strives to provide

accurate protocols, we make no warranties, express or implied, regarding the fitness of this product for every specific experimental setup.

Technical Support: The protocols provided are for reference purposes. Unsure if this reagent suits your experiment?

Need Industrial/Bulk Grade? [Request Custom Synthesis Quote](#)

BenchChem

Our mission is to be the trusted global source of essential and advanced chemicals, empowering scientists and researchers to drive progress in science and industry.

Contact

Address: 3281 E Guasti Rd

Ontario, CA 91761, United States

Phone: (601) 213-4426

Email: info@benchchem.com

[Contact our Ph.D. Support Team for a compatibility check](#)