

# Scrambled Peptide Control for W5Cha Experiments: A Comparative Guide

**Author:** BenchChem Technical Support Team. **Date:** April 2026

## Compound of Interest

Compound Name: C5a Receptor agonist, W5Cha

Cat. No.: B15608044

[Get Quote](#)

For Researchers, Scientists, and Drug Development Professionals

This guide provides a detailed comparison of the **C5a receptor agonist, W5Cha**, and its corresponding scrambled peptide control. The objective is to demonstrate the specificity of W5Cha's activity and to provide researchers with the necessary protocols and conceptual framework for utilizing a scrambled peptide as a negative control in their experiments.

## Introduction to W5Cha and the Imperative for a Scrambled Control

W5Cha is a synthetic hexapeptide agonist that selectively targets the complement C5a receptor (C5aR), a G protein-coupled receptor pivotal in the inflammatory response. Activation of C5aR by its endogenous ligand C5a or synthetic agonists like W5Cha triggers a cascade of intracellular signaling events, leading to cellular responses such as chemotaxis, cytokine release, and calcium mobilization.

To ascertain that the observed biological effects are a direct result of the specific amino acid sequence of W5Cha and not due to non-specific peptide properties like charge or hydrophobicity, a scrambled peptide control is an indispensable tool. A scrambled peptide

control is designed to have the exact same amino acid composition as the active peptide, W5Cha, but with the sequence of amino acids randomized. This ensures that the physicochemical properties are as similar as possible, while the specific receptor-binding motif is disrupted. The ideal scrambled control should exhibit no significant biological activity in assays where W5Cha is active, thereby validating the sequence-specificity of W5Cha's effects.

## Comparative Analysis of W5Cha and Scrambled Peptide Control

The following table summarizes the expected comparative performance of W5Cha and its scrambled peptide control in key functional assays for C5aR activation. The data presented is illustrative, based on the known high potency of C5aR agonists and the anticipated inactivity of a well-designed scrambled control.

Assay	Parameter Measured	W5Cha	Scrambled W5Cha Control	Interpretation
Calcium Mobilization	EC50 (Effective Concentration, 50%)	~0.2 $\mu$ M	> 100 $\mu$ M (No significant response)	W5Cha potently induces intracellular calcium release via C5aR activation, while the scrambled control is inactive, demonstrating sequence specificity.
Neutrophil Chemotaxis	Chemotactic Index at 1 $\mu$ M	3.5 $\pm$ 0.4	1.1 $\pm$ 0.2 (Baseline)	W5Cha effectively induces directed migration of neutrophils, a key function of C5aR activation. The scrambled control shows no chemotactic activity.
Cytokine Release (TNF- $\alpha$ )	Fold Increase over Baseline at 1 $\mu$ M	8.2 $\pm$ 1.1	1.2 $\pm$ 0.3 (No significant increase)	W5Cha stimulates the release of the pro-inflammatory cytokine TNF- $\alpha$ , whereas the scrambled peptide does not, indicating the effect is

sequence-  
dependent.

---

## Signaling Pathway and Experimental Workflow

To provide a clearer understanding of the mechanisms and procedures involved, the following diagrams illustrate the C5aR signaling pathway and a typical experimental workflow for assessing peptide activity.

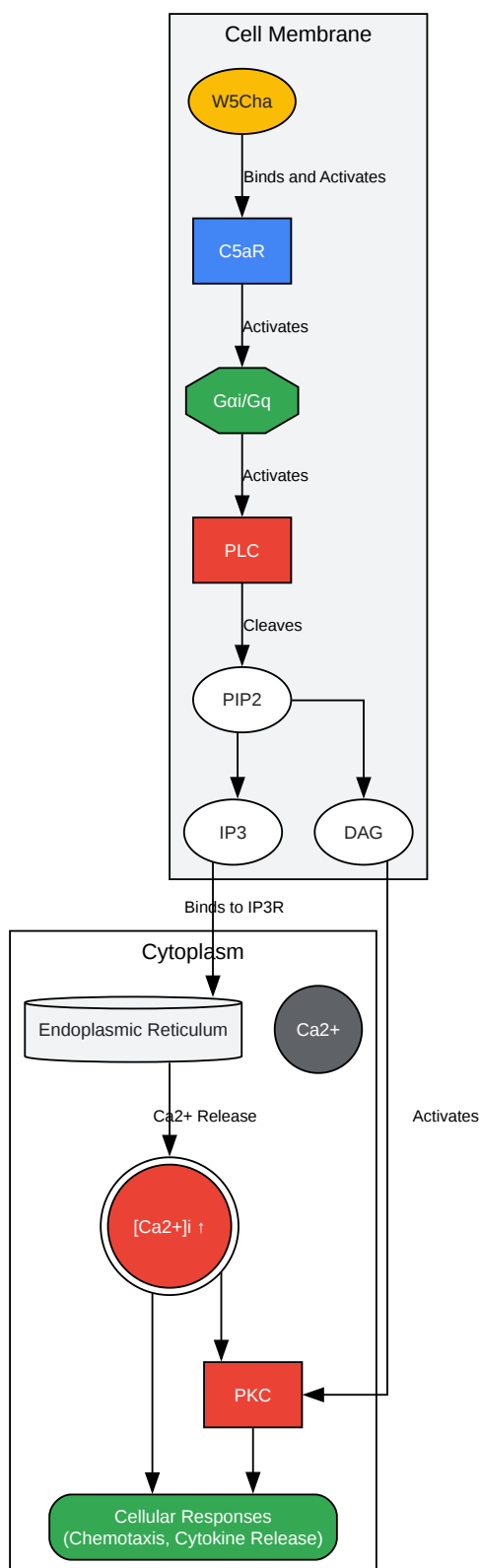

[Click to download full resolution via product page](#)

**Figure 1.** W5Cha-induced C5aR signaling pathway leading to cellular responses.

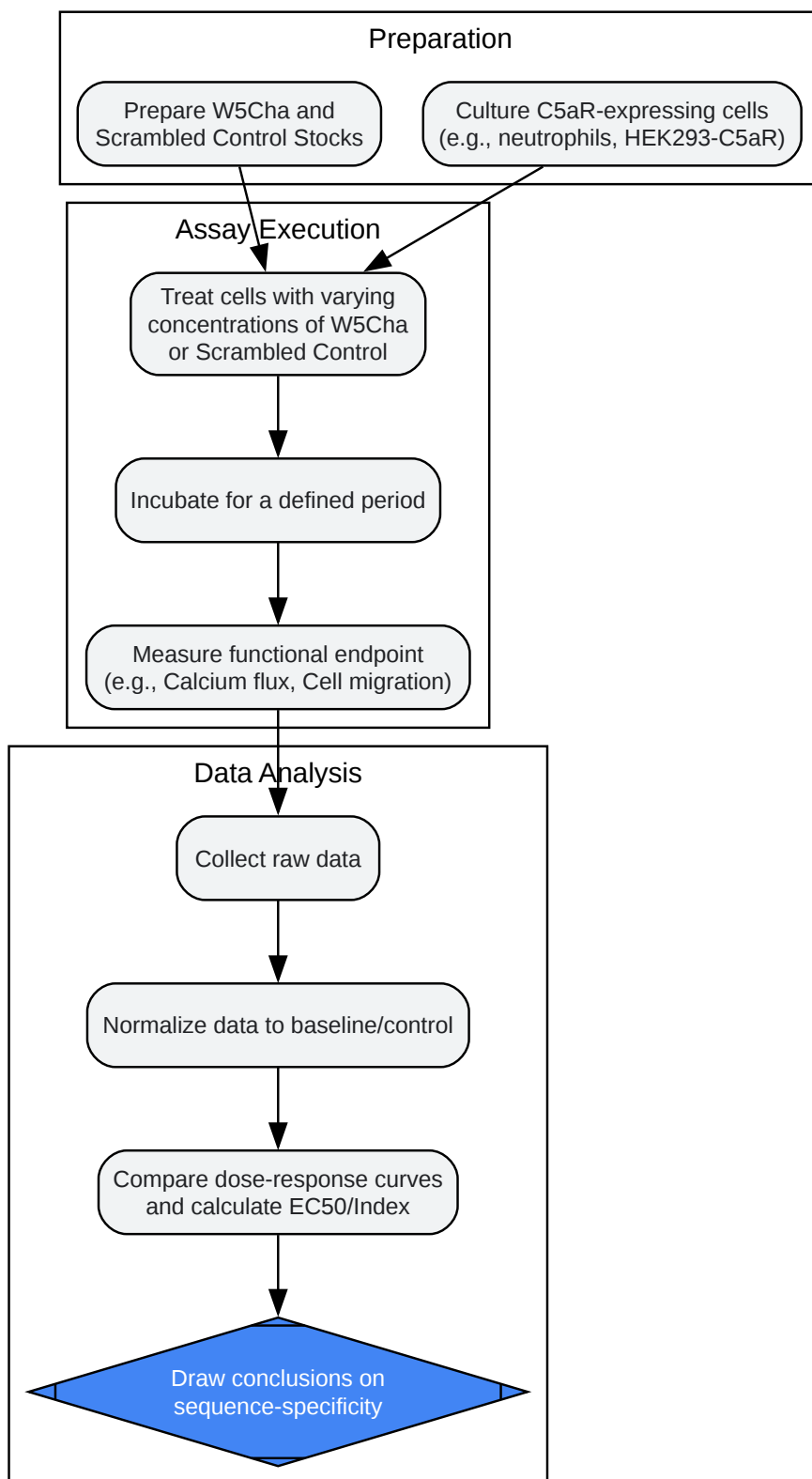

[Click to download full resolution via product page](#)

**Figure 2.** General experimental workflow for comparing W5Cha and its scrambled control.

## Experimental Protocols

The following are detailed methodologies for two key experiments used to characterize the activity of W5Cha and its scrambled control.

### Intracellular Calcium Mobilization Assay

This assay measures the increase in intracellular calcium concentration upon C5aR activation.

Materials:

- HEK293 cells stably expressing human C5aR.
- Cell culture medium: DMEM with 10% FBS, 1% Penicillin-Streptomycin.
- Assay Buffer: Hanks' Balanced Salt Solution (HBSS) with 20 mM HEPES.
- Calcium-sensitive fluorescent dye (e.g., Fluo-4 AM).
- Pluronic F-127.
- W5Cha and Scrambled W5Cha peptides.
- 96-well black, clear-bottom microplates.
- Kinetic fluorescence plate reader (e.g., FLIPR, FlexStation).

Procedure:

- **Cell Plating:** Seed the C5aR-expressing HEK293 cells into 96-well plates at a density that will yield a confluent monolayer on the day of the assay. Incubate overnight.
- **Dye Loading:** Prepare a dye loading solution containing Fluo-4 AM and Pluronic F-127 in Assay Buffer. Remove the culture medium from the cells, wash once with Assay Buffer, and add the dye loading solution to each well. Incubate in the dark at 37°C for 45-60 minutes.
- **Peptide Preparation:** During dye loading, prepare serial dilutions of W5Cha and the scrambled control in Assay Buffer at a concentration 5 times the final desired concentration in a separate 96-well plate.

- **Measurement of Calcium Flux:** Place both the cell plate and the peptide plate into the fluorescence plate reader. Program the instrument to record a baseline fluorescence reading for 15-30 seconds. The instrument will then automatically add the peptides from the peptide plate to the cell plate. Continue recording fluorescence intensity for an additional 2-3 minutes to capture the calcium transient.
- **Data Analysis:** The change in fluorescence is proportional to the change in intracellular calcium. Determine the peak fluorescence response for each concentration and plot the dose-response curves. Calculate the EC50 values for W5Cha and the scrambled control.

## Neutrophil Chemotaxis Assay

This assay quantifies the directed migration of neutrophils towards a chemoattractant.

Materials:

- Freshly isolated human neutrophils.
- Chemotaxis chambers (e.g., Boyden chambers with 3-5  $\mu\text{m}$  pore size filters).
- Assay Medium: RPMI 1640 with 0.5% BSA.
- W5Cha and Scrambled W5Cha peptides.
- Calcein AM (for cell labeling and quantification).
- Fluorescence plate reader.

Procedure:

- **Neutrophil Isolation:** Isolate neutrophils from fresh human blood using density gradient centrifugation (e.g., Ficoll-Paque).
- **Cell Labeling:** Resuspend the isolated neutrophils in Assay Medium and label with Calcein AM according to the manufacturer's protocol. Wash the cells to remove excess dye and resuspend at a final concentration of  $1 \times 10^6$  cells/mL.

- **Assay Setup:** Add different concentrations of W5Cha or the scrambled control to the lower wells of the chemotaxis chamber. Place the porous filter membrane over the lower wells.
- **Cell Migration:** Add the Calcein AM-labeled neutrophil suspension to the upper wells of the chamber. Incubate the plate at 37°C in a 5% CO<sub>2</sub> incubator for 60-90 minutes to allow for cell migration.
- **Quantification:** After incubation, carefully remove the non-migrated cells from the top of the filter. Measure the fluorescence of the migrated cells on the underside of the filter or in the lower chamber using a fluorescence plate reader.
- **Data Analysis:** Calculate the chemotactic index by dividing the fluorescence reading of the sample by the fluorescence reading of the negative control (Assay Medium alone). Plot the chemotactic index against the peptide concentration.

## Conclusion

The use of a scrambled peptide control is fundamental to rigorously validate the sequence-specific activity of a bioactive peptide like W5Cha. The comparative data and protocols provided in this guide are intended to equip researchers with the necessary tools to design and execute well-controlled experiments. By demonstrating that the scrambled control is inactive in relevant functional assays, researchers can confidently attribute the observed biological effects to the specific amino acid sequence of W5Cha, a critical step in the development and characterization of peptide-based therapeutics.

- **To cite this document:** BenchChem. [Scrambled Peptide Control for W5Cha Experiments: A Comparative Guide]. BenchChem, [2026]. [Online PDF]. Available at: [\[https://www.benchchem.com/product/b15608044/docs#scrambled-peptide-control-for-w5cha-experiments-a-comparative-guide\]](https://www.benchchem.com/product/b15608044/docs#scrambled-peptide-control-for-w5cha-experiments-a-comparative-guide)

---

### Disclaimer & Data Validity:

The information provided in this document is for Research Use Only (RUO) and is strictly not intended for diagnostic or therapeutic procedures. While BenchChem strives to provide accurate protocols, we make no warranties, express or implied, regarding the fitness of this product for every specific experimental setup.

**Technical Support:** The protocols provided are for reference purposes. Unsure if this reagent suits your experiment?

**Need Industrial/Bulk Grade?** [Request Custom Synthesis Quote](#)

## BenchChem

Our mission is to be the trusted global source of essential and advanced chemicals, empowering scientists and researchers to drive progress in science and industry.

### Contact

Address: 3281 E Guasti Rd  
Ontario, CA 91761, United States  
Phone: (601) 213-4426  
Email: [info@benchchem.com](mailto:info@benchchem.com)

[Contact our Ph.D. Support Team for a compatibility check](#)