

PD 168368: Application Notes and Protocols for In Vitro Cell Culture Studies

Author: BenchChem Technical Support Team. **Date:** April 2026

Compound of Interest

Compound Name: PD 168368

Cat. No.: B15608582

[Get Quote](#)

For Researchers, Scientists, and Drug Development Professionals

Abstract

PD 168368 is a potent and selective antagonist of the neuromedin B receptor (NMB-R), also known as the BB1 receptor.[1][2] It has been utilized in in vitro studies to investigate the role of NMB-R signaling in various cellular processes, particularly in cancer biology.[3] This document provides detailed application notes and protocols for the use of **PD 168368** in cell culture experiments, including its effects on cell signaling, migration, and proliferation.

Mechanism of Action

PD 168368 is a competitive antagonist of the NMB-R, with a high affinity for NMB receptors across different species.[1] It inhibits the binding of neuromedin B (NMB) to its receptor, thereby blocking downstream signaling pathways.[1] Studies have shown that **PD 168368** can suppress the activation of key signaling cascades, including the mTOR/p70S6K/4EBP1 and AKT/GSK-3 β pathways.[3] Additionally, it has been observed to inhibit NMB-induced transactivation of the epidermal growth factor receptor (EGFR).[4] While primarily an NMB-R antagonist, **PD 168368** has also been identified as a mixed agonist for formyl-peptide receptors (FPR1/FPR2/FPR3).[3][5]

Quantitative Data Summary

The following tables summarize the reported in vitro activities of **PD 168368**.

Table 1: Receptor Binding Affinity and Antagonist Potency

| Receptor/Assay | Cell Line/System | Species | Parameter | Value (nM) | Reference |
|--|------------------|-------------------|-----------|--------------------------------------|-----------|
| NMB-R | Various | Human, Mouse, Rat | Ki | 15 - 45 | [1] |
| NMB-R | CHO cells | Human | Ki | 0.15 | [6] |
| NMB-R | C6 cells | Rat | IC50 | 40 | [7] |
| NMB-R | NCI-H1299 cells | Human | IC50 | 47 | [4] |
| Gastrin-Releasing Peptide Receptor (GRP-R) | Various | Human, Mouse, Rat | Ki | 30-60 fold lower affinity than NMB-R | [1] |
| Bombesin Receptor Subtype 3 (BRS-3) | Various | Human, Mouse, Rat | Ki | >300 fold lower affinity than NMB-R | [1] |

Table 2: Functional Antagonist and Agonist Activity

| Target | Cell Type | Activity | Parameter | Value (nM) | Reference |
|--------|-------------------|------------|-----------|------------|-----------|
| NMB-R | - | Antagonist | IC50 | 96 | [3][8] |
| GRP-R | - | Antagonist | IC50 | 3500 | [3][8] |
| FPR1 | Human Neutrophils | Agonist | EC50 | 0.57 | [3][8] |
| FPR2 | Human Neutrophils | Agonist | EC50 | 0.24 | [3][8] |
| FPR3 | Human Neutrophils | Agonist | EC50 | 2.7 | [3][8] |

Experimental Protocols

Cell Culture and Treatment

A variety of cancer cell lines have been used in studies with **PD 168368**, including human breast cancer (MDA-MB-231), rat glioblastoma (C6), and human lung cancer (NCI-H1299) cells.[3][7][9]

Materials:

- Cell line of interest (e.g., MDA-MB-231)
- Complete cell culture medium (e.g., DMEM supplemented with 10% FBS and 1% penicillin-streptomycin)
- **PD 168368** stock solution (dissolved in DMSO)
- Phosphate-buffered saline (PBS)
- Cell culture flasks/plates

Protocol:

- Culture cells in a humidified incubator at 37°C with 5% CO₂.

- Seed cells into appropriate culture vessels (e.g., 6-well plates, 96-well plates) and allow them to adhere overnight.
- Prepare working concentrations of **PD 168368** by diluting the stock solution in a complete culture medium. Note: It is recommended to use hydroxypropyl- β -cyclodextrin as a vehicle to improve solubility and potency.[1]
- Remove the culture medium from the cells and wash once with PBS.
- Add the medium containing the desired concentration of **PD 168368** (e.g., 5-10 μ M) or vehicle control to the cells.[3]
- Incubate for the desired period (e.g., 24, 48, or 72 hours) before proceeding with downstream assays.

Western Blot Analysis of Signaling Pathways

This protocol is designed to assess the effect of **PD 168368** on the phosphorylation status of key signaling proteins.

Materials:

- Treated and untreated cell lysates
- Lysis buffer (e.g., RIPA buffer with protease and phosphatase inhibitors)
- BCA protein assay kit
- SDS-PAGE gels
- Transfer buffer
- PVDF membrane
- Blocking buffer (e.g., 5% non-fat milk or BSA in TBST)
- Primary antibodies (e.g., anti-phospho-mTOR, anti-phospho-AKT, anti-phospho-p70S6K, anti-phospho-4EBP1, anti-phospho-GSK-3 β , and total protein controls)

- HRP-conjugated secondary antibody
- Chemiluminescent substrate
- Imaging system

Protocol:

- After treatment with **PD 168368**, wash cells with ice-cold PBS and lyse with lysis buffer.
- Clarify lysates by centrifugation and determine protein concentration using a BCA assay.
- Denature protein samples by boiling in Laemmli buffer.
- Separate proteins by SDS-PAGE and transfer to a PVDF membrane.
- Block the membrane with blocking buffer for 1 hour at room temperature.
- Incubate the membrane with primary antibodies overnight at 4°C.
- Wash the membrane with TBST and incubate with HRP-conjugated secondary antibody for 1 hour at room temperature.
- Wash the membrane again and detect the signal using a chemiluminescent substrate and an imaging system.

Cell Migration and Invasion Assays

The Boyden chamber assay is a common method to evaluate the effect of **PD 168368** on cell migration and invasion.^[3]

Materials:

- Boyden chamber inserts (8 µm pore size)
- 24-well plates
- Serum-free medium

- Complete medium (as a chemoattractant)
- Matrigel (for invasion assay)
- Cotton swabs
- Methanol
- Crystal violet stain

Protocol:

- For the invasion assay, coat the Boyden chamber inserts with Matrigel. For the migration assay, no coating is needed.
- Resuspend cells in a serum-free medium containing **PD 168368** or vehicle control.
- Add the cell suspension to the upper chamber of the insert.
- Add a complete medium to the lower chamber as a chemoattractant.
- Incubate for a sufficient time to allow for migration/invasion (e.g., 24 hours).
- Remove non-migrated/invaded cells from the upper surface of the insert with a cotton swab.
- Fix the cells on the lower surface of the insert with methanol.
- Stain the cells with crystal violet.
- Count the number of migrated/invaded cells under a microscope.

Visualizations

Signaling Pathway Diagram

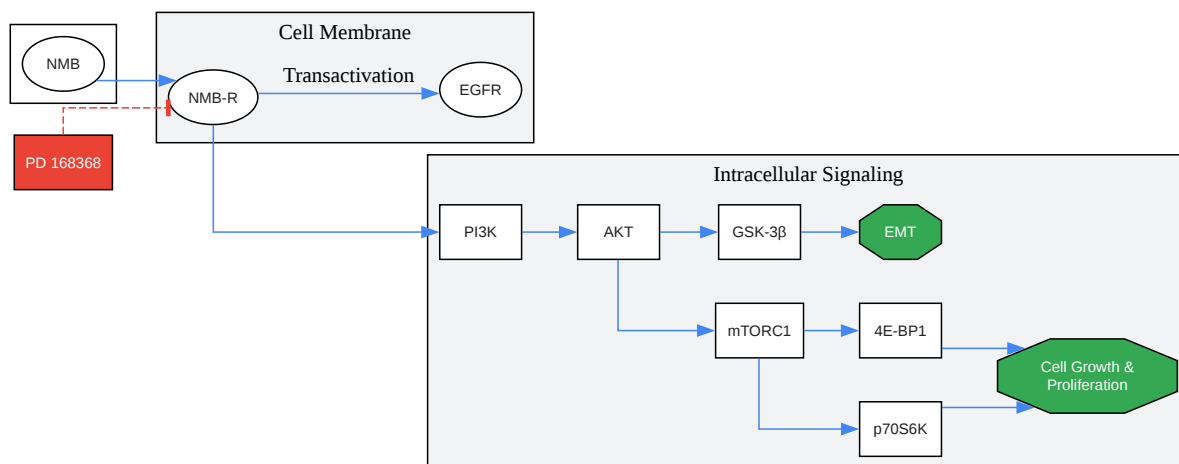

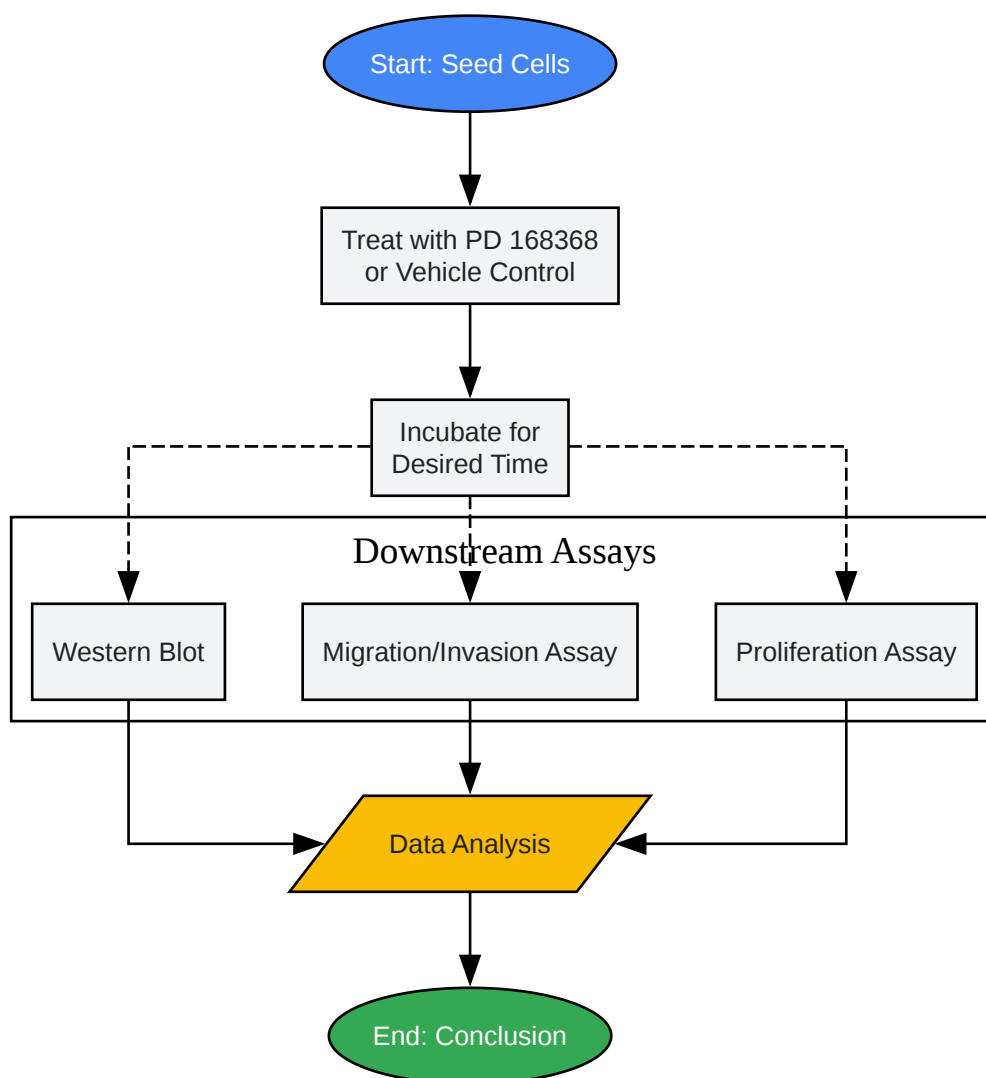

[Click to download full resolution via product page](#)

Need Custom Synthesis?

BenchChem offers custom synthesis for rare earth carbides and specific isotopic labeling.

Email: info@benchchem.com or [Request Quote Online](#).

References

- 1. [Comparative pharmacology of the nonpeptide neuromedin B receptor antagonist PD 168368 - PubMed \[pubmed.ncbi.nlm.nih.gov\]](#)

- [2. International Union of Pharmacology. LXVIII. Mammalian Bombesin Receptors: Nomenclature, distribution, pharmacology, signaling and functions in normal and disease states - PMC \[pmc.ncbi.nlm.nih.gov\]](#)
- [3. medchemexpress.com \[medchemexpress.com\]](#)
- [4. Neuromedin B receptors regulate EGF receptor tyrosine phosphorylation in lung cancer cells - PMC \[pmc.ncbi.nlm.nih.gov\]](#)
- [5. Gastrin-releasing peptide/neuromedin B receptor antagonists PD176252, PD168368, and related analogs are potent agonists of human formyl-peptide receptors - PubMed \[pubmed.ncbi.nlm.nih.gov\]](#)
- [6. PD 168368 | Ligand Activity Charts | IUPHAR/BPS Guide to PHARMACOLOGY \[guidetopharmacology.org\]](#)
- [7. researchgate.net \[researchgate.net\]](#)
- [8. abmole.com \[abmole.com\]](#)
- [9. Gastrin-Releasing Peptide/Neuromedin B Receptor Antagonists PD176252, PD168368, and Related Analogs Are Potent Agonists of Human Formyl-Peptide Receptors - PMC \[pmc.ncbi.nlm.nih.gov\]](#)
- [To cite this document: BenchChem. \[PD 168368: Application Notes and Protocols for In Vitro Cell Culture Studies\]. BenchChem, \[2026\]. \[Online PDF\]. Available at: \[https://www.benchchem.com/product/b15608582/docs#pd-168368-application-notes-and-protocols-for-in-vitro-cell-culture-studies\]](#)

Disclaimer & Data Validity:

The information provided in this document is for Research Use Only (RUO) and is strictly not intended for diagnostic or therapeutic procedures. While BenchChem strives to provide accurate protocols, we make no warranties, express or implied, regarding the fitness of this product for every specific experimental setup.

Technical Support: The protocols provided are for reference purposes. Unsure if this reagent suits your experiment?

Need Industrial/Bulk Grade? [Request Custom Synthesis Quote](#)

BenchChem

Our mission is to be the trusted global source of essential and advanced chemicals, empowering scientists and researchers to drive progress in science and industry.

Contact

Address: 3281 E Guasti Rd

Ontario, CA 91761, United States

Phone: (601) 213-4426

Email: info@benchchem.com

[Contact our Ph.D. Support Team for a compatibility check](#)