

# On-Target Effects of PD 168368: A Comparative Guide to Validation Using siRNA

**Author:** BenchChem Technical Support Team. **Date:** April 2026

## Compound of Interest

Compound Name: PD 168368

Cat. No.: B15608582

[Get Quote](#)

For Researchers, Scientists, and Drug Development Professionals

This guide provides a comprehensive comparison of pharmacological inhibition and genetic knockdown methods for validating the on-target effects of **PD 168368**, a selective antagonist of the Neuromedin B Receptor (NMBR). The focus is on the indirect effect of NMBR inhibition on the Epidermal Growth Factor Receptor (EGFR) signaling pathway, a key pathway in cell proliferation and survival.

## Introduction

**PD 168368** is a potent and selective non-peptide antagonist of the Neuromedin B Receptor (NMBR), a G protein-coupled receptor.[1] While not a direct inhibitor of the Epidermal Growth Factor Receptor (EGFR), its on-target effect on NMBR can indirectly modulate EGFR signaling. Activation of NMBR has been shown to cause the transactivation of EGFR, leading to the phosphorylation and activation of downstream signaling cascades.[2] Therefore, confirming the on-target effects of **PD 168368** involves demonstrating that its observed biological effects are a direct consequence of NMBR antagonism, which can be validated by comparing its effects to those of NMBR gene silencing using small interfering RNA (siRNA).

This guide compares the use of **PD 168368** with NMBR siRNA in downregulating NMBR-mediated EGFR activation. While direct quantitative comparisons in the literature are limited, this guide synthesizes available data to provide a framework for experimental design and interpretation.

## Comparison of PD 168368 and NMBR siRNA

Feature	PD 168368 (Pharmacological Inhibition)	NMBR siRNA (Genetic Knockdown)
Mechanism of Action	Competitively binds to and blocks the Neuromedin B Receptor, preventing its activation by the endogenous ligand, Neuromedin B.[1]	Post-transcriptionally silences the NMBR gene, leading to the degradation of NMBR mRNA and a subsequent reduction in NMBR protein expression.
Specificity	Highly selective for NMBR over the Gastrin-Releasing Peptide Receptor (GRPR).[1] However, potential for off-target effects on other receptors or signaling molecules should be considered.	Highly specific to the NMBR mRNA sequence. Off-target effects on other genes are possible but can be minimized through careful siRNA design and validation.
Mode of Action	Reversible (in most cases)	Transient, with the duration of knockdown dependent on cell division and siRNA stability.
Application	In vitro and in vivo studies to investigate the acute effects of NMBR blockade.	Primarily in vitro studies for target validation and mechanistic studies. In vivo applications are possible but more complex.
Ease of Use	Relatively simple to apply to cell cultures or administer in animal models.	Requires transfection optimization for efficient delivery into cells.
Confirmation of On-Target Effect	Comparison with a structurally distinct NMBR antagonist or validation with genetic methods like siRNA.	Comparison with a non-targeting control siRNA and rescue experiments (re-expression of NMBR).

## Experimental Data

While direct head-to-head quantitative data comparing **PD 168368** and NMBR siRNA on EGFR phosphorylation is not readily available in published literature, the expected outcomes can be inferred from independent studies.

Table 1: Expected Effects on NMBR and Downstream EGFR Signaling

Treatment	Target	Expected Effect on NMBR	Expected Effect on NMB-induced EGFR Phosphorylation
PD 168368	NMBR Protein	Inhibition of ligand binding and receptor activation	Significant reduction
NMBR siRNA	NMBR mRNA	Degradation of mRNA, leading to reduced protein expression	Significant reduction
Control (e.g., vehicle, non-targeting siRNA)	N/A	No effect	No effect

Note: The magnitude of the effect will depend on experimental conditions such as cell type, concentration of **PD 168368**, siRNA knockdown efficiency, and stimulation with Neuromedin B.

## Experimental Protocols

### Protocol 1: NMBR siRNA Transfection and Western Blot for Phosphorylated EGFR

Objective: To determine the efficiency of NMBR knockdown by siRNA and its effect on Neuromedin B-induced EGFR phosphorylation.

Materials:

- Human cancer cell line expressing NMBR and EGFR (e.g., NCI-H1299)

- NMBR-specific siRNA and non-targeting control siRNA
- Transfection reagent (e.g., Lipofectamine™ RNAiMAX)
- Opti-MEM™ Reduced Serum Medium
- Complete cell culture medium
- Neuromedin B (NMB) peptide
- Lysis buffer (e.g., RIPA buffer with protease and phosphatase inhibitors)
- BCA Protein Assay Kit
- SDS-PAGE gels and running buffer
- Transfer buffer and PVDF membrane
- Blocking buffer (e.g., 5% BSA in TBST)
- Primary antibodies: anti-NMBR, anti-phospho-EGFR (Tyr1173), anti-total EGFR, anti-β-actin
- HRP-conjugated secondary antibody
- Chemiluminescent substrate

#### Procedure:

- Cell Seeding: Seed cells in 6-well plates to be 70-80% confluent at the time of transfection.
- siRNA Transfection:
  - Prepare siRNA-lipid complexes according to the transfection reagent manufacturer's protocol.[3]
  - Incubate cells with the transfection complexes for 4-6 hours.
  - Replace the transfection medium with fresh complete medium and incubate for 48-72 hours to allow for NMBR knockdown.

- Cell Stimulation and Lysis:
  - Starve cells in serum-free medium for 4-6 hours.
  - Treat cells with NMB (e.g., 100 nM) for a short period (e.g., 5-15 minutes) to induce EGFR phosphorylation.
  - Wash cells with ice-cold PBS and lyse with lysis buffer.
- Western Blot Analysis:
  - Determine protein concentration using the BCA assay.
  - Separate equal amounts of protein by SDS-PAGE and transfer to a PVDF membrane.
  - Block the membrane and incubate with primary antibodies overnight at 4°C.
  - Wash the membrane and incubate with HRP-conjugated secondary antibody.
  - Detect the signal using a chemiluminescent substrate and an imaging system.
  - Quantify band intensities and normalize phospho-EGFR to total EGFR and NMBR to  $\beta$ -actin.

## Protocol 2: Pharmacological Inhibition with PD 168368 and Western Blot for Phosphorylated EGFR

Objective: To assess the inhibitory effect of **PD 168368** on Neuromedin B-induced EGFR phosphorylation.

Procedure:

- Cell Seeding and Starvation: Follow the same procedure as in Protocol 1.
- Inhibitor Treatment and Stimulation:
  - Pre-incubate cells with varying concentrations of **PD 168368** (or vehicle control) for 1-2 hours.

- Stimulate cells with NMB (e.g., 100 nM) for 5-15 minutes in the continued presence of **PD 168368**.
- Cell Lysis and Western Blot Analysis: Follow the same procedure as in Protocol 1 to analyze the levels of phosphorylated and total EGFR.

## Visualization of Pathways and Workflows

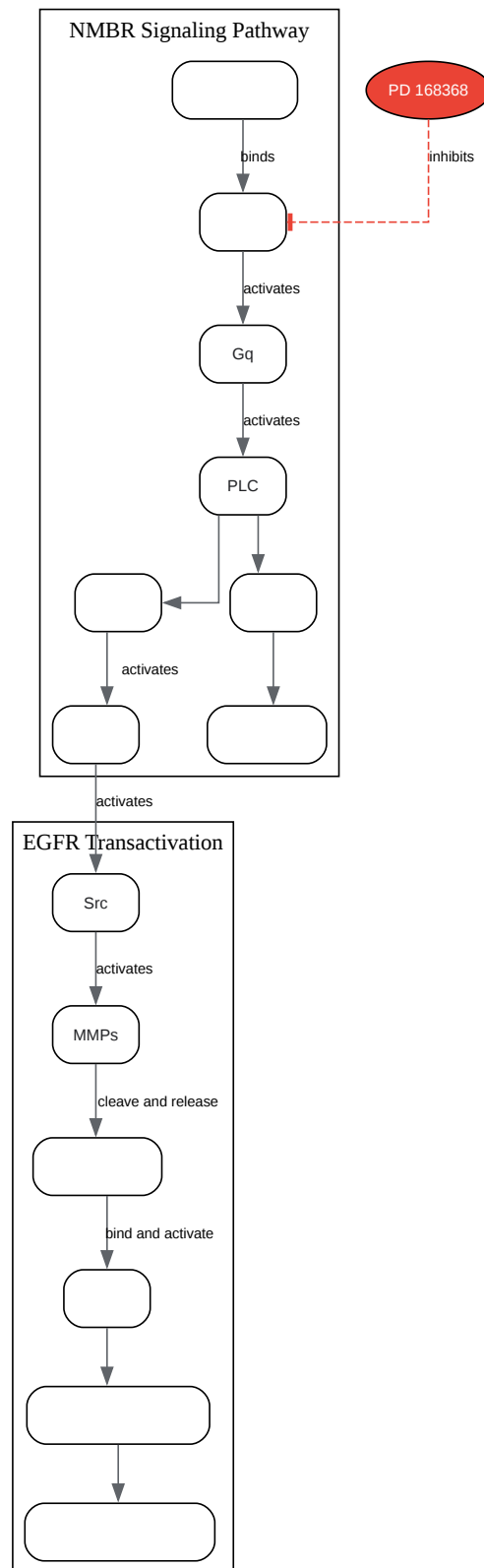

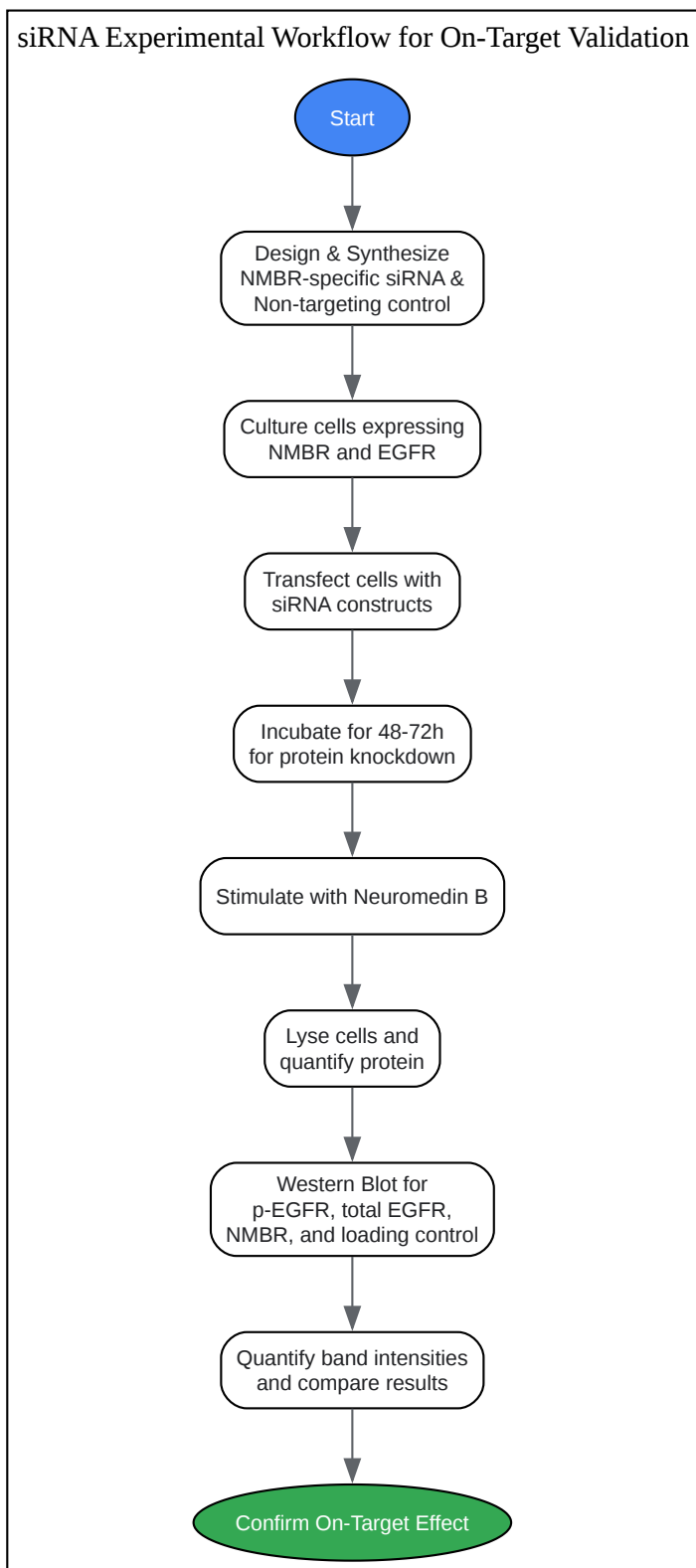

[Click to download full resolution via product page](#)

### Need Custom Synthesis?

BenchChem offers custom synthesis for rare earth carbides and specific isotopic labeling.

Email: [info@benchchem.com](mailto:info@benchchem.com) or [Request Quote Online](#).

## References

- 1. Comparative pharmacology of the nonpeptide neuromedin B receptor antagonist PD 168368 - PubMed [[pubmed.ncbi.nlm.nih.gov](https://pubmed.ncbi.nlm.nih.gov)]
- 2. [medchemexpress.com](https://medchemexpress.com) [[medchemexpress.com](https://medchemexpress.com)]
- 3. [datasheets.scbt.com](https://datasheets.scbt.com) [[datasheets.scbt.com](https://datasheets.scbt.com)]
- To cite this document: BenchChem. [On-Target Effects of PD 168368: A Comparative Guide to Validation Using siRNA]. BenchChem, [2026]. [Online PDF]. Available at: [<https://www.benchchem.com/product/b15608582/docs#on-target-effects-of-pd-168368-a-comparative-guide-to-validation-using-sirna>]

---

### Disclaimer & Data Validity:

The information provided in this document is for Research Use Only (RUO) and is strictly not intended for diagnostic or therapeutic procedures. While BenchChem strives to provide accurate protocols, we make no warranties, express or implied, regarding the fitness of this product for every specific experimental setup.

**Technical Support:** The protocols provided are for reference purposes. Unsure if this reagent suits your experiment?

**Need Industrial/Bulk Grade?** [Request Custom Synthesis Quote](#)

# BenchChem

Our mission is to be the trusted global source of essential and advanced chemicals, empowering scientists and researchers to drive progress in science and industry.

## Contact

Address: 3281 E Guasti Rd

Ontario, CA 91761, United States

Phone: (601) 213-4426

Email: [info@benchchem.com](mailto:info@benchchem.com)

[Contact our Ph.D. Support Team for a compatibility check](#)