

# MLi-2 Application Notes: Solubility, Protocols, and Pathway Insights

**Author:** BenchChem Technical Support Team. **Date:** April 2026

## Compound of Interest

Compound Name: MLi-2  
Cat. No.: B15608315

[Get Quote](#)

For Researchers, Scientists, and Drug Development Professionals

These application notes provide a comprehensive guide to the use of **MLi-2**, a potent and selective inhibitor of Leucine-Rich Repeat Kinase 2 (LRRK2). This document includes detailed information on the solubility of **MLi-2** in various solvents, experimental protocols for its use in cellular and in vivo models, and an overview of the LRRK2 signaling pathway.

## MLi-2: A Powerful Tool for LRRK2 Research

**MLi-2** is a highly selective and potent inhibitor of LRRK2, a kinase implicated in both familial and sporadic cases of Parkinson's disease.[1][2] Its ability to penetrate the central nervous system makes it a valuable tool for studying the therapeutic potential and safety of LRRK2 kinase inhibition in relevant disease models.[1] **MLi-2** has demonstrated exceptional potency in inhibiting LRRK2 in various assays, including cell-free, cell-based, and radioligand-binding assays.[1][3][4]

## Solubility of MLi-2

**MLi-2** exhibits high solubility in dimethyl sulfoxide (DMSO) but has poor aqueous solubility.[5] For in vitro and in vivo experiments, it is crucial to select the appropriate solvent system to

ensure complete dissolution and accurate dosing.

### Table 1: MLi-2 Solubility in Common Laboratory Solvents

Solvent	Concentration	Notes	Reference
DMSO	100 mM	---	[3]
DMSO	76 mg/mL (~200 mM)	Hygroscopic DMSO can impact solubility; use fresh DMSO.	[4][6]
DMSO	50 mg/mL (~132 mM)	Ultrasonic treatment may be needed.	[7]
DMSO	15 mg/mL	---	[8]
Water	Insoluble	---	[6]
Ethanol	Insoluble	---	[6]

### Table 2: Recommended Solvent Formulations for In Vivo Studies

Formulation Components (v/v)	Achieved Concentration	Solution Appearance	Reference
10% DMSO, 90% Corn Oil	≥ 2 mg/mL	Clear solution	[7]
10% DMSO, 40% PEG300, 5% Tween-80, 45% Saline	≥ 2 mg/mL	Clear solution	[7]
5% DMSO, 95% (20% SBE-β-CD in Saline)	≥ 2.87 mg/mL	Clear solution	[7]
5% DMSO, 40% PEG300, 5% Tween-80, 50% Saline	2.87 mg/mL	Suspended solution; requires sonication	[7]

## LRRK2 Signaling Pathway and MLI-2 Inhibition

LRRK2 is a large, multi-domain protein with both kinase and GTPase activity.[9][10] Mutations in the LRRK2 gene are a significant genetic contributor to Parkinson's disease.[9] The kinase activity of LRRK2 is a key focus for therapeutic intervention, and **MLi-2** acts as a specific inhibitor of this function.[1][3] LRRK2 is involved in several cellular processes, including vesicle trafficking and autophagy, and interacts with pathways such as the mitogen-activated protein kinase (MAPK) pathway.[3][11] A primary mechanism for assessing LRRK2 activity and its inhibition by compounds like **MLi-2** is through the measurement of autophosphorylation at serine 935 (pS935) or the phosphorylation of its substrate, Rab10.[1][12][13]

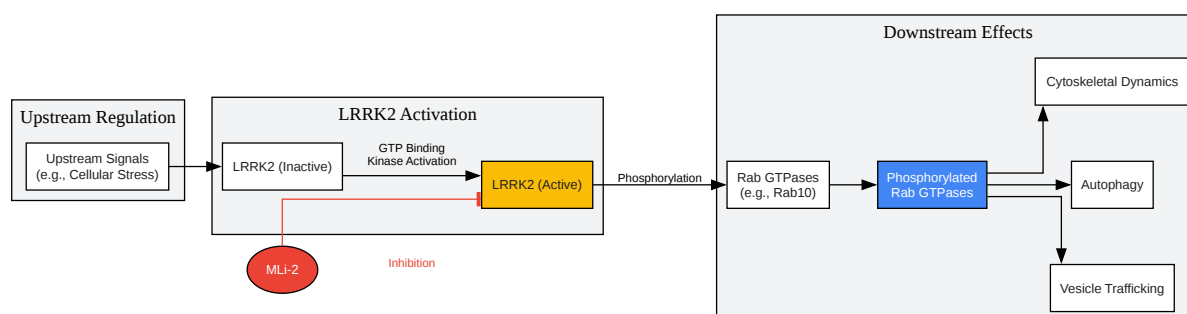

[Click to download full resolution via product page](#)

Caption: LRRK2 signaling pathway and the inhibitory action of **MLi-2**.

## Experimental Protocols

### Protocol 1: Preparation of MLI-2 Stock Solution

Objective: To prepare a high-concentration stock solution of **MLi-2** for subsequent dilution in cell culture media or other aqueous buffers.

#### Materials:

- **MLi-2** powder
- Anhydrous Dimethyl Sulfoxide (DMSO)
- Sterile microcentrifuge tubes or vials
- Vortex mixer
- Sonicator (optional)

#### Procedure:

- Aseptically weigh the desired amount of **MLi-2** powder.
- Add the appropriate volume of anhydrous DMSO to achieve the desired stock concentration (e.g., 50-100 mM). It is recommended to use fresh, high-purity DMSO as it is hygroscopic and absorbed water can reduce the solubility of **MLi-2**.[\[4\]](#)
- Vortex the solution vigorously until the **MLi-2** is completely dissolved. If necessary, use a sonicator to aid dissolution.[\[7\]](#)
- Store the stock solution at -20°C or -80°C for long-term stability.[\[7\]](#) When stored at -20°C, use within one year; at -80°C, use within two years.[\[7\]](#)

## Protocol 2: In Vitro LRRK2 Kinase Inhibition Assay in a Cellular Context

Objective: To assess the potency of **MLi-2** in inhibiting LRRK2 kinase activity in a cellular model by measuring the phosphorylation of a LRRK2 substrate.

#### Materials:

- HEK293 or SH-SY5Y cells stably overexpressing LRRK2[\[14\]](#)
- Complete cell culture medium (e.g., DMEM with 10% FBS)

- **MLi-2** stock solution (from Protocol 1)
- Phosphate-buffered saline (PBS)
- Lysis buffer (e.g., RIPA buffer with protease and phosphatase inhibitors)
- Primary antibodies: anti-pS935-LRRK2, anti-total LRRK2, anti-pT73-Rab10, anti-total Rab10
- HRP-conjugated secondary antibodies
- Western blot reagents and equipment

Procedure:

- Seed cells in a multi-well plate and allow them to adhere and grow to 70-80% confluency.[\[12\]](#)  
[\[13\]](#)
- Prepare serial dilutions of **MLi-2** in complete cell culture medium from the DMSO stock solution. Ensure the final DMSO concentration is consistent across all wells and does not exceed a level toxic to the cells (typically  $\leq 0.1\%$ ).
- Treat the cells with varying concentrations of **MLi-2** (or vehicle control) for a specified time (e.g., 2 hours).[\[15\]](#)
- After treatment, wash the cells with ice-cold PBS and lyse them.
- Determine the protein concentration of the lysates.
- Perform SDS-PAGE and western blotting to analyze the phosphorylation status of LRRK2 (pS935) or Rab10 (pT73) relative to their total protein levels.
- Quantify the band intensities to determine the  $IC_{50}$  value of **MLi-2**.

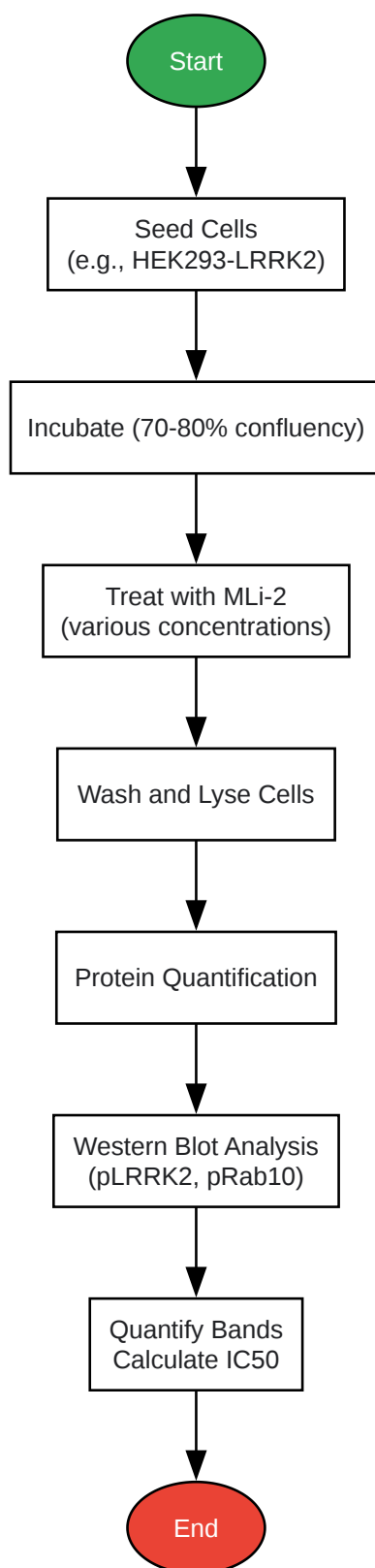

[Click to download full resolution via product page](#)

Caption: Workflow for a cellular LRRK2 kinase inhibition assay.

## Protocol 3: In Vivo Administration of MLI-2 in a Mouse Model

Objective: To evaluate the effect of **MLi-2** on LRRK2 activity in a living organism.

Materials:

- **MLi-2**
- Vehicle formulation (see Table 2)
- Mice (e.g., C57BL/6J or a Parkinson's disease model)[14]
- Gavage needles or injection syringes
- Tissue homogenization equipment
- Western blot reagents as in Protocol 2

Procedure:

- Prepare the **MLi-2** formulation for in vivo administration as described in Table 2. Ensure the compound is fully dissolved or homogeneously suspended.
- Administer **MLi-2** to the mice via the desired route (e.g., oral gavage or intraperitoneal injection).[1][14] Dosing will depend on the specific study design. For example, mice have been injected four times over 30 hours with 10 mg/kg of **MLi-2**. [14]
- At the end of the treatment period, sacrifice the animals and harvest tissues of interest (e.g., brain, lung, kidney).[14]
- Homogenize the tissues and prepare lysates.
- Perform western blot analysis as described in Protocol 2 to assess the levels of pS935-LRRK2 and total LRRK2 in the tissue extracts.[14]

Note on In Vivo Studies: Treatment with **MLi-2** has been associated with morphological changes in the lungs of mice, specifically enlarged type II pneumocytes.[1] Researchers should

be aware of this potential effect and monitor for it in their studies.

These application notes are intended to serve as a guide. Researchers should optimize protocols for their specific experimental systems and objectives.

### *Need Custom Synthesis?*

*BenchChem offers custom synthesis for rare earth carbides and specific isotopic labeling.*

*Email: [info@benchchem.com](mailto:info@benchchem.com) or [Request Quote Online](#).*

## References

- [1. MLI-2, a Potent, Selective, and Centrally Active Compound for Exploring the Therapeutic Potential and Safety of LRRK2 Kinase Inhibition - PubMed \[pubmed.ncbi.nlm.nih.gov\]](#)
- [2. Inhibition of Parkinson's disease-related LRRK2 by type I and type II kinase inhibitors: Activity and structures - PMC \[pmc.ncbi.nlm.nih.gov\]](#)
- [3. MLI-2, LRRK2 inhibitor \(CAS 1627091-47-7\) | Abcam \[abcam.com\]](#)
- [4. selleckchem.com \[selleckchem.com\]](#)
- [5. researchgate.net \[researchgate.net\]](#)
- [6. selleck.co.jp \[selleck.co.jp\]](#)
- [7. medchemexpress.com \[medchemexpress.com\]](#)
- [8. caymanchem.com \[caymanchem.com\]](#)
- [9. The LRRK2 signalling system - PubMed \[pubmed.ncbi.nlm.nih.gov\]](#)
- [10. Mechanisms of LRRK2-dependent neurodegeneration: role of enzymatic activity and protein aggregation - PMC \[pmc.ncbi.nlm.nih.gov\]](#)
- [11. Frontiers | Interaction of LRRK2 with kinase and GTPase signaling cascades \[frontiersin.org\]](#)
- [12. Measurement of LRRK2 Kinase Activity by Proximity Ligation Assay \[bio-protocol.org\]](#)
- [13. Measurement of LRRK2 Kinase Activity by Proximity Ligation Assay - PMC \[pmc.ncbi.nlm.nih.gov\]](#)
- [14. Pharmacological LRRK2 kinase inhibition induces LRRK2 protein destabilization and proteasomal degradation - PMC \[pmc.ncbi.nlm.nih.gov\]](#)

- [15. Evaluation of Current Methods to Detect Cellular Leucine-Rich Repeat Kinase 2 \(LRRK2\) Kinase Activity - PMC \[pmc.ncbi.nlm.nih.gov\]](#)
- To cite this document: BenchChem. [MLi-2 Application Notes: Solubility, Protocols, and Pathway Insights]. BenchChem, [2026]. [Online PDF]. Available at: [<https://www.benchchem.com/product/b15608315/docs#mli-2-application-notes-solubility-protocols-and-pathway-insights>]

---

**Disclaimer & Data Validity:**

The information provided in this document is for Research Use Only (RUO) and is strictly not intended for diagnostic or therapeutic procedures. While BenchChem strives to provide accurate protocols, we make no warranties, express or implied, regarding the fitness of this product for every specific experimental setup.

**Technical Support:** The protocols provided are for reference purposes. Unsure if this reagent suits your experiment?

**Need Industrial/Bulk Grade?** [Request Custom Synthesis Quote](#)

## BenchChem

Our mission is to be the trusted global source of essential and advanced chemicals, empowering scientists and researchers to drive progress in science and industry.

### Contact

Address: 3281 E Guasti Rd  
Ontario, CA 91761, United States  
Phone: (601) 213-4426  
Email: [info@benchchem.com](mailto:info@benchchem.com)

[Contact our Ph.D. Support Team for a compatibility check](#)