

LM22B-10 for Traumatic Brain Injury Research: A Technical Guide

Author: BenchChem Technical Support Team. **Date:** April 2026

Compound of Interest

Compound Name: LM22B-10
Cat. No.: B15608413

[Get Quote](#)

An In-depth Examination of a Novel TrkB/TrkC Agonist for Neurotrauma Therapeutics

For Researchers, Scientists, and Drug Development Professionals

Abstract

Traumatic Brain Injury (TBI) remains a significant global health challenge, with limited therapeutic options to mitigate its devastating neurological consequences. The neurotrophin signaling pathways, particularly those mediated by Tropomyosin receptor kinase B (TrkB) and C (TrkC), have emerged as promising targets for promoting neuronal survival, neurogenesis, and functional recovery following injury. **LM22B-10**, a small-molecule, blood-brain barrier-permeant co-activator of TrkB and TrkC, has shown considerable potential in preclinical TBI models. This technical guide provides a comprehensive overview of the core research on **LM22B-10** in the context of TBI, summarizing key quantitative data, detailing experimental protocols, and visualizing critical signaling pathways and workflows to facilitate further investigation and drug development efforts in this area.

Introduction to LM22B-10

LM22B-10 is a novel small molecule that uniquely functions as a co-agonist for both TrkB and TrkC neurotrophin receptors.[1][2] Unlike the endogenous ligands, brain-derived neurotrophic factor (BDNF) for TrkB and neurotrophin-3 (NT-3) for TrkC, **LM22B-10** offers the advantage of being blood-brain barrier permeant, allowing for systemic administration.[3] Its dual agonism presents a distinct therapeutic profile compared to more selective Trk receptor activators.[1] Research suggests that **LM22B-10** promotes neuronal growth and differentiation, enhances cell survival, and accelerates neurite outgrowth, in some instances surpassing the effects of BDNF and NT-3.[1][4] These properties make it a compelling candidate for mitigating the multifaceted pathology of TBI.

Mechanism of Action and Signaling Pathways

LM22B-10 exerts its neuroprotective and neuro-restorative effects by binding to and activating TrkB and TrkC receptors.[1] This activation triggers downstream signaling cascades crucial for neuronal function and survival. The primary pathways implicated include the Akt and ERK (extracellular signal-regulated kinase) pathways.[5][6]

Upon binding of **LM22B-10**, the Trk receptors dimerize and autophosphorylate, leading to the recruitment and activation of various intracellular signaling proteins. This cascade ultimately promotes gene transcription and protein synthesis that underpin processes like cell survival, synaptic plasticity, and neurite outgrowth.[5]

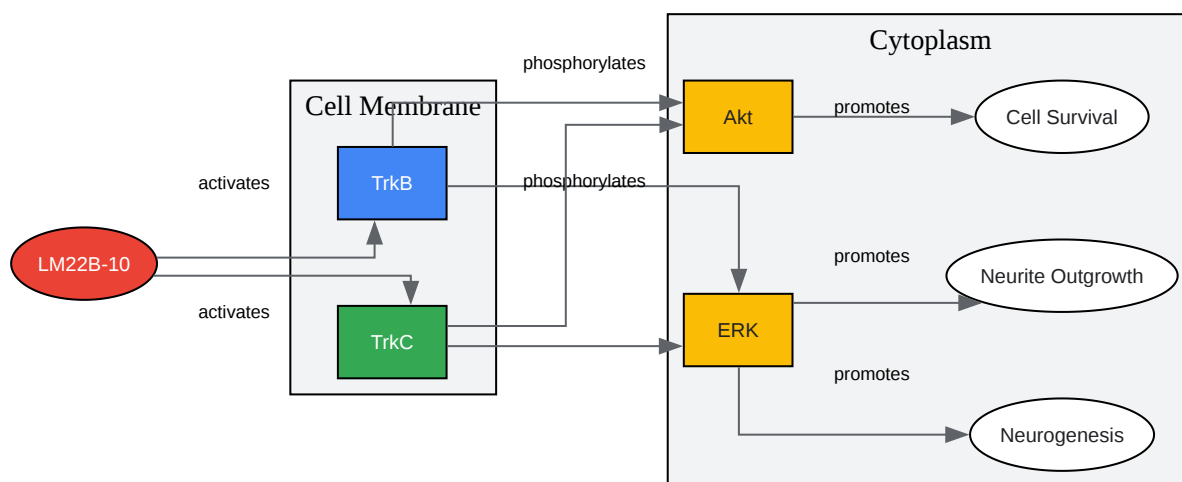

[Click to download full resolution via product page](#)

Figure 1: LM22B-10 Signaling Pathway.

Preclinical Efficacy in Traumatic Brain Injury Models

Studies utilizing a controlled cortical impact (CCI) injury model in rats have demonstrated the therapeutic potential of **LM22B-10**. Administration of the compound has been shown to reduce neuronal cell death in the injured cortex and increase the proliferation of neuroblasts in the hippocampus.[4][7]

Quantitative Data Summary

The following tables summarize the key quantitative findings from preclinical studies of **LM22B-10** in TBI.

Table 1: Effects of **LM22B-10** on Neurogenesis and Cell Survival

Outcome Measure	Animal Model	Treatment Group	Control Group	Result	Citation
DCX+ Cell Proliferation (Hippocampus)	Rat CCI Model	TBI + LM22B-10	TBI + Vehicle	~65.4% increase in DCX+ cells	[7]
DCX+/BrdU+ Cell Proliferation (Hippocampus)	Rat CCI Model	TBI + LM22B-10	TBI + Vehicle	~106% increase in DCX+/BrdU+ cells	[7]
Neuronal Cell Death (Injured Cortex)	Rat CCI Model	TBI + LM22B-10	TBI + Vehicle	Significant reduction in FJC-positive cells	[4][7]

DCX: Doublecortin (a marker for neuroblasts); BrdU: Bromodeoxyuridine (a marker for proliferating cells); FJC: Fluoro-Jade C (a marker for degenerating neurons).

Table 2: Effects of **LM22B-10** on Behavioral Outcomes following TBI

Behavioral Test	Animal Model	Treatment Group	Control Group	Outcome	Citation
Barnes Maze (Spatial Learning)	Rat CCI Model	TBI + LM22B-10	TBI + Vehicle	Partially reversed TBI-induced delay in task acquisition	[7][8]
Open Field Test (Anxiety-like Behavior)	Rat CCI Model	TBI + LM22B-10	TBI + Vehicle	Normalized the TBI-associated decrease in center entries	[7][8]
Elevated Plus Maze (Anxiety-like Behavior)	Rat CCI Model	TBI + LM22B-10	TBI + Vehicle	No significant recovery of performance	[7]

Interestingly, in uninjured (sham) animals, **LM22B-10** was observed to promote anxiety-like behavior and diminish spatial memory performance, suggesting that its therapeutic effects are context-dependent and compensatory in the injured brain.[3][7]

Experimental Protocols

Detailed methodologies are crucial for the replication and extension of these findings. The following sections outline the core experimental protocols used in **LM22B-10** TBI research.

Controlled Cortical Impact (CCI) Injury Model

The CCI model is a widely used and reproducible method for inducing TBI in rodents.

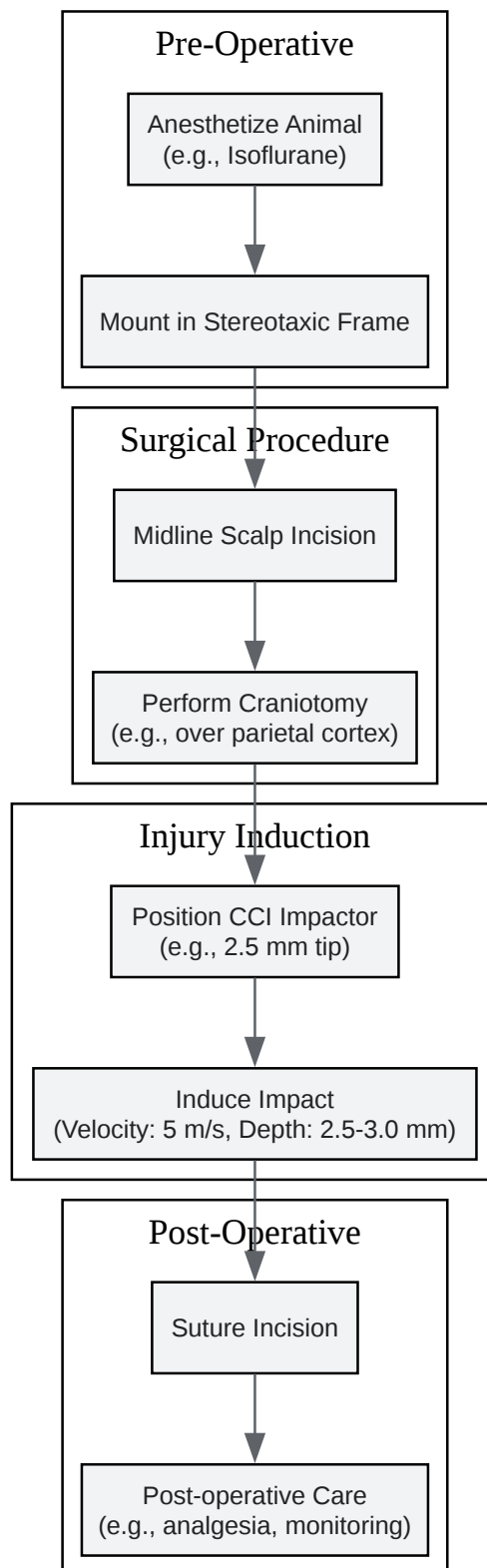

[Click to download full resolution via product page](#)

Figure 2: Controlled Cortical Impact (CCI) Experimental Workflow.

Key Parameters:

- **Animal Model:** Adult male Sprague-Dawley rats are commonly used.
- **Anesthesia:** Isoflurane is a typical anesthetic agent.
- **Impactor:** A pneumatic or electromagnetic impactor with a specific tip diameter (e.g., 2.5 mm) is used.^[9]
- **Injury Severity:** Parameters such as impact velocity (e.g., 5 m/s) and deformation depth (e.g., 2.5-3.0 mm) are controlled to create a moderate to severe injury.^[9]

LM22B-10 Administration

- **Formulation:** **LM22B-10** is often prepared for delivery in a vehicle such as Cremophor/Phosphate-buffered saline (PBS).^[7]
- **Dosage:** A common dosage used in rat models is 10 mg/kg.^{[7][10]}
- **Route of Administration:** Intraperitoneal (IP) injection is a frequently used route.^{[7][10]}
- **Treatment Regimen:** Treatment can be initiated shortly after TBI and continued for a specified duration (e.g., daily for 2 weeks).^[7]

Histological Analysis

- **Tissue Preparation:** Animals are euthanized at specific time points post-injury (e.g., 24 hours for cell death analysis, 7 days for neurogenesis). Brains are fixed, sectioned, and prepared for immunohistochemistry.
- **Cell Death Staining:** Fluoro-Jade C (FJC) staining is used to identify degenerating neurons in the perilesional cortex.^[4]
- **Neurogenesis Staining:** Immunohistochemistry for Doublecortin (DCX) and Bromodeoxyuridine (BrdU) is performed on hippocampal sections to quantify proliferating neuroblasts.^[4]

Behavioral Testing

- Barnes Maze: This test assesses spatial learning and memory. The animal is placed on an open circular platform with holes around the perimeter, one of which leads to an escape box. The latency and path length to find the escape box are measured over several trials.[8]
- Open Field Test: This test is used to evaluate general locomotor activity and anxiety-like behavior. The animal is placed in an open arena, and parameters such as total distance moved and time spent in the center versus the periphery are recorded.[8]
- Elevated Plus Maze: This maze, with two open and two enclosed arms, is another common test for anxiety-like behavior. The number of entries and time spent in the open arms are indicative of the animal's anxiety level.[7]

Discussion and Future Directions

The preclinical data strongly suggest that **LM22B-10** holds promise as a therapeutic agent for TBI. Its ability to co-activate TrkB and TrkC signaling pathways appears to effectively counter key aspects of TBI pathology, including neuronal death and impaired neurogenesis, leading to improved functional outcomes.[4][7]

However, several questions remain to be addressed in future research:

- Therapeutic Window: The optimal time for initiating **LM22B-10** treatment post-TBI needs to be determined.
- Dose-Response Relationship: A thorough investigation of the dose-dependent effects of **LM22B-10** on both therapeutic and potential adverse outcomes is warranted.
- Chronic Effects: Long-term studies are needed to assess the durability of the behavioral improvements and any potential chronic side effects.
- Combination Therapies: Exploring the synergistic effects of **LM22B-10** with other therapeutic strategies, such as anti-inflammatory agents or rehabilitation, could lead to enhanced recovery.

The bimodal response observed in injured versus uninjured animals underscores the complexity of neurotrophin signaling and highlights the importance of targeting such pathways in a disease-specific context.[7]

Conclusion

LM22B-10 represents a significant advancement in the development of small-molecule neurotrophin receptor agonists for CNS disorders. Its unique co-activation of TrkB and TrkC, coupled with its ability to cross the blood-brain barrier, makes it a highly attractive candidate for TBI therapeutics. The data summarized in this guide provide a solid foundation for further research and development, with the ultimate goal of translating this promising preclinical candidate into a clinically effective treatment for individuals suffering from traumatic brain injury.

Need Custom Synthesis?

BenchChem offers custom synthesis for rare earth carbides and specific isotopic labeling.

Email: info@benchchem.com or [Request Quote Online](#).

References

- [1. A small molecule TrkB/TrkC neurotrophin receptor co-activator with distinctive effects on neuronal survival and process outgrowth \[pubmed.ncbi.nlm.nih.gov\]](#)
- [2. \[PDF\] A Small-Molecule TrkB/TrkC Ligand Promotes Neurogenesis and Behavioral Recovery Following Traumatic Brain Injury | Semantic Scholar \[semanticscholar.org\]](#)
- [3. A Small-Molecule TrkB/TrkC Ligand Promotes Neurogenesis and Behavioral Recovery Following Traumatic Brain Injury. \[escholarship.org\]](#)
- [4. researchgate.net \[researchgate.net\]](#)
- [5. medchemexpress.com \[medchemexpress.com\]](#)
- [6. LM22B-10 | activator of TrkB/TrkC \(Tropomyosin-receptor kinase\) neurotrophin receptor | CAS 342777-54-2 | Buy LM22B10 from Supplier InvivoChem \[invivochem.com\]](#)
- [7. A Small-Molecule TrkB/TrkC Ligand Promotes Neurogenesis and Behavioral Recovery Following Traumatic Brain Injury - PMC \[pmc.ncbi.nlm.nih.gov\]](#)
- [8. researchgate.net \[researchgate.net\]](#)
- [9. TrkB-enhancer facilitates functional recovery after traumatic brain injury - PMC \[pmc.ncbi.nlm.nih.gov\]](#)
- [10. researchgate.net \[researchgate.net\]](#)

- To cite this document: BenchChem. [LM22B-10 for Traumatic Brain Injury Research: A Technical Guide]. BenchChem, [2026]. [Online PDF]. Available at: [<https://www.benchchem.com/product/b15608413/docs#lm22b-10-for-traumatic-brain-injury-research-a-technical-guide>]

Disclaimer & Data Validity:

The information provided in this document is for Research Use Only (RUO) and is strictly not intended for diagnostic or therapeutic procedures. While BenchChem strives to provide accurate protocols, we make no warranties, express or implied, regarding the fitness of this product for every specific experimental setup.

Technical Support: The protocols provided are for reference purposes. Unsure if this reagent suits your experiment?

Need Industrial/Bulk Grade? [Request Custom Synthesis Quote](#)

BenchChem

Our mission is to be the trusted global source of essential and advanced chemicals, empowering scientists and researchers to drive progress in science and industry.

Contact

Address: 3281 E Guasti Rd
Ontario, CA 91761, United States
Phone: (601) 213-4426
Email: info@benchchem.com

[Contact our Ph.D. Support Team for a compatibility check](#)