

# In-depth Technical Guide on ER-phagy Regulation

**Author:** BenchChem Technical Support Team. **Date:** April 2026

## Compound of Interest

Compound Name: SI-W052  
Cat. No.: B15608355

[Get Quote](#)

To our valued user:

Our comprehensive search for the compound "**SI-W052**" in the context of ER-phagy regulation did not yield any specific publicly available scientific literature or data. This suggests that "**SI-W052**" may be an internal compound designation not yet disclosed in the public domain, a very recent discovery, or a potential typographical error.

While we cannot provide a guide on the specific compound "**SI-W052**," we have compiled an in-depth technical guide on the core principles of ER-phagy regulation, a topic of significant interest in cell biology and drug development. This guide is tailored to researchers, scientists, and drug development professionals, and adheres to your specified requirements for data presentation, experimental protocols, and visualization of signaling pathways.

Below, we provide a detailed overview of ER-phagy, its key regulators, and the methodologies used to study this essential cellular process. We have also included information on known small molecule modulators of ER-phagy as illustrative examples of pharmacological intervention in this pathway.

# An In-depth Technical Guide to ER-phagy

## Regulation

### Introduction to ER-phagy

Endoplasmic reticulum (ER)-phagy is a selective autophagy process responsible for the degradation of portions of the endoplasmic reticulum. This process is crucial for maintaining ER homeostasis, clearing misfolded proteins, and adapting to cellular stress.[1][2][3] Dysregulation of ER-phagy has been implicated in a variety of human diseases, including neurodegenerative disorders and cancer.[1][3]

ER-phagy can be broadly categorized into two main pathways:

- Macro-ER-phagy: Sequestration of ER fragments by a double-membraned autophagosome, which then fuses with a lysosome for degradation.[1][2]
- Micro-ER-phagy: Direct engulfment of ER portions by the lysosomal or vacuolar membrane. [1][2]

This guide will focus primarily on the better-understood mechanisms of macro-ER-phagy.

### Key Regulators of ER-phagy

The specificity of ER-phagy is conferred by a set of ER-resident and cytosolic receptors that link the ER to the core autophagy machinery. These receptors typically contain a microtubule-associated protein 1 light chain 3 (LC3)-interacting region (LIR) that allows them to bind to ATG8-family proteins on the autophagosome.

Several key ER-phagy receptors have been identified in mammalian cells:

- FAM134B (Family with sequence similarity 134, member B): The first identified mammalian ER-phagy receptor, FAM134B, is located on ER sheets and contains a reticulon-homology domain (RHD) that promotes membrane curvature and scission.[4] Its expression can be upregulated by the small molecule Z36.[1][4]
- SEC62 (Sec62 homolog, preprotein translocation factor): This receptor is involved in "recovery ER-phagy," the process of reducing ER volume following the resolution of ER stress.

- RTN3L (Reticulon 3, long isoform): Primarily located in the tubular ER, RTN3L also possesses an RHD and is involved in ER fragmentation during ER-phagy.
- CCPG1 (Cell cycle progression 1): A single-pass transmembrane protein that can initiate ER-phagy.
- TEX264 (Testis expressed 264): Identified as a potent ER-phagy receptor under nutrient starvation conditions, it exhibits strong binding affinity for LC3 and GABARAP family proteins.[1]
- ATL3 (Atlastin GTPase 3): A dynamin-like GTPase that also functions as an ER-phagy receptor for the tubular ER, binding specifically to GABARAPs.[1][4]

## Signaling Pathways in ER-phagy Regulation

ER-phagy is tightly regulated by cellular stress and signaling pathways, most notably the Unfolded Protein Response (UPR).

The UPR is a set of signaling pathways activated by the accumulation of unfolded or misfolded proteins in the ER. The three main branches of the UPR (IRE1, PERK, and ATF6) can all influence ER-phagy. For instance, the UPR can transcriptionally upregulate ER-phagy receptors to enhance the clearance of damaged ER.

Diagram: The Unfolded Protein Response (UPR) and its connection to ER-phagy

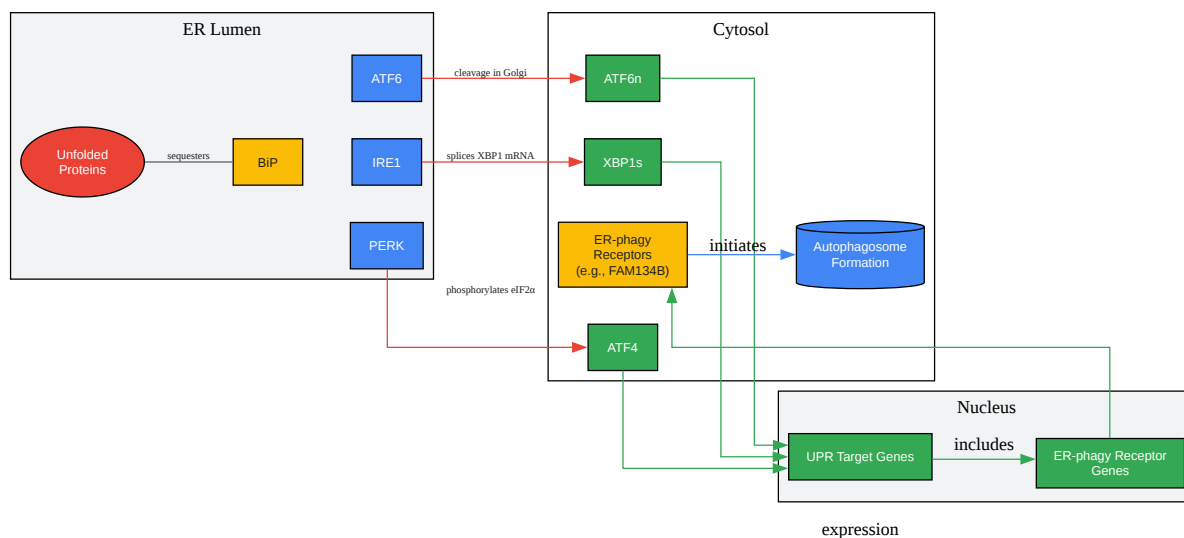

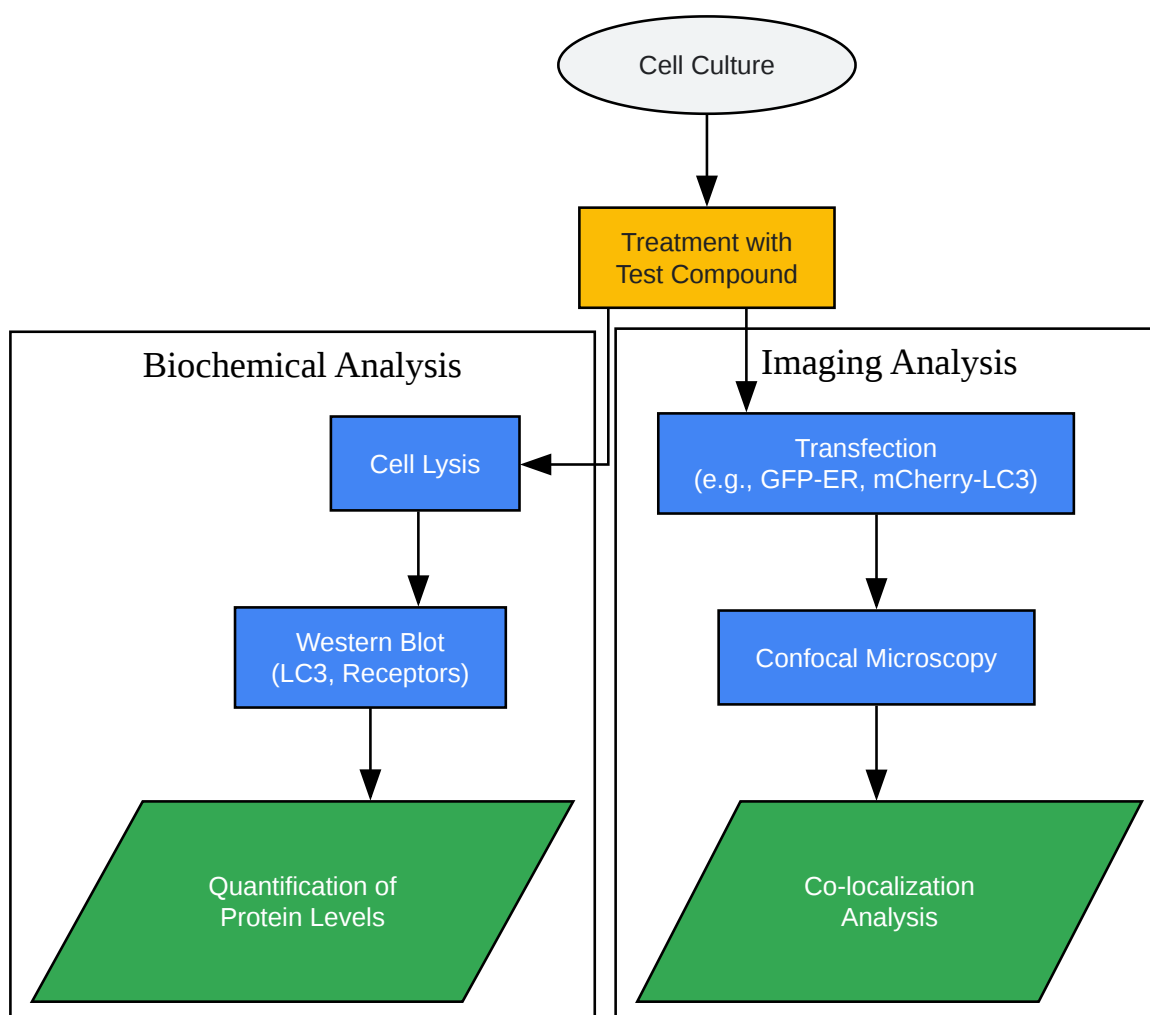

[Click to download full resolution via product page](#)

### Need Custom Synthesis?

BenchChem offers custom synthesis for rare earth carbides and specific isotopic labeling.

Email: [info@benchchem.com](mailto:info@benchchem.com) or [Request Quote Online](#).

## References

- 1. [Frontiers | ER-Phagy: A New Regulator of ER Homeostasis \[frontiersin.org\]](#)
- 2. [ER-phagy: mechanisms, regulation, and diseases connected to the lysosomal clearance of the endoplasmic reticulum - PMC \[pmc.ncbi.nlm.nih.gov\]](#)

- [3. journals.physiology.org \[journals.physiology.org\]](https://journals.physiology.org)
- [4. ER-Phagy: A New Regulator of ER Homeostasis - PMC \[pmc.ncbi.nlm.nih.gov\]](https://pubmed.ncbi.nlm.nih.gov/)
- To cite this document: BenchChem. [In-depth Technical Guide on ER-phagy Regulation]. BenchChem, [2026]. [Online PDF]. Available at: [\[https://www.benchchem.com/product/b15608355/docs#in-depth-technical-guide-on-er-phagy-regulation\]](https://www.benchchem.com/product/b15608355/docs#in-depth-technical-guide-on-er-phagy-regulation)

---

### Disclaimer & Data Validity:

The information provided in this document is for Research Use Only (RUO) and is strictly not intended for diagnostic or therapeutic procedures. While BenchChem strives to provide accurate protocols, we make no warranties, express or implied, regarding the fitness of this product for every specific experimental setup.

**Technical Support:** The protocols provided are for reference purposes. Unsure if this reagent suits your experiment?

**Need Industrial/Bulk Grade?** [Request Custom Synthesis Quote](#)

## BenchChem

Our mission is to be the trusted global source of essential and advanced chemicals, empowering scientists and researchers to drive progress in science and industry.

### Contact

Address: 3281 E Guasti Rd  
Ontario, CA 91761, United States  
Phone: (601) 213-4426  
Email: [info@benchchem.com](mailto:info@benchchem.com)

[Contact our Ph.D. Support Team for a compatibility check](#)