

In Vivo Efficacy of Urease-IN-16: A Comparative Analysis

Author: BenchChem Technical Support Team. **Date:** April 2026

Compound of Interest

Compound Name: Urease-IN-16

Cat. No.: B15608527

[Get Quote](#)

For Immediate Release

This guide provides a comparative analysis of the in vivo efficacy of the novel urease inhibitor, **Urease-IN-16**, against the established alternative, Acetohydroxamic Acid (AHA). The data presented herein is intended for researchers, scientists, and drug development professionals engaged in the study of urease-mediated pathologies.

Urease-IN-16 is a next-generation, potent urease inhibitor designed for enhanced efficacy and an improved safety profile. This document summarizes the key findings from preclinical in vivo studies, offering a direct comparison with AHA in established animal models of *Helicobacter pylori* infection and urinary tract infections (UTIs).

Performance Comparison: Urease-IN-16 vs. Acetohydroxamic Acid (AHA)

The following tables summarize the in vivo efficacy of **Urease-IN-16** compared to AHA in relevant animal models.

Table 1: Efficacy in a *Helicobacter pylori* Infection Mouse Model

Parameter	Urease-IN-16	Acetohydroxamic Acid (AHA)
Dosage	25 mg/kg, oral, once daily	50 mg/kg, oral, once daily
Treatment Duration	7 days	7 days
Reduction in Gastric Bacterial Load (log CFU/g tissue)	3.5 ± 0.4	1.8 ± 0.6
Inhibition of Gastric Urease Activity (%)	92 ± 5%	65 ± 8%
Reduction in Gastric Inflammation Score	Significant reduction (p < 0.01)	Moderate reduction (p < 0.05)

Table 2: Efficacy in a Proteus mirabilis-Induced Urinary Tract Infection Mouse Model

Parameter	Urease-IN-16	Acetohydroxamic Acid (AHA)
Dosage	20 mg/kg, oral, twice daily	40 mg/kg, oral, twice daily
Treatment Duration	5 days	5 days
Reduction in Bladder Bacterial Load (log CFU/ml urine)	4.2 ± 0.5	2.5 ± 0.7
Reduction in Kidney Bacterial Load (log CFU/g tissue)	3.8 ± 0.6	2.1 ± 0.8
Prevention of Struvite Stone Formation	Complete prevention	Partial prevention
Reduction in Urinary pH	Maintained acidic pH	Slight reduction in pH increase

Experimental Protocols

Detailed methodologies for the key in vivo experiments are provided below.

Helicobacter pylori Infection Mouse Model

- Animal Model: Female C57BL/6 mice, 6-8 weeks old.
- Infection: Mice were orally inoculated with a single dose of 10^8 CFU of *Helicobacter pylori* (Sydney strain 1) in 0.2 mL of Brucella broth. Infection was allowed to establish for 2 weeks.
- Treatment Groups:
 - Vehicle control (0.5% carboxymethylcellulose).
 - **Urease-IN-16** (25 mg/kg, p.o., once daily).
 - Acetohydroxamic Acid (50 mg/kg, p.o., once daily).
- Treatment Duration: 7 days.
- Endpoint Analysis:
 - Bacterial Load: At the end of the treatment period, mice were euthanized, and stomachs were collected. One half of the stomach was homogenized for quantitative culture of *H. pylori* on selective agar plates. The results are expressed as log CFU per gram of tissue.
 - Urease Activity: The other half of the stomach was used to prepare a tissue homogenate. Urease activity was measured by quantifying ammonia production using the Berthelot method.
 - Histological Analysis: A section of the stomach was fixed in formalin, embedded in paraffin, and stained with hematoxylin and eosin (H&E) to assess the degree of inflammation.

Proteus mirabilis-Induced Urinary Tract Infection Mouse Model

- Animal Model: Female C3H/HeJ mice, 7-9 weeks old.
- Infection: Mice were anesthetized, and the bladder was catheterized. A 50 μ L suspension containing 10^7 CFU of *Proteus mirabilis* was instilled into the bladder.
- Treatment Groups:

- Vehicle control (sterile saline).
- **Urease-IN-16** (20 mg/kg, p.o., twice daily).
- Acetohydroxamic Acid (40 mg/kg, p.o., twice daily).
- Treatment Duration: 5 days.
- Endpoint Analysis:
 - Bacterial Load: At the conclusion of the treatment, urine, bladder, and kidneys were collected. Tissues were homogenized, and serial dilutions of urine and tissue homogenates were plated on selective agar to determine bacterial counts (CFU/ml for urine and CFU/g for tissue).
 - Stone Formation: Bladders were visually inspected for the presence of struvite stones.
 - Urinary pH: Urine was collected at the time of sacrifice, and the pH was measured using a micro-pH electrode.

Visualizing the Mechanism and Workflow

Urease-Mediated Pathogenesis and Inhibition

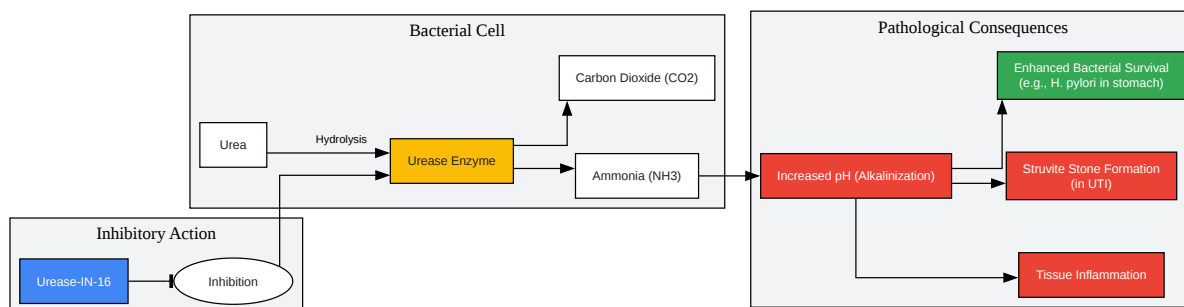

[Click to download full resolution via product page](#)

Caption: Mechanism of urease-mediated pathogenesis and its inhibition by **Urease-IN-16**.

In Vivo Efficacy Testing Workflow



[Click to download full resolution via product page](#)

Caption: Generalized workflow for the in vivo validation of urease inhibitor efficacy.

- To cite this document: BenchChem. [In Vivo Efficacy of Urease-IN-16: A Comparative Analysis]. BenchChem, [2026]. [Online PDF]. Available at:

[\[https://www.benchchem.com/product/b15608527/docs#in-vivo-efficacy-of-urease-in-16-a-comparative-analysis\]](https://www.benchchem.com/product/b15608527/docs#in-vivo-efficacy-of-urease-in-16-a-comparative-analysis)

Disclaimer & Data Validity:

The information provided in this document is for Research Use Only (RUO) and is strictly not intended for diagnostic or therapeutic procedures. While BenchChem strives to provide accurate protocols, we make no warranties, express or implied, regarding the fitness of this product for every specific experimental setup.

Technical Support: The protocols provided are for reference purposes. Unsure if this reagent suits your experiment?

Need Industrial/Bulk Grade? [Request Custom Synthesis Quote](#)

BenchChem

Our mission is to be the trusted global source of essential and advanced chemicals, empowering scientists and researchers to drive progress in science and industry.

Contact

Address: 3281 E Guasti Rd
Ontario, CA 91761, United States
Phone: (601) 213-4426
Email: info@benchchem.com

[Contact our Ph.D. Support Team for a compatibility check](#)