

# Benchmarking AMG410: A Comparative Guide to its Potency and Selectivity

**Author:** BenchChem Technical Support Team. **Date:** April 2026

## Compound of Interest

Compound Name: AMG410  
Cat. No.: B15608026

Get Quote

For Researchers, Scientists, and Drug Development Professionals

This guide provides a comprehensive comparison of the preclinical performance of **AMG410**, a novel pan-KRAS inhibitor, with other notable KRAS inhibitors. The data presented herein is collated from publicly available preclinical studies and is intended to provide an objective overview for research and drug development professionals.

## Executive Summary

**AMG410** is a non-covalent, orally bioavailable pan-KRAS inhibitor that demonstrates potent and selective activity against multiple KRAS mutations. Unlike first-generation KRAS inhibitors that exclusively target the KRAS G12C mutation, **AMG410** shows efficacy against a broader range of clinically relevant KRAS variants, including G12D, G12V, and G13D.[1] Furthermore, **AMG410** exhibits a unique dual-state inhibition mechanism, targeting both the active GTP-bound and inactive GDP-bound states of KRAS. A key differentiating feature of **AMG410** is its high selectivity for KRAS over other RAS isoforms, namely HRAS and NRAS, which may translate to a wider therapeutic window. This guide benchmarks **AMG410** against the KRAS G12C-specific inhibitors sotorasib and adagrasib, and the pan-RAS inhibitor daraxonrasib.

## Data Presentation

### Table 1: Biochemical Potency of AMG410 and Comparator Inhibitors

Compound	Target(s)	IC50 (nM) vs. KRAS G12D	IC50 (nM) vs. KRAS G12V	IC50 (nM) vs. KRAS G13D	IC50 (nM) vs. KRAS G12C
AMG410	pan-KRAS (G12D, G12V, G13D, etc.)	1-4	1-4	1-4	Not explicitly reported
Sotorasib	KRAS G12C	>7500 (insensitive)	Not reported	Not reported	~0.006 $\mu$ M (NCI-H358)
Adagrasib	KRAS G12C	Not reported	Not reported	Not reported	~5 nM (cellular IC50)
Daraxonrasib	pan-RAS (KRAS, HRAS, NRAS)	Not explicitly reported	Not explicitly reported	Not explicitly reported	Not explicitly reported

Note: Data is compiled from multiple sources and may not be from direct head-to-head studies. Cellular IC50 values can vary depending on the cell line and assay conditions.

### Table 2: Selectivity Profile of AMG410

Compound	Selectivity
AMG410	>100-fold selective for KRAS over HRAS and NRAS.[2]

### Table 3: Binding Affinity of AMG410

Compound	Binding to KRAS (GDP-state) - KD (nM)	Binding to KRAS (GTP-state) - KD (nM)
AMG410	1	22

## Mandatory Visualization

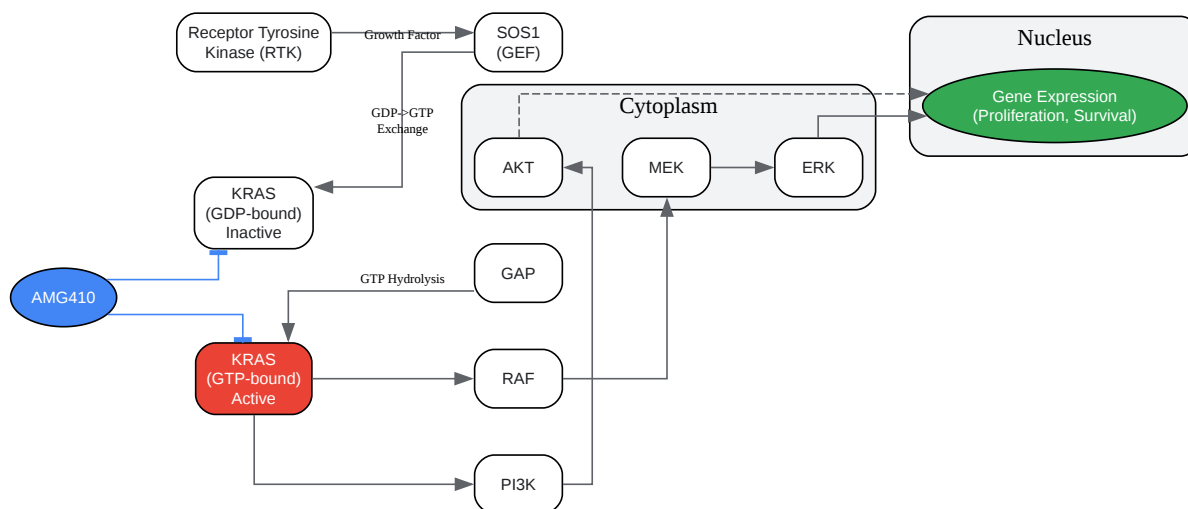

[Click to download full resolution via product page](#)

Caption: KRAS Signaling Pathway and Mechanism of **AMG410** Action.

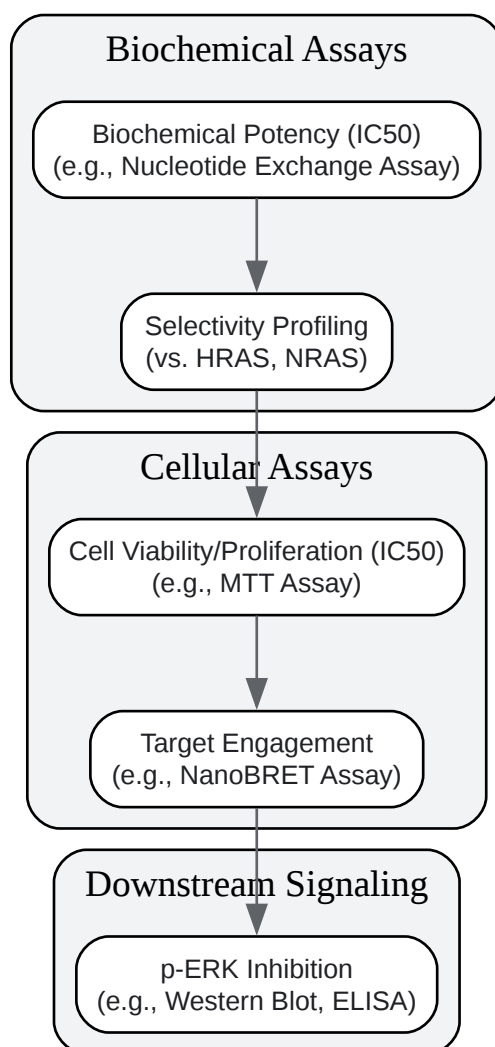

[Click to download full resolution via product page](#)

Caption: Experimental Workflow for KRAS Inhibitor Evaluation.

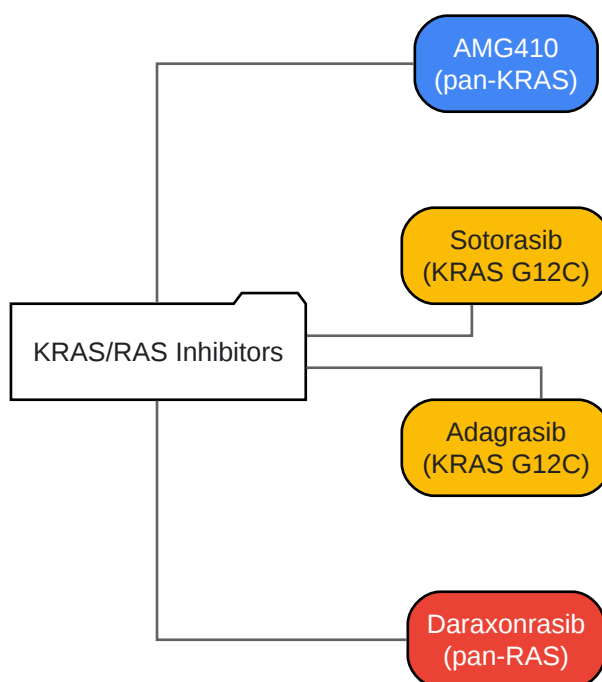

[Click to download full resolution via product page](#)

Caption: Logical Comparison of KRAS/RAS Inhibitor Selectivity.

## Experimental Protocols

### Biochemical Assays for Potency (IC<sub>50</sub>) Determination

Principle: Biochemical assays, such as nucleotide exchange assays, are utilized to determine the half-maximal inhibitory concentration (IC<sub>50</sub>) of a compound against purified KRAS protein mutants. These assays measure the inhibitor's ability to block the exchange of GDP for GTP, a critical step in KRAS activation.

Protocol Outline (based on a typical TR-FRET assay):

- Reagent Preparation:
  - Recombinant human KRAS mutant proteins (e.g., G12D, G12V, G13D) are biotinylated.
  - A fluorescently labeled GDP analog (e.g., BODIPY-FL-GDP) and a terbium-labeled streptavidin (Tb-SA) are used.

- The guanine nucleotide exchange factor SOS1 is used to catalyze the nucleotide exchange.
- Unlabeled GTP is used to compete with the fluorescent GDP.
- Test compounds (e.g., **AMG410**) are serially diluted.
- Assay Procedure:
  - Biotinylated KRAS protein is pre-incubated with Tb-SA and BODIPY-FL-GDP.
  - The test compound dilutions are added to the KRAS-probe complex and incubated.
  - The nucleotide exchange reaction is initiated by adding a mixture of SOS1 and unlabeled GTP.
  - The reaction is incubated to allow for nucleotide exchange.
- Data Acquisition:
  - Time-Resolved Fluorescence Resonance Energy Transfer (TR-FRET) signals are measured using a plate reader. The signal decreases as the fluorescent GDP is displaced by unlabeled GTP.
  - The percentage of inhibition is calculated for each compound concentration.
- Data Analysis:
  - IC50 values are determined by fitting the dose-response data to a four-parameter logistic equation using graphing software.[\[3\]](#)

## Cellular Assays for Potency (IC50) Determination

Principle: Cell-based proliferation assays, such as the MTT assay, are used to assess the ability of an inhibitor to reduce the viability of cancer cell lines harboring specific KRAS mutations.

Protocol Outline (MTT Assay):

- Cell Culture and Seeding:
  - Cancer cell lines with known KRAS mutations (e.g., NCI-H358 for KRAS G12C, MIA PaCa-2 for KRAS G12D) are cultured in appropriate media.
  - Cells are seeded into 96-well plates at a predetermined density and allowed to adhere overnight.
- Compound Treatment:
  - The test inhibitor is serially diluted in culture medium.
  - The medium in the cell plates is replaced with medium containing the various concentrations of the inhibitor. Control wells receive vehicle (e.g., DMSO) only.
- Incubation:
  - Plates are incubated for a specified period (e.g., 72 hours) to allow the inhibitor to exert its effect.
- MTT Addition and Incubation:
  - A solution of 3-(4,5-dimethylthiazol-2-yl)-2,5-diphenyltetrazolium bromide (MTT) is added to each well.
  - Plates are incubated for a few hours, during which viable cells metabolize the MTT into formazan crystals.
- Formazan Solubilization:
  - The medium is removed, and a solubilizing agent (e.g., DMSO) is added to each well to dissolve the formazan crystals.
- Data Acquisition and Analysis:
  - The absorbance of each well is measured at a specific wavelength (e.g., 570 nm) using a microplate reader.

- The percentage of cell viability is calculated relative to the vehicle-treated control cells.
- IC50 values are determined by plotting the percentage of viability against the logarithm of the inhibitor concentration and fitting the data to a dose-response curve.[4][5][6]

## Target Engagement Assays

Principle: NanoBRET™ (Bioluminescence Resonance Energy Transfer) Target Engagement Assays are used to measure the binding of a compound to its target protein within intact, live cells. This provides a quantitative measure of target occupancy.

Protocol Outline (NanoBRET™):

- Cell Preparation:
  - Cells are transiently transfected with a vector expressing the target KRAS protein fused to NanoLuc® luciferase.
- Assay Setup:
  - Transfected cells are harvested and resuspended in assay medium.
  - A cell-permeable fluorescent tracer that binds to the KRAS target is added to the cell suspension.
  - The test compound is serially diluted.
- Competitive Binding:
  - The cell suspension containing the tracer is dispensed into a multi-well plate.
  - The serially diluted test compound is added to the wells.
- Signal Detection:
  - A substrate for NanoLuc® luciferase and a cell-impermeable inhibitor of extracellular NanoLuc® are added.

- The BRET signal (energy transfer from NanoLuc® to the fluorescent tracer) and the NanoLuc® luminescence are measured simultaneously using a specialized plate reader.
- Data Analysis:
  - The BRET ratio is calculated. A decrease in the BRET ratio with increasing concentrations of the test compound indicates displacement of the tracer and binding of the compound to the target.
  - The apparent cellular affinity (e.g., IC50) is determined from the dose-response curve.[\[7\]](#)  
[\[8\]](#)[\[9\]](#)[\[10\]](#)

## Downstream Signaling Assays (p-ERK Inhibition)

Principle: Western blotting is a common method to assess the inhibition of downstream signaling pathways. The phosphorylation of ERK (p-ERK) is a key marker of KRAS pathway activation. A reduction in p-ERK levels indicates effective inhibition of the KRAS signaling cascade.

Protocol Outline (Western Blot):

- Cell Treatment and Lysis:
  - KRAS-mutant cancer cells are treated with various concentrations of the inhibitor for a specific duration.
  - After treatment, cells are washed and then lysed in a buffer containing protease and phosphatase inhibitors to preserve protein phosphorylation.
- Protein Quantification:
  - The total protein concentration in each cell lysate is determined using a protein assay (e.g., BCA assay).
- SDS-PAGE and Protein Transfer:
  - Equal amounts of protein from each sample are separated by size using sodium dodecyl sulfate-polyacrylamide gel electrophoresis (SDS-PAGE).

- The separated proteins are then transferred from the gel to a membrane (e.g., PVDF or nitrocellulose).
- Immunoblotting:
  - The membrane is blocked to prevent non-specific antibody binding.
  - The membrane is incubated with a primary antibody specific for phosphorylated ERK (p-ERK).
  - After washing, the membrane is incubated with a secondary antibody conjugated to an enzyme (e.g., HRP).
  - The membrane is then stripped and re-probed with an antibody for total ERK to serve as a loading control.
- Detection and Analysis:
  - A chemiluminescent substrate is added to the membrane, and the signal is detected using an imaging system.
  - The band intensities for p-ERK and total ERK are quantified. The p-ERK signal is normalized to the total ERK signal to determine the extent of inhibition.<sup>[11][12][13]</sup>

### *Need Custom Synthesis?*

*BenchChem offers custom synthesis for rare earth carbides and specific isotopic labeling.*

*Email: [info@benchchem.com](mailto:info@benchchem.com) or [Request Quote Online](#).*

## References

- [1. trial.medpath.com](https://www.trial.medpath.com) [[trial.medpath.com](https://www.trial.medpath.com)]
- [2. aacrjournals.org](https://aacrjournals.org) [[aacrjournals.org](https://aacrjournals.org)]
- [3. biorxiv.org](https://www.biorxiv.org) [[biorxiv.org](https://www.biorxiv.org)]
- [4. benchchem.com](https://www.benchchem.com) [[benchchem.com](https://www.benchchem.com)]
- [5. aacrjournals.org](https://aacrjournals.org) [[aacrjournals.org](https://aacrjournals.org)]

- [6. researchgate.net \[researchgate.net\]](#)
- [7. NanoBRET™ Target Engagement Intracellular BET BRD Assay Protocol \[promega.kr\]](#)
- [8. NanoBRET® Target Engagement BET BRD Assays \[promega.com\]](#)
- [9. eubopen.org \[eubopen.org\]](#)
- [10. NanoBRET® Target Engagement | Live-Cell Compound Binding Assay \[worldwide.promega.com\]](#)
- [11. Measuring agonist-induced ERK MAP kinase phosphorylation for G-protein-coupled receptors - PMC \[pmc.ncbi.nlm.nih.gov\]](#)
- [12. 3.4. Western Blotting and Detection \[bio-protocol.org\]](#)
- [13. benchchem.com \[benchchem.com\]](#)
- To cite this document: BenchChem. [Benchmarking AMG410: A Comparative Guide to its Potency and Selectivity]. BenchChem, [2026]. [Online PDF]. Available at: [\[https://www.benchchem.com/product/b15608026/docs#benchmarking-amg410-a-comparative-guide-to-its-potency-and-selectivity\]](https://www.benchchem.com/product/b15608026/docs#benchmarking-amg410-a-comparative-guide-to-its-potency-and-selectivity)

---

#### Disclaimer & Data Validity:

The information provided in this document is for Research Use Only (RUO) and is strictly not intended for diagnostic or therapeutic procedures. While BenchChem strives to provide accurate protocols, we make no warranties, express or implied, regarding the fitness of this product for every specific experimental setup.

**Technical Support:** The protocols provided are for reference purposes. Unsure if this reagent suits your experiment?

**Need Industrial/Bulk Grade?** [Request Custom Synthesis Quote](#)

## BenchChem

Our mission is to be the trusted global source of essential and advanced chemicals, empowering scientists and researchers to drive progress in science and industry.

#### Contact

Address: 3281 E Guasti Rd  
Ontario, CA 91761, United States  
Phone: (601) 213-4426  
Email: [info@benchchem.com](mailto:info@benchchem.com)

Contact our Ph.D. Support Team for a compatibility check