

Application Notes and Protocols for TX-1123 in Animal Models

Author: BenchChem Technical Support Team. **Date:** April 2026

Compound of Interest

Compound Name: TX-1123
Cat. No.: B15608278

[Get Quote](#)

A notable gap exists in the currently available scientific literature regarding the in vivo application of **TX-1123** in animal models. While in vitro studies have characterized **TX-1123** as a dual inhibitor of Protein Tyrosine Kinases (PTKs) and Cyclooxygenase-2 (COX-2), detailed protocols and quantitative data from preclinical animal studies are not publicly available. This document aims to provide a foundational guide for researchers and drug development professionals by summarizing the known in vitro data and outlining general principles and methodologies that could be adapted for the future in vivo evaluation of **TX-1123**.

Introduction to TX-1123

TX-1123 is a synthetic compound identified as a potent inhibitor of several protein tyrosine kinases, including Src, as well as the COX-2 enzyme. Its dual mechanism of action suggests potential therapeutic applications in oncology and inflammatory diseases.

Mechanism of Action and Signaling Pathways

TX-1123 exerts its biological effects by targeting key signaling molecules involved in cell proliferation, survival, and inflammation.

- Protein Tyrosine Kinase (PTK) Inhibition: **TX-1123** has been shown to inhibit the activity of Src family kinases. Src is a non-receptor tyrosine kinase that plays a crucial role in regulating cell adhesion, growth, and differentiation. Its aberrant activation is frequently observed in various cancers, contributing to tumor progression and metastasis.
- Cyclooxygenase-2 (COX-2) Inhibition: **TX-1123** selectively inhibits COX-2, an enzyme responsible for the production of prostaglandins that mediate inflammation and pain. Overexpression of COX-2 has also been implicated in the pathogenesis of several types of cancer.

Below is a diagram illustrating the signaling pathways targeted by **TX-1123**.

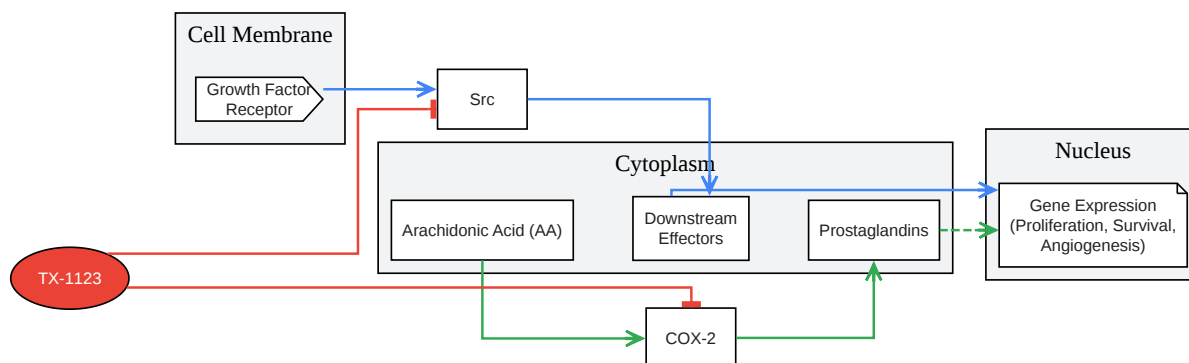

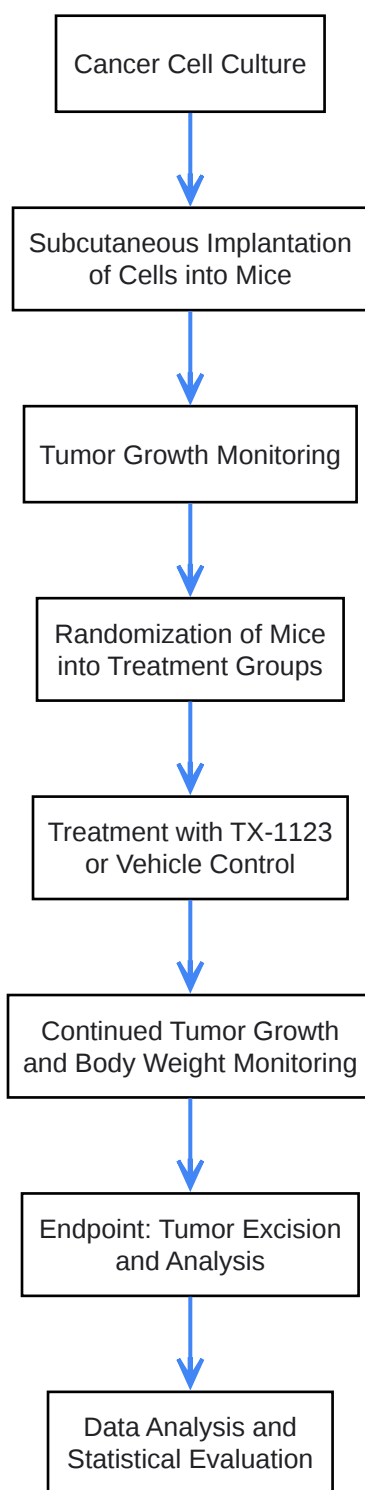

[Click to download full resolution via product page](#)

- To cite this document: BenchChem. [Application Notes and Protocols for TX-1123 in Animal Models]. BenchChem, [2026]. [Online PDF]. Available at: [\[https://www.benchchem.com/product/b15608278/docs#application-notes-and-protocols-for-tx-1123-in-animal-models\]](https://www.benchchem.com/product/b15608278/docs#application-notes-and-protocols-for-tx-1123-in-animal-models)

Disclaimer & Data Validity:

The information provided in this document is for Research Use Only (RUO) and is strictly not intended for diagnostic or therapeutic procedures. While BenchChem strives to provide accurate protocols, we make no warranties, express or implied, regarding the fitness of this product for every specific experimental setup.

Technical Support: The protocols provided are for reference purposes. Unsure if this reagent suits your experiment?

Need Industrial/Bulk Grade? [Request Custom Synthesis Quote](#)

BenchChem

Our mission is to be the trusted global source of essential and advanced chemicals, empowering scientists and researchers to drive progress in science and industry.

Contact

Address: 3281 E Guasti Rd
Ontario, CA 91761, United States
Phone: (601) 213-4426
Email: info@benchchem.com

[Contact our Ph.D. Support Team for a compatibility check](#)