

Application Notes and Protocols: GSK3008348 for In Vivo Studies

Author: BenchChem Technical Support Team. **Date:** April 2026

Compound of Interest

Compound Name: GSK 3008348

Cat. No.: B15608470

[Get Quote](#)

For Researchers, Scientists, and Drug Development Professionals

Introduction

GSK3008348 is a potent and selective small molecule antagonist of the $\alpha\beta6$ integrin.[1] Integrins are transmembrane receptors that mediate cell-matrix and cell-cell interactions, and the $\alpha\beta6$ integrin is of particular interest due to its role in activating transforming growth factor-beta (TGF- β), a key cytokine in fibrosis.[2][3][4] GSK3008348, by inhibiting $\alpha\beta6$, effectively blocks TGF- β activation and downstream pro-fibrotic signaling.[1][2] This document provides detailed application notes and protocols for the in vivo use of GSK3008348, with a focus on preclinical models of idiopathic pulmonary fibrosis (IPF).

Mechanism of Action

GSK3008348 is an RGD-mimetic, meaning it mimics the Arginine-Glycine-Aspartic acid motif found in the natural ligands of many integrins.[3] It binds with high affinity to the $\alpha\beta6$ integrin, preventing it from binding to the latency-associated peptide (LAP) of latent TGF- β . [3] This interaction is crucial for the activation of TGF- β . By blocking this step, GSK3008348 effectively reduces the levels of active TGF- β in the local microenvironment, thereby mitigating pro-fibrotic processes such as collagen deposition.[2][5] Furthermore, binding of GSK3008348 to $\alpha\beta6$ on

human lung epithelial cells induces rapid internalization and lysosomal degradation of the integrin, leading to a prolonged inhibition of TGF- β signaling.[2][6][7]

Signaling Pathway

The signaling pathway inhibited by GSK3008348 is central to the pathogenesis of fibrotic diseases. The diagram below illustrates the mechanism of action.

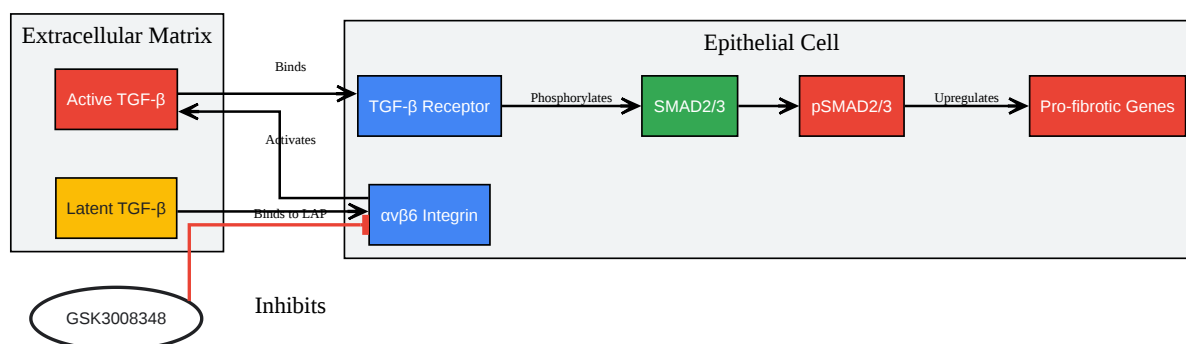

[Click to download full resolution via product page](#)

Caption: Mechanism of GSK3008348 in inhibiting TGF- β activation.

Recommended Dosage for In Vivo Studies

The following table summarizes the recommended dosages of GSK3008348 for in vivo studies based on preclinical mouse models of lung fibrosis.

Animal Model	Route of Administration	Dosage	Dosing Schedule	Key Readouts	Reference
Bleomycin-induced lung fibrosis (Mouse)	Intranasal	1 mg/kg	Not specified	α v β 6 engagement, pSMAD2 levels	[8]
Bleomycin-induced lung fibrosis (Mouse)	Subcutaneous (osmotic minipumps)	1.5 mg/kg/day	Continuous infusion	Lung exposure	[9]
Bleomycin-induced lung fibrosis (Mouse)	Subcutaneous (osmotic minipumps)	15 mg/kg/day	Continuous infusion	Lung exposure, ex vivo binding	[9]

Experimental Protocols

Bleomycin-Induced Lung Fibrosis Model in Mice

This model is widely used to study the pathogenesis of pulmonary fibrosis and to evaluate the efficacy of anti-fibrotic agents.

Materials:

- GSK3008348
- Bleomycin sulfate
- Sterile saline
- Anesthesia (e.g., isoflurane, ketamine/xylazine)
- C57BL/6 mice (male, 8-12 weeks old)
- Intratracheal or intranasal administration equipment

- Osmotic minipumps (for subcutaneous delivery)
- Surgical tools for minipump implantation

Experimental Workflow:

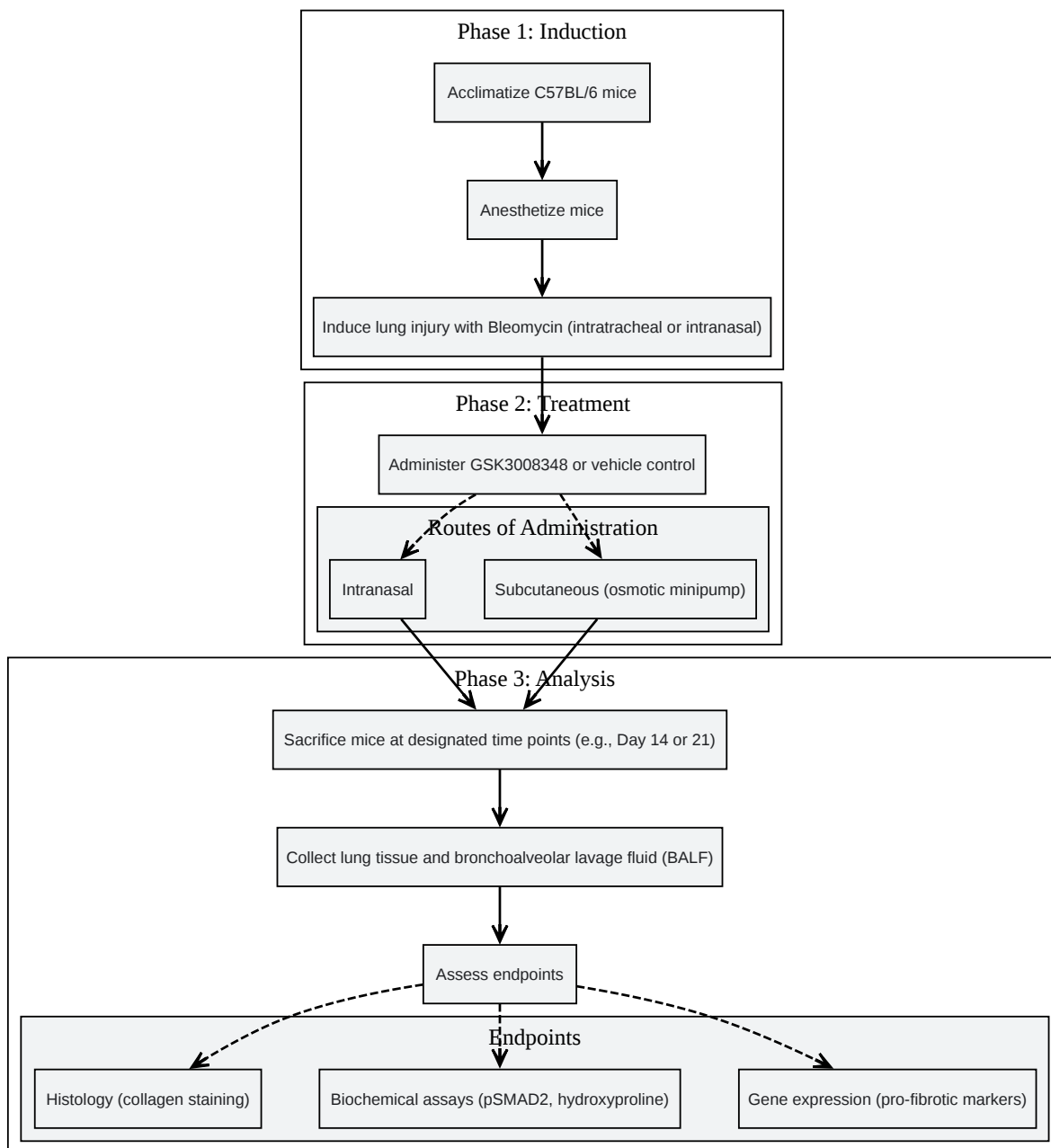

[Click to download full resolution via product page](#)

Caption: Workflow for a bleomycin-induced lung fibrosis study.

Detailed Protocol:

- Acclimatization: Acclimatize male C57BL/6 mice for at least one week before the experiment.
- Induction of Fibrosis:
 - Anesthetize mice using a suitable anesthetic.
 - Administer a single dose of bleomycin sulfate (typically 1.5-3.0 U/kg) dissolved in sterile saline via intratracheal or intranasal instillation. A control group should receive sterile saline only.
- GSK3008348 Administration:
 - Intranasal Administration: As described in one study, a dose of 1 mg/kg can be administered.[8] The frequency and timing of administration relative to bleomycin injury should be optimized for the specific study design.
 - Subcutaneous Administration via Osmotic Minipumps: For continuous delivery, osmotic minipumps can be implanted subcutaneously on the back of the mice. Pumps can be filled with GSK3008348 to deliver doses such as 1.5 or 15 mg/kg/day.[9] Implantation should be performed under sterile surgical conditions.
- Monitoring: Monitor the animals daily for signs of distress, weight loss, and changes in behavior.
- Endpoint Analysis:
 - At a predetermined time point (e.g., 14 or 21 days post-bleomycin), euthanize the mice.
 - Collect bronchoalveolar lavage fluid (BALF) for cell counts and cytokine analysis.
 - Harvest the lungs. One lung can be fixed in formalin for histological analysis (e.g., Masson's trichrome staining for collagen), and the other can be snap-frozen for biochemical and molecular analyses.
 - Key Endpoints:

- pSMAD2 levels: A key pharmacodynamic marker of TGF- β pathway activation.[8]
- Collagen deposition: Can be quantified from histological sections or by measuring hydroxyproline content in lung homogenates.[2]
- Gene expression: Analyze the expression of pro-fibrotic genes (e.g., Col1a1, Acta2) by qPCR.

Concluding Remarks

GSK3008348 is a valuable tool for investigating the role of the $\alpha v \beta 6$ integrin and TGF- β signaling in fibrosis and other relevant disease models. The provided protocols and dosage information serve as a starting point for in vivo studies. Researchers should optimize the experimental conditions based on their specific research questions and animal models. It is important to note that while GSK3008348 showed promise in preclinical studies and was well-tolerated in early clinical trials, its development for IPF was discontinued.[4][10][11] Nevertheless, it remains a critical pharmacological tool for research purposes.

Need Custom Synthesis?

BenchChem offers custom synthesis for rare earth carbides and specific isotopic labeling.

Email: info@benchchem.com or [Request Quote Online](#).

References

- [1. medchemexpress.com \[medchemexpress.com\]](https://www.medchemexpress.com)
- [2. researchgate.net \[researchgate.net\]](https://www.researchgate.net)
- [3. GSK3008348 | Ligand page | IUPHAR/BPS Guide to PHARMACOLOGY \[guidetopharmacology.org\]](https://www.guidetopharmacology.org)
- [4. Integrins and pulmonary fibrosis: Pathogenic roles and therapeutic opportunities - PMC \[pmc.ncbi.nlm.nih.gov\]](https://pubmed.ncbi.nlm.nih.gov/12345678/)
- [5. mdpi.com \[mdpi.com\]](https://www.mdpi.com)
- [6. Translational pharmacology of an inhaled small molecule \$\alpha v \beta 6\$ integrin inhibitor for idiopathic pulmonary fibrosis - PubMed \[pubmed.ncbi.nlm.nih.gov\]](https://pubmed.ncbi.nlm.nih.gov/12345678/)

- [7. Translational pharmacology of an inhaled small molecule \$\alpha\beta6\$ integrin inhibitor for idiopathic pulmonary fibrosis - UCL Discovery \[discovery.ucl.ac.uk\]](#)
- [8. pa2online.org \[pa2online.org\]](#)
- [9. GSK-3008348 | integrin alpha\(v\)beta6 antagonist | IPF| CAS 1629249-33-7 | Buy GSK3008348 from Supplier InvivoChem \[invivochem.com\]](#)
- [10. researchgate.net \[researchgate.net\]](#)
- [11. academic.oup.com \[academic.oup.com\]](#)
- To cite this document: BenchChem. [Application Notes and Protocols: GSK3008348 for In Vivo Studies]. BenchChem, [2026]. [Online PDF]. Available at: [\[https://www.benchchem.com/product/b15608470/docs#application-notes-and-protocols-gsk3008348-for-in-vivo-studies\]](https://www.benchchem.com/product/b15608470/docs#application-notes-and-protocols-gsk3008348-for-in-vivo-studies)

Disclaimer & Data Validity:

The information provided in this document is for Research Use Only (RUO) and is strictly not intended for diagnostic or therapeutic procedures. While BenchChem strives to provide accurate protocols, we make no warranties, express or implied, regarding the fitness of this product for every specific experimental setup.

Technical Support: The protocols provided are for reference purposes. Unsure if this reagent suits your experiment?

Need Industrial/Bulk Grade? [Request Custom Synthesis Quote](#)

BenchChem

Our mission is to be the trusted global source of essential and advanced chemicals, empowering scientists and researchers to drive progress in science and industry.

Contact

Address: 3281 E Guasti Rd
Ontario, CA 91761, United States
Phone: (601) 213-4426
Email: info@benchchem.com

Contact our Ph.D. Support Team for a compatibility check