

Validating MG149 Inhibition of Tip60: A Comparative Guide for Researchers

Author: BenchChem Technical Support Team. **Date:** May 2026

Compound of Interest

Compound Name: MG149
Cat. No.: B15607072

[Get Quote](#)

For researchers, scientists, and drug development professionals, this guide provides an objective comparison of **MG149**'s performance as a Tip60 inhibitor against other notable alternatives, supported by experimental data. This document summarizes key quantitative data, details experimental methodologies, and visualizes relevant biological pathways and workflows to aid in the critical evaluation of Tip60 targeted therapeutic strategies.

Introduction to Tip60 and its Inhibition

Tip60, also known as KAT5, is a crucial histone acetyltransferase (HAT) involved in a myriad of cellular processes, including transcriptional regulation, DNA damage repair, and apoptosis.[1] Its dysregulation is implicated in various diseases, particularly cancer, making it a compelling target for therapeutic intervention.[2] A growing number of small molecule inhibitors have been developed to target Tip60, with **MG149** being a prominent example. This guide focuses on the validation of **MG149**'s inhibitory action on Tip60 and provides a comparative analysis with other widely studied Tip60 inhibitors, NU9056 and TH1834.

Comparative Analysis of Tip60 Inhibitors

MG149, NU9056, and TH1834 are all small molecules designed to inhibit the acetyltransferase activity of Tip60. However, they exhibit distinct profiles in terms of potency, selectivity, and

cellular effects. A critical finding in recent studies is the dual-action of these compounds: they can act as activators of Tip60 at lower concentrations and as inhibitors at higher concentrations.^[3]^[4]

Quantitative Data Summary

The following table summarizes the key quantitative data for **MG149** and its alternatives. It is important to note that IC50 values can vary between different studies and assay conditions.

Inhibitor	Target(s)	IC50 (in vitro)	Cellular Potency (GI50)	Key Cellular Effects
MG149	Tip60, MOF (KAT8)	Tip60: 74 μ M[2]; MOF: 47 μ M[2]	Not widely reported	Inhibits p53 and NF- κ B pathways; Dual effect: activates at low-mid concentrations (1-100 μ M), inhibits at high concentrations (1-2 mM) in HAT assays[3]
NU9056	Tip60 (selective over p300, PCAF, GCN5)	~2 μ M[5][6]	8-27 μ M (prostate cancer cell lines)[5]	Induces apoptosis via caspase activation[5]; Inhibits ATM phosphorylation[5]; Dual effect: activates at low-mid concentrations, inhibits at high concentrations[3]

TH1834	Tip60 (specific)	Not explicitly defined in a single IC50 value	Induces apoptosis in breast cancer cells[7]	Increases DNA damage in breast cancer cells[7]; Does not affect MOF activity[7]; Dual effect: activates at low-mid concentrations, inhibits at high concentrations[3]
--------	------------------	---	---	---

Experimental Protocols

Detailed methodologies are crucial for the replication and validation of experimental findings. Below are protocols for key experiments used to characterize Tip60 inhibitors.

In Vitro Histone Acetyltransferase (HAT) Assay

This assay directly measures the enzymatic activity of Tip60 and its inhibition by compounds like **MG149**.

Principle: Recombinant Tip60 is incubated with a histone substrate (e.g., histone H3 or H4 peptide) and acetyl-CoA. The transfer of the acetyl group to the histone is quantified, often using a colorimetric or radioactive method.

Protocol:

- **Reaction Setup:** In a 96-well plate, combine recombinant Tip60 enzyme, the histone peptide substrate, and the HAT assay buffer.
- **Inhibitor Addition:** Add varying concentrations of the Tip60 inhibitor (e.g., **MG149**, NU9056, or TH1834) or DMSO (vehicle control) to the wells.
- **Initiate Reaction:** Start the reaction by adding Acetyl-CoA.
- **Incubation:** Incubate the plate at 30°C for a defined period (e.g., 30-60 minutes).

- Detection:
 - Colorimetric Method: Add a developing reagent that reacts with the co-product of the reaction (Coenzyme A) to produce a colorimetric signal, which is then measured using a plate reader.[8]
 - Radioactive Method: Use [3H]-labeled Acetyl-CoA. After the reaction, the radiolabeled histone substrate is captured on a filter membrane, and the radioactivity is measured using a scintillation counter.[9]
- Data Analysis: Calculate the percentage of Tip60 activity relative to the vehicle control for each inhibitor concentration to determine the IC50 value.

Cellular Tip60 Inhibition Assay (Western Blotting)

This assay assesses the effect of Tip60 inhibitors on the acetylation of its downstream targets within a cellular context.

Principle: Cells are treated with the Tip60 inhibitor, and the levels of acetylated downstream proteins (e.g., acetylated-p53, γ H2AX) are measured by Western blotting.

Protocol:

- Cell Culture and Treatment: Plate cells (e.g., cancer cell lines) and allow them to adhere. Treat the cells with different concentrations of the Tip60 inhibitor or DMSO for a specified duration.
- Cell Lysis: Wash the cells with ice-cold PBS and lyse them using a suitable lysis buffer (e.g., RIPA buffer) containing protease and deacetylase inhibitors.[10]
- Protein Quantification: Determine the protein concentration of the cell lysates using a protein assay (e.g., BCA assay).
- SDS-PAGE and Transfer: Separate equal amounts of protein from each sample by SDS-polyacrylamide gel electrophoresis (SDS-PAGE) and transfer the proteins to a nitrocellulose or PVDF membrane.[11]
- Immunoblotting:

- Block the membrane with a blocking solution (e.g., 5% non-fat milk in TBST) to prevent non-specific antibody binding.
- Incubate the membrane with a primary antibody specific for the acetylated target protein (e.g., anti-acetyl-p53 (Lys120)) overnight at 4°C.
- Wash the membrane and incubate with a horseradish peroxidase (HRP)-conjugated secondary antibody.
- Detection: Detect the protein bands using an enhanced chemiluminescence (ECL) substrate and an imaging system.
- Analysis: Quantify the band intensities and normalize them to a loading control (e.g., β -actin or GAPDH) to determine the relative levels of the acetylated protein.

Visualizing Molecular Interactions and Workflows

Diagrams created using Graphviz (DOT language) help to visualize complex signaling pathways and experimental procedures.

Tip60-Mediated DNA Damage Response Pathway

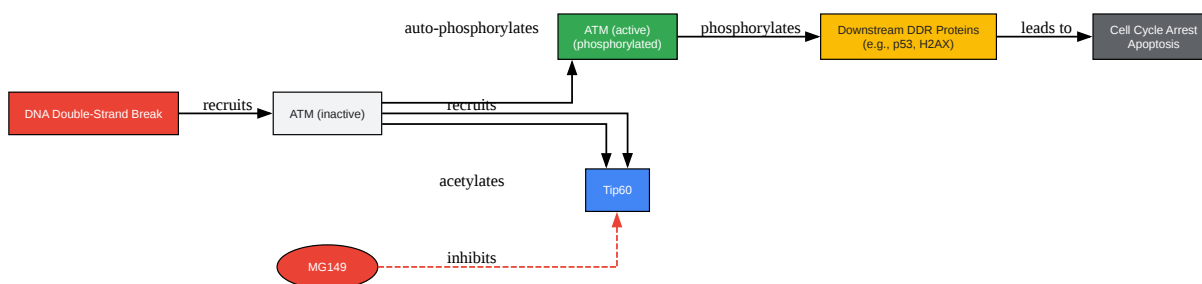

[Click to download full resolution via product page](#)

Caption: Tip60's role in the DNA damage response pathway.

Tip60-p300 Crosstalk in Treg Induction

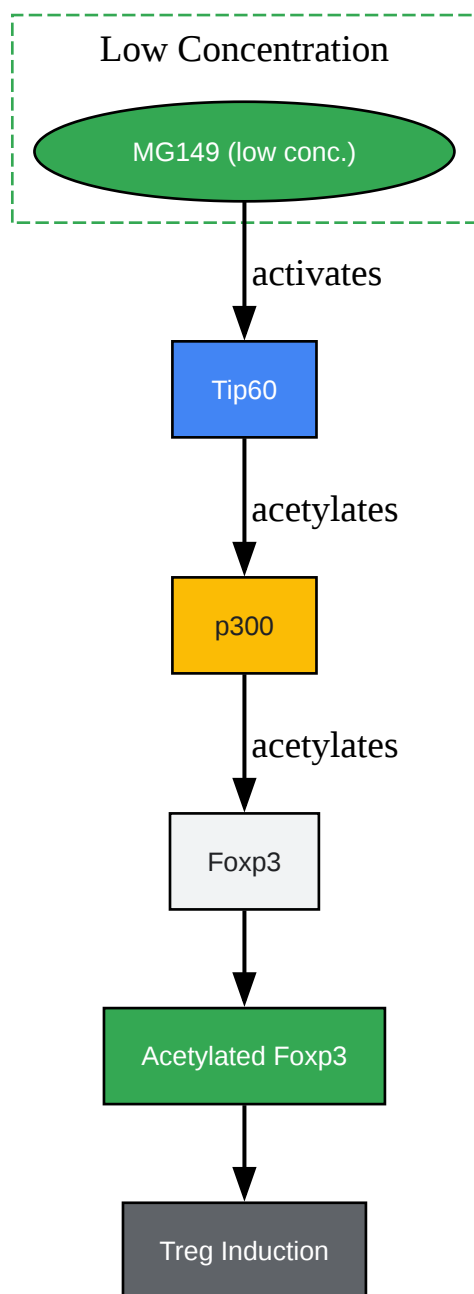

[Click to download full resolution via product page](#)

Caption: Tip60-p300 crosstalk in regulatory T cell induction.

Experimental Workflow for Cellular Tip60 Inhibition Assay



[Click to download full resolution via product page](#)

Caption: Workflow for Western blot analysis of Tip60 inhibition.

Conclusion

MG149 is a valuable tool for studying the biological functions of Tip60 and its related acetyltransferase, MOF. However, its characterization reveals a complex dose-dependent activity profile that researchers must consider. When compared to other inhibitors like NU9056 and TH1834, **MG149** exhibits a broader specificity profile. The choice of inhibitor will ultimately depend on the specific research question, the required potency, and the desired selectivity. This guide provides a foundational framework for making an informed decision when selecting and validating a Tip60 inhibitor for preclinical research.

Need Custom Synthesis?

BenchChem offers custom synthesis for rare earth carbides and specific isotopic labeling.

Email: info@benchchem.com or [Request Quote Online](#).

References

- 1. TIP60 enhances cisplatin resistance via regulating Δ Np63 α acetylation in SCC - PMC [[pmc.ncbi.nlm.nih.gov](https://pubmed.ncbi.nlm.nih.gov/)]
- 2. Pharmacological inhibition of the acetyltransferase Tip60 mitigates myocardial infarction injury - PMC [[pmc.ncbi.nlm.nih.gov](https://pubmed.ncbi.nlm.nih.gov/)]
- 3. Small-molecule TIP60 inhibitors enhance regulatory T cell induction through TIP60-P300 acetylation crosstalk - PMC [[pmc.ncbi.nlm.nih.gov](https://pubmed.ncbi.nlm.nih.gov/)]
- 4. [researchgate.net](https://www.researchgate.net/) [[researchgate.net](https://www.researchgate.net/)]

- [5. Characterisation of a Tip60 specific inhibitor, NU9056, in prostate cancer - PubMed \[pubmed.ncbi.nlm.nih.gov\]](#)
- [6. Characterisation of a Tip60 Specific Inhibitor, NU9056, in Prostate Cancer | PLOS One \[journals.plos.org\]](#)
- [7. medchemexpress.com \[medchemexpress.com\]](#)
- [8. Histone Acetyltransferase Activity Assay Kit \(Colorimetric\) \(ab65352\) is not available | Abcam \[abcam.com\]](#)
- [9. In vitro activity assays for MYST histone acetyltransferases and adaptation for high-throughput inhibitor screening - PMC \[pmc.ncbi.nlm.nih.gov\]](#)
- [10. origene.com \[origene.com\]](#)
- [11. Western Blot Procedure | Cell Signaling Technology \[cellsignal.com\]](#)
- [To cite this document: BenchChem. \[Validating MG149 Inhibition of Tip60: A Comparative Guide for Researchers\]. BenchChem, \[2026\]. \[Online PDF\]. Available at: \[https://www.benchchem.com/product/b15607072/docs#validating-mg149-inhibition-of-tip60-a-comparative-guide-for-researchers\]](#)

Disclaimer & Data Validity:

The information provided in this document is for Research Use Only (RUO) and is strictly not intended for diagnostic or therapeutic procedures. While BenchChem strives to provide accurate protocols, we make no warranties, express or implied, regarding the fitness of this product for every specific experimental setup.

Technical Support: The protocols provided are for reference purposes. Unsure if this reagent suits your experiment?

Need Industrial/Bulk Grade? [Request Custom Synthesis Quote](#)

BenchChem

Our mission is to be the trusted global source of essential and advanced chemicals, empowering scientists and researchers to drive progress in science and industry.

Contact

Address: 3281 E Guasti Rd

Ontario, CA 91761, United States

Phone: (601) 213-4426

Email: info@benchchem.com

[Contact our Ph.D. Support Team for a compatibility check](#)