

# Technical Support Center: Utilizing exo-IWR-1 as a Negative Control

**Author:** BenchChem Technical Support Team. **Date:** April 2026

## Compound of Interest

Compound Name: IWR-1  
Cat. No.: B15607926

[Get Quote](#)

This technical support center provides researchers, scientists, and drug development professionals with comprehensive guidance on the effective use of exo-IWR-1 as a negative control in experiments targeting the Wnt/ $\beta$ -catenin signaling pathway.

## Frequently Asked Questions (FAQs)

Q1: What is the mechanism of action of endo-IWR-1 and exo-IWR-1?

A1: Endo-IWR-1 is a well-established inhibitor of the canonical Wnt/ $\beta$ -catenin signaling pathway.[1] It functions by inhibiting the activity of Tankyrase-1 and -2 (TNKS1/2), which are poly(ADP-ribose) polymerases. This inhibition leads to the stabilization of Axin, a crucial component of the  $\beta$ -catenin destruction complex. An increase in stable Axin enhances the phosphorylation and subsequent proteasomal degradation of  $\beta$ -catenin, thereby preventing its accumulation and translocation to the nucleus to activate Wnt target genes. Exo-IWR-1 is a stereoisomer of endo-IWR-1 and is considered biologically inactive against the Wnt pathway.[1][2][3][4] Due to its structural similarity but lack of significant inhibitory activity, exo-IWR-1 serves as an ideal negative control to ensure that the observed effects are specific to the inhibition of the Wnt pathway by endo-IWR-1 and not due to off-target effects of the chemical scaffold.

Q2: How significant is the difference in activity between endo-IWR-1 and exo-IWR-1?

A2: Exo-**IWR-1** is significantly less active than endo-**IWR-1**. Studies have shown that exo-**IWR-1** is approximately 25-fold less active in inhibiting the Wnt/ $\beta$ -catenin pathway.[4] This substantial difference in activity is critical for its function as a negative control.

Q3: What is the recommended concentration range for using exo-**IWR-1** as a negative control?

A3: As a general principle, exo-**IWR-1** should be used at the same concentration as its active counterpart, endo-**IWR-1**. A typical concentration for endo-**IWR-1** in cell culture experiments ranges from 1  $\mu$ M to 10  $\mu$ M. Therefore, using exo-**IWR-1** in this same range is recommended to provide a robust control for any potential non-specific effects.

Q4: Can exo-**IWR-1** have any unexpected effects in my experiments?

A4: While exo-**IWR-1** is considered inactive against the Wnt pathway, it is crucial to remember that no chemical compound is entirely inert. At high concentrations, there is a possibility of off-target effects unrelated to Wnt signaling. It is essential to include proper vehicle controls (e.g., DMSO) and to carefully observe the cellular phenotype in the exo-**IWR-1** treated group for any unexpected changes that are distinct from the vehicle control.

## Troubleshooting Guide

Problem	Possible Cause	Suggested Solution
Unexpected activity observed with exo-IWR-1 (e.g., changes in cell morphology, proliferation, or gene expression).	1. High Concentration: The concentration of exo-IWR-1 may be too high, leading to off-target effects. 2. Compound Purity: The purity of the exo-IWR-1 stock may be compromised. 3. Cell Line Sensitivity: The specific cell line being used might be unusually sensitive to the chemical backbone of the IWR compounds.	1. Perform a dose-response experiment with exo-IWR-1 to determine if the observed effect is concentration-dependent. Use the lowest effective concentration for endo-IWR-1 and match it for exo-IWR-1. 2. Verify the purity of your exo-IWR-1 stock using analytical methods if possible, or purchase from a reputable supplier. 3. Test another inactive control compound with a different chemical scaffold if available.
Precipitation of exo-IWR-1 in culture medium.	Solubility Issues: IWR compounds have limited solubility in aqueous solutions.	1. Ensure the final concentration of the solvent (e.g., DMSO) in the culture medium is low (typically <0.5%) and consistent across all experimental conditions. 2. Prepare fresh dilutions of exo-IWR-1 from a concentrated stock solution for each experiment. 3. Briefly vortex or sonicate the stock solution before dilution.
Inconsistent results between experiments.	1. Compound Degradation: Improper storage of exo-IWR-1 stock solutions. 2. Variability in Experimental Conditions: Inconsistent cell density, incubation times, or reagent concentrations.	1. Store stock solutions of exo-IWR-1 at -20°C or -80°C in small aliquots to avoid repeated freeze-thaw cycles. Protect from light. 2. Standardize all experimental parameters and ensure

consistency across all replicates and experiments.

## Quantitative Data Summary

The following table summarizes the comparative activity of endo-IWR-1 and exo-IWR-1.

Compound	Target	IC <sub>50</sub>	Key Findings
endo-IWR-1	Tankyrase 1/2	~180 nM (in a cell-based Wnt/ $\beta$ -catenin pathway reporter assay)[5]	Potently inhibits Wnt signaling, leading to the degradation of $\beta$ -catenin.
exo-IWR-1	(Inactive)	Not applicable	Approximately 25-fold less active than endo-IWR-1; serves as an effective negative control.[4]

## Experimental Protocols

### Protocol 1: Wnt/ $\beta$ -catenin Reporter Assay

This protocol describes a luciferase-based reporter assay to confirm the inhibitory activity of endo-IWR-1 and the inactivity of exo-IWR-1.

Materials:

- HEK293T cells (or other suitable cell line)
- TCF/LEF luciferase reporter plasmid (e.g., TOPFlash)
- Renilla luciferase plasmid (for normalization)
- Wnt3a conditioned media (or recombinant Wnt3a)
- endo-IWR-1

- **exo-IWR-1**
- DMSO (vehicle)
- Lipofectamine 2000 (or other transfection reagent)
- Dual-Luciferase Reporter Assay System
- Luminometer

#### Procedure:

- **Cell Seeding:** Seed HEK293T cells in a 96-well plate at a density that will result in 70-80% confluency at the time of transfection.
- **Transfection:** Co-transfect the cells with the TCF/LEF luciferase reporter and Renilla luciferase plasmids using a suitable transfection reagent according to the manufacturer's instructions.
- **Compound Treatment:** 24 hours post-transfection, replace the medium with fresh medium containing Wnt3a, and treat the cells with a dose-response of endo-**IWR-1**, exo-**IWR-1**, or DMSO vehicle control. A typical concentration range is 0.1 to 10  $\mu$ M.
- **Incubation:** Incubate the cells for 16-24 hours.
- **Luciferase Assay:** Lyse the cells and measure firefly and Renilla luciferase activity using a dual-luciferase reporter assay system and a luminometer.
- **Data Analysis:** Normalize the firefly luciferase activity to the Renilla luciferase activity for each well. The results should demonstrate a dose-dependent decrease in luciferase activity with endo-**IWR-1** treatment, while exo-**IWR-1** should show no significant effect compared to the vehicle control.

## Protocol 2: Western Blot for $\beta$ -catenin Levels

This protocol is designed to assess the effect of endo-**IWR-1** and exo-**IWR-1** on  $\beta$ -catenin protein levels.

## Materials:

- SW480 cells (or another cell line with active Wnt signaling)
- endo-**IWR-1**
- exo-**IWR-1**
- DMSO (vehicle)
- RIPA buffer with protease and phosphatase inhibitors
- Primary antibody against  $\beta$ -catenin
- Primary antibody against a loading control (e.g., GAPDH or  $\beta$ -actin)
- HRP-conjugated secondary antibody
- ECL substrate

## Procedure:

- Cell Seeding and Treatment: Seed SW480 cells in a 6-well plate. Once the cells reach 70-80% confluency, treat them with endo-**IWR-1** (e.g., 10  $\mu$ M), exo-**IWR-1** (e.g., 10  $\mu$ M), or DMSO for 6-24 hours.
- Cell Lysis: Wash the cells with ice-cold PBS and lyse them with RIPA buffer.
- Protein Quantification: Determine the protein concentration of each lysate using a BCA assay.
- Western Blotting:
  - Separate equal amounts of protein (20-30  $\mu$ g) on an SDS-PAGE gel.
  - Transfer the proteins to a PVDF membrane.
  - Block the membrane with 5% non-fat milk or BSA in TBST for 1 hour.

- Incubate the membrane with the primary anti- $\beta$ -catenin antibody overnight at 4°C.
- Wash the membrane and incubate with the HRP-conjugated secondary antibody for 1 hour at room temperature.
- Detect the signal using an ECL substrate.
- Strip the membrane and re-probe for the loading control.
- Data Analysis: Quantify the band intensities. A significant decrease in  $\beta$ -catenin levels should be observed in the endo-**IWR-1** treated cells, while the exo-**IWR-1** treated cells should show levels similar to the vehicle control.

## Visualizations

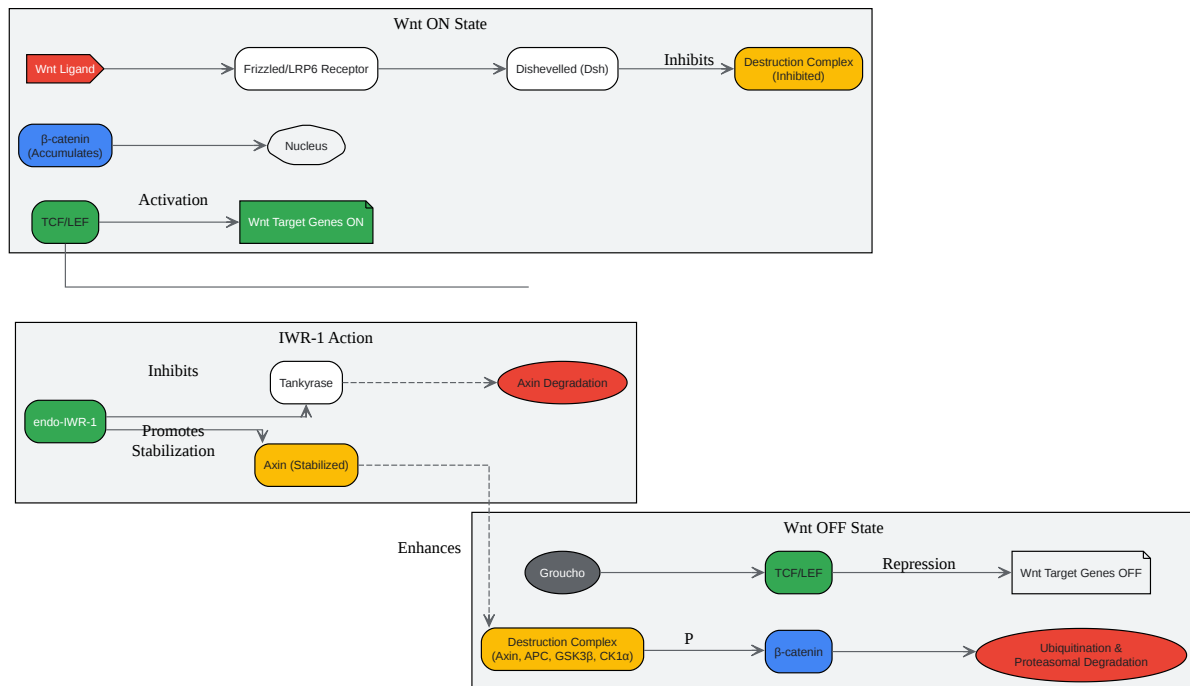

[Click to download full resolution via product page](#)

Caption: Canonical Wnt/β-catenin signaling pathway and the mechanism of **IWR-1** inhibition.

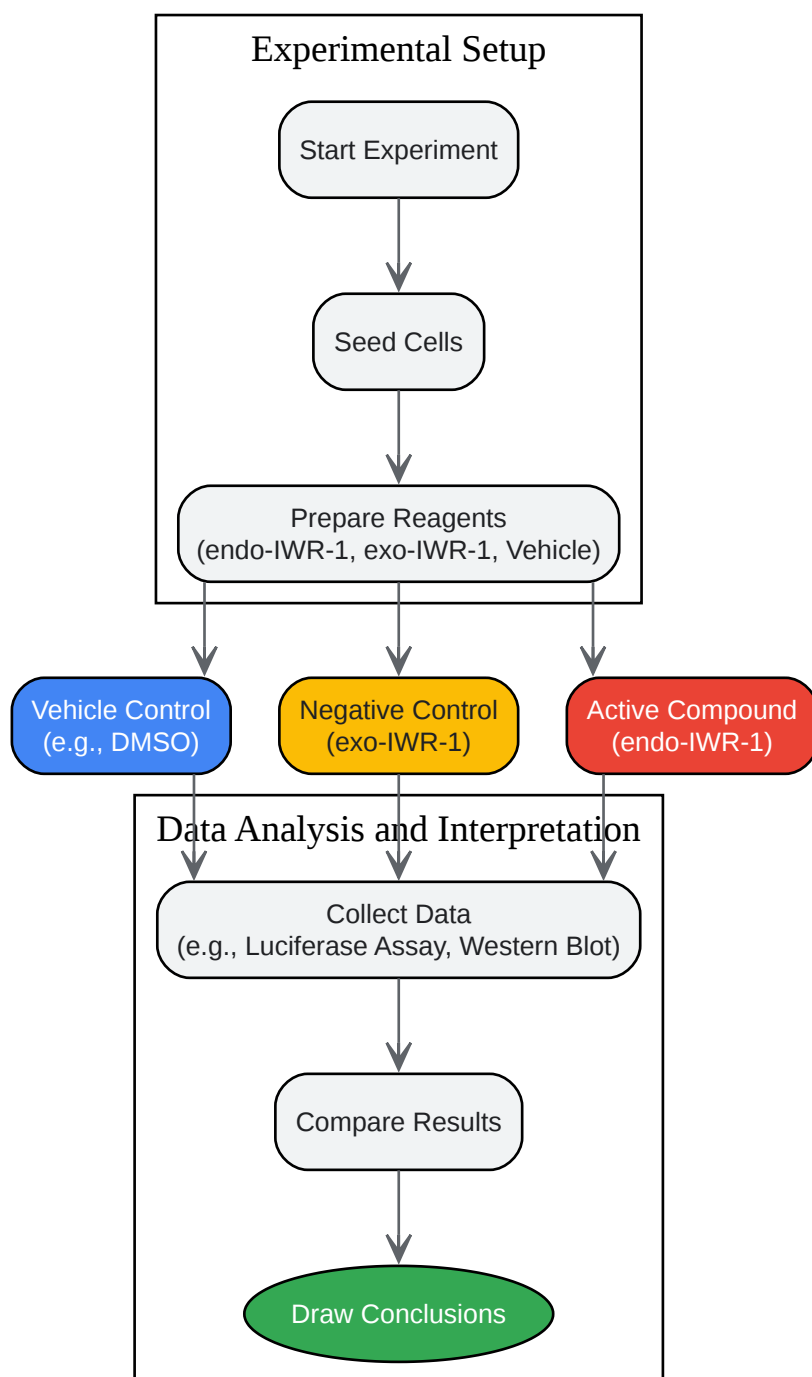

[Click to download full resolution via product page](#)

Caption: Logical workflow for using exo-IWR-1 as a negative control in experiments.

### Need Custom Synthesis?

BenchChem offers custom synthesis for rare earth carbides and specific isotopic labeling.

Email: [info@benchchem.com](mailto:info@benchchem.com) or [Request Quote Online](#).

## References

- [1. medchemexpress.com \[medchemexpress.com\]](https://www.medchemexpress.com)
- [2. Small molecule-mediated disruption of Wnt-dependent signaling in tissue regeneration and cancer - PMC \[pmc.ncbi.nlm.nih.gov\]](#)
- [3. exo-IWR-1 | 1127442-87-8 | Wnt/beta/catenin | MOLNOVA \[molnova.com\]](#)
- [4. exo-IWR-1 | Wnt/beta-catenin | TargetMol \[targetmol.com\]](#)
- [5. stemcell.com \[stemcell.com\]](https://www.stemcell.com)
- To cite this document: BenchChem. [Technical Support Center: Utilizing exo-IWR-1 as a Negative Control]. BenchChem, [2026]. [Online PDF]. Available at: [\[https://www.benchchem.com/product/b15607926/docs#technical-support-center-utilizing-exo-iwr-1-as-a-negative-control\]](https://www.benchchem.com/product/b15607926/docs#technical-support-center-utilizing-exo-iwr-1-as-a-negative-control)

---

### Disclaimer & Data Validity:

The information provided in this document is for Research Use Only (RUO) and is strictly not intended for diagnostic or therapeutic procedures. While BenchChem strives to provide accurate protocols, we make no warranties, express or implied, regarding the fitness of this product for every specific experimental setup.

**Technical Support:** The protocols provided are for reference purposes. Unsure if this reagent suits your experiment?

**Need Industrial/Bulk Grade?** [Request Custom Synthesis Quote](#)

# BenchChem

Our mission is to be the trusted global source of essential and advanced chemicals, empowering scientists and researchers to drive progress in science and industry.

## Contact

Address: 3281 E Guasti Rd

Ontario, CA 91761, United States

Phone: (601) 213-4426

Email: [info@benchchem.com](mailto:info@benchchem.com)

[Contact our Ph.D. Support Team for a compatibility check](#)