

Technical Support Center: Quality Control for CITCO in Research

Author: BenchChem Technical Support Team. **Date:** April 2026

Compound of Interest

Compound Name: Z-CITCO
Cat. No.: B15607392

[Get Quote](#)

For Researchers, Scientists, and Drug Development Professionals

This technical support center provides troubleshooting guides and frequently asked questions (FAQs) for the use of 6-(4-Chlorophenyl)imidazo[2,1-b][1,2]thiazole-5-carbaldehyde-O-(3,4-dichlorobenzyl)oxime (CITCO) in a research setting. CITCO is a widely used agonist for the human constitutive androstane receptor (CAR) and, as more recent research has shown, also an activator of the human pregnane X receptor (PXR). Understanding its dual activity and other key characteristics is crucial for obtaining reliable and reproducible experimental results.

Frequently Asked Questions (FAQs)

Q1: What is the primary mechanism of action of CITCO?

A1: CITCO is recognized as a potent agonist for the human constitutive androstane receptor (CAR, NR1I3).^[3] Upon binding, it induces the nuclear translocation of CAR, which then heterodimerizes with the retinoid X receptor (RXR). This complex binds to specific response elements on DNA to regulate the transcription of target genes, such as CYP2B6.^[3] Importantly, recent studies have demonstrated that CITCO also directly binds to and activates the human pregnane X receptor (PXR, NR1I2), making it a dual CAR/PXR agonist.^{[2][4]}

Q2: Is CITCO species-specific?

A2: Yes, CITCO exhibits significant species specificity. It is a potent activator of human CAR (hCAR) but not mouse CAR (mCAR).[2] Similarly, CITCO activates human PXR (hPXR) but not mouse PXR (mPXR).[2] This is a critical consideration when designing and interpreting studies using animal models. For in vivo studies investigating the effects of CITCO on human CAR, transgenic mice expressing hCAR are often used.

Q3: What are the known downstream target genes of CITCO?

A3: As a CAR and PXR agonist, CITCO upregulates the expression of genes involved in xenobiotic metabolism. The most well-characterized target genes include:

- CYP2B6: Primarily regulated by CAR.[3]
- CYP3A4: Regulated by both PXR and to a lesser extent, CAR.[2][5] The induction of these genes can be assessed at the mRNA level using quantitative real-time PCR (qPCR) or at the protein level via Western blotting or by measuring enzyme activity.

Q4: How should I prepare and store CITCO stock solutions?

A4: CITCO is soluble in dimethyl sulfoxide (DMSO) but not in water. For in vitro experiments, it is recommended to prepare a concentrated stock solution in anhydrous DMSO, for example, at 10 mM or 50 mM.[3] This stock solution should be stored at -20°C and desiccated to prevent moisture absorption by the DMSO.[3] It is advisable to aliquot the stock solution into smaller volumes to avoid repeated freeze-thaw cycles. The final concentration of DMSO in cell culture media should be kept low, typically below 0.5%, to minimize solvent-induced cytotoxicity.[6]

Troubleshooting Guide

Issue	Potential Cause	Recommended Solution
Inconsistent or no response to CITCO treatment	Incorrect species or cell model: CITCO is specific for human CAR and PXR.	Ensure you are using human cell lines (e.g., HepG2, HepaRG, primary human hepatocytes) or a relevant humanized animal model. CITCO will not be effective in wild-type mouse or rat models for studying CAR/PXR activation.[2]
Compound degradation: Improper storage or handling of CITCO or its solutions.	Prepare fresh stock solutions from powder. Aliquot stock solutions to minimize freeze-thaw cycles. Protect solutions from light.	
Suboptimal concentration: The concentration of CITCO may be too low to elicit a response or too high, causing cytotoxicity.	Perform a dose-response experiment to determine the optimal concentration for your specific cell type and endpoint. Refer to the quantitative data table below for typical effective concentrations.	
Dual receptor activation: The observed phenotype may be a composite of both CAR and PXR activation, leading to complex or unexpected results.	Use a PXR-specific antagonist, such as SPA70, to dissect the contribution of PXR activation. [2] Alternatively, use cell lines with CAR or PXR knocked out, if available.	
High background in luciferase reporter assays	Constitutive activity of CAR: CAR can have high basal activity in some cell lines, leading to a high background signal.	Consider using a CAR inverse agonist, such as PK11195, to reduce the basal activity in your assay system.[7]

Assay conditions: Plate color, reagent quality, or cell health can contribute to high background.	Use white, opaque-walled plates for luminescence assays to prevent well-to-well crosstalk. ^[8] Ensure luciferase reagents are fresh and properly prepared. Confirm cell viability.	
Variability between experimental replicates	Pipetting errors: Inaccurate pipetting, especially of small volumes of concentrated compounds.	Prepare a master mix of treatment media containing the final concentration of CITCO. Use calibrated pipettes.
Cell plating inconsistency: Uneven cell density across wells.	Ensure a homogenous cell suspension before plating and use consistent plating techniques.	
Edge effects in multi-well plates: Evaporation from wells on the edge of the plate can concentrate the compound and affect cell health.	Avoid using the outer wells of the plate for experimental conditions. Fill them with sterile PBS or media to maintain humidity.	
Unexpected off-target effects	Activation of other signaling pathways: While CITCO is reported to be selective for CAR/PXR over other nuclear receptors, high concentrations may lead to off-target effects.	Use the lowest effective concentration of CITCO. If off-target effects are suspected, consult the literature for known interactions and consider using alternative CAR/PXR agonists for comparison.

Quantitative Data Summary

The following table summarizes key quantitative data for CITCO from the literature. Note that these values can vary depending on the specific cell line, experimental conditions, and assay used.

Parameter	Value	Cell Line / System	Receptor	Reference
EC50	49 nM	CV-1 cells (luciferase reporter assay)	hCAR	[3]
EC50	0.82 μ M	HepG2 cells (CYP3A4-luciferase reporter)	hPXR	[2]
Solubility	50 mM (21.84 mg/mL)	DMSO	N/A	[3]
Recommended in vitro concentration range	0.1 μ M - 10 μ M	Primary human hepatocytes, HepG2, HepaRG	hCAR/hPXR	[2][5]

Experimental Protocols

Protocol 1: Luciferase Reporter Gene Assay for CAR/PXR Activation

This protocol outlines the general steps for assessing hCAR or hPXR activation by CITCO using a luciferase reporter assay in a human cell line (e.g., HepG2).

- **Cell Plating:** Seed cells in a 96-well, white, clear-bottom plate at a density that will result in 70-90% confluency at the time of the assay.
- **Transfection (if not using a stable cell line):** Co-transfect cells with an expression vector for hCAR or hPXR, a luciferase reporter plasmid containing response elements for the respective receptor (e.g., a CYP2B6 or CYP3A4 promoter-luciferase construct), and a control plasmid (e.g., Renilla luciferase) for normalization.
- **Treatment:** After 24 hours (or once cells have reached the desired confluency), replace the medium with fresh medium containing various concentrations of CITCO or a vehicle control

(e.g., 0.1% DMSO). It is recommended to perform a serial dilution to generate a dose-response curve.

- Incubation: Incubate the cells for 18-24 hours at 37°C in a CO2 incubator.
- Lysis: Wash the cells with PBS and then add a passive lysis buffer.
- Luciferase Assay: Measure the firefly and Renilla luciferase activities using a dual-luciferase reporter assay system according to the manufacturer's instructions on a luminometer.
- Data Analysis: Normalize the firefly luciferase activity to the Renilla luciferase activity to control for transfection efficiency and cell number. Plot the normalized luciferase activity against the CITCO concentration to generate a dose-response curve and calculate the EC50 value.

Protocol 2: qPCR Analysis of Target Gene Induction

This protocol describes how to measure the induction of CAR and PXR target genes (e.g., CYP2B6, CYP3A4) in response to CITCO treatment in primary human hepatocytes or other suitable human liver cell models.

- Cell Culture and Treatment: Plate primary human hepatocytes or other liver cells and allow them to acclimate. Treat the cells with the desired concentrations of CITCO or a vehicle control for 24-72 hours.
- RNA Isolation: Harvest the cells and isolate total RNA using a commercially available kit.
- RNA Quantification and Quality Control: Measure the concentration and purity of the isolated RNA using a spectrophotometer (e.g., NanoDrop).
- Reverse Transcription: Synthesize cDNA from the total RNA using a reverse transcription kit.
- Quantitative Real-Time PCR (qPCR): Perform qPCR using primers specific for your target genes (e.g., CYP2B6, CYP3A4) and a housekeeping gene (e.g., GAPDH, ACTB) for normalization.
- Data Analysis: Calculate the relative mRNA expression of the target genes using the $\Delta\Delta C_t$ method. The results are typically expressed as fold induction over the vehicle control.

Visualizations

CITCO Activation of CAR and PXR Signaling Pathways

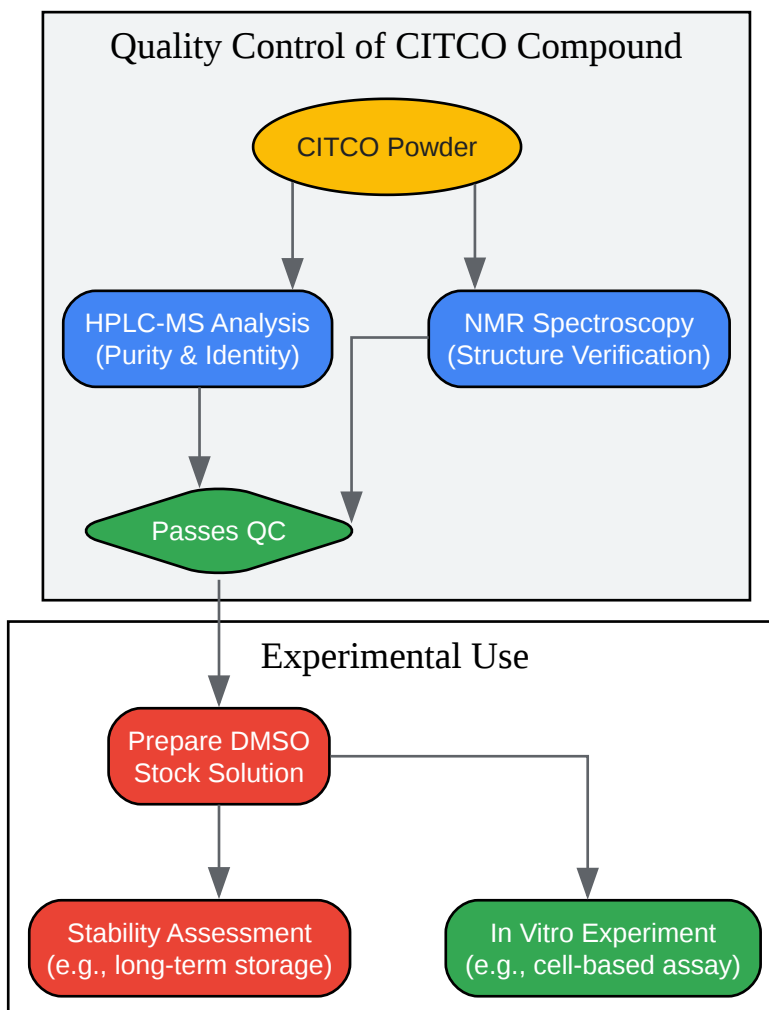
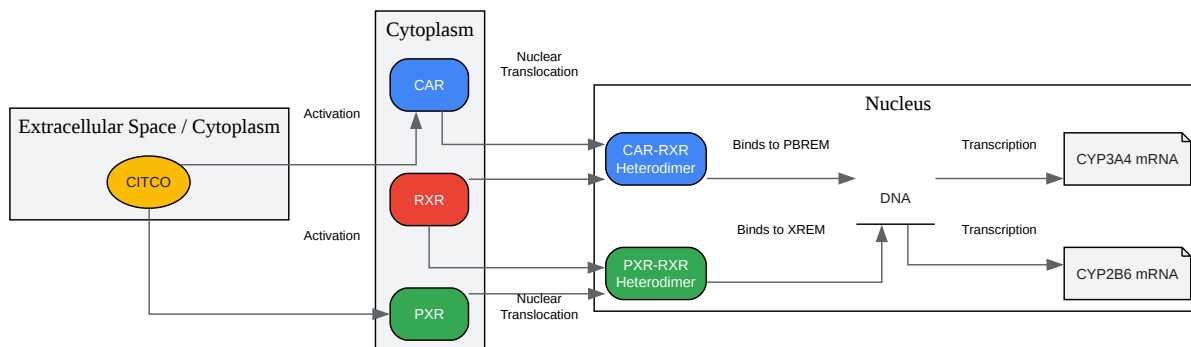

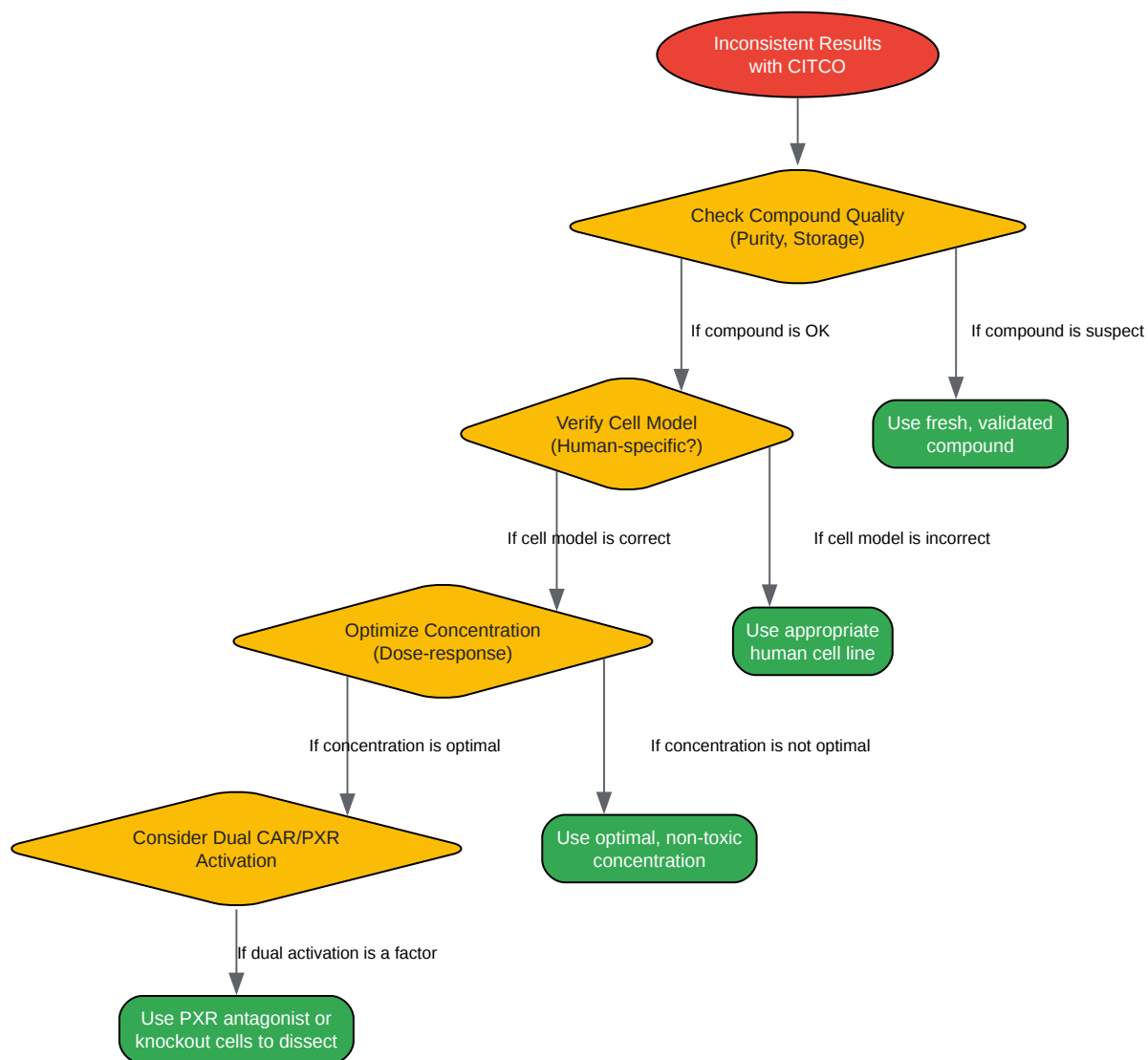

[Click to download full resolution via product page](#)

Need Custom Synthesis?

BenchChem offers custom synthesis for rare earth carbides and specific isotopic labeling.

Email: info@benchchem.com or [Request Quote Online](#).

References

- 1. goldbio.com [goldbio.com]
- 2. GitHub - pinczakko/GraphViz-Samples: A rather complex GraphViz DOT sample containing rather many hints for those interested in documenting his/her code via GraphViz DOT [github.com]
- 3. CITCO | Constitutive Androstane Receptor | Tocris Bioscience [tocris.com]
- 4. Standard Protocols for Characterising Primary and In Vitro-Generated Human Hepatocytes - PMC [pmc.ncbi.nlm.nih.gov]
- 5. Application of 1H and 13C NMR Fingerprinting as a Tool for the Authentication of Maltese Extra Virgin Olive Oil - PMC [pmc.ncbi.nlm.nih.gov]
- 6. resources.revvity.com [resources.revvity.com]
- 7. Quantitative High-throughput Luciferase Screening in Identifying CAR Modulators - PMC [pmc.ncbi.nlm.nih.gov]
- 8. bitesizebio.com [bitesizebio.com]
- To cite this document: BenchChem. [Technical Support Center: Quality Control for CITCO in Research]. BenchChem, [2026]. [Online PDF]. Available at: [<https://www.benchchem.com/product/b15607392/docs#technical-support-center-quality-control-for-citco-in-research>]

Disclaimer & Data Validity:

The information provided in this document is for Research Use Only (RUO) and is strictly not intended for diagnostic or therapeutic procedures. While BenchChem strives to provide accurate protocols, we make no warranties, express or implied, regarding the fitness of this product for every specific experimental setup.

Technical Support: The protocols provided are for reference purposes. Unsure if this reagent suits your experiment?

Need Industrial/Bulk Grade? [Request Custom Synthesis Quote](#)

BenchChem

Our mission is to be the trusted global source of essential and advanced chemicals, empowering scientists and researchers to drive progress in science and industry.

Contact

Address: 3281 E Guasti Rd
Ontario, CA 91761, United States
Phone: (601) 213-4426
Email: info@benchchem.com

[Contact our Ph.D. Support Team for a compatibility check](#)