

Symplostatin 1 Total Synthesis: A Detailed Protocol for Researchers

Author: BenchChem Technical Support Team. **Date:** April 2026

Compound of Interest

Compound Name: *Symplostatin 1*

Cat. No.: *B15607967*

[Get Quote](#)

For Immediate Release

This document provides a comprehensive overview and detailed protocol for the total synthesis of **Symplostatin 1**, a potent antimetabolic agent isolated from the marine cyanobacterium *Symploca hydroides*. As a structural analog of dolastatin 10, **Symplostatin 1** has garnered significant interest from the scientific community for its potential in cancer therapy. This application note is intended for researchers, scientists, and drug development professionals, offering a meticulously curated guide to the chemical synthesis of this complex natural product.

Introduction

Symplostatin 1 is a depsipeptide characterized by a unique sequence of four amino acids—dolavaline (Dov), valine (Val), dolaisoleucine (Dil), and dolaproine (Dap)—and a C-terminal 2-(thiazol-5-yl)ethanamine unit. Its potent cytotoxic activity, attributed to the inhibition of tubulin polymerization, makes it a compelling target for synthetic chemists and a promising candidate for further pharmacological evaluation.^{[1][2]} The total synthesis of **Symplostatin 1** presents numerous challenges, including the stereoselective construction of its unusual amino acid residues and the efficient formation of the macrocyclic structure. This protocol outlines a

convergent synthetic strategy, proceeding through the synthesis of key fragments followed by their assembly and final macrocyclization.

Retrosynthetic Analysis

A convergent retrosynthetic strategy is employed for the synthesis of **Symplostatin 1**. The macrocycle is disconnected at the amide bond between the N,N-dimethylisoleucine (DiM) and dolaproine (Dap) residues, revealing a linear precursor. This precursor is further broken down into two key fragments: the N-terminal tetrapeptide, DiM-Dov-Val-Dil-OH, and the C-terminal dipeptide unit containing dolaproine and the thiazole moiety. This approach allows for the parallel synthesis of complex fragments, enhancing the overall efficiency of the synthesis.

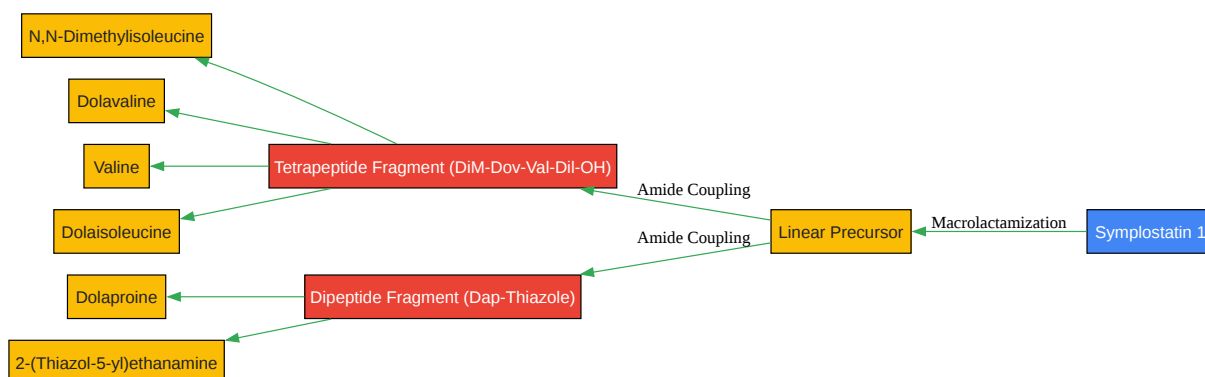

[Click to download full resolution via product page](#)

Caption: Retrosynthetic analysis of **Symplostatin 1**.

Experimental Protocols

This section provides detailed methodologies for the synthesis of the key fragments and the final assembly of **Symplostatin 1**.

Synthesis of Key Fragments

The synthesis of the unusual amino acids, dolavaline, dolaisoleucine, and dolaproine, requires stereoselective methods. The following protocols are based on established literature procedures for the synthesis of dolastatin 10 components.

1. Synthesis of Protected Dolavaline (Boc-Dov-OH)

The synthesis of dolavaline often starts from L-valine and involves the introduction of the N,N-dimethyl group and the unique side chain.

- Protocol:
 - N-methylation of L-valine methyl ester using formaldehyde and sodium cyanoborohydride.
 - Protection of the secondary amine with a Boc group.
 - Reduction of the ester to the corresponding aldehyde.
 - Stereoselective addition of a suitable nucleophile to the aldehyde to establish the correct stereochemistry of the side chain.
 - Oxidation of the resulting alcohol to the carboxylic acid.

2. Synthesis of Protected Dolaisoleucine (Boc-Dil-OH)

The synthesis of dolaisoleucine presents a significant stereochemical challenge with its three contiguous chiral centers. An asymmetric aldol reaction is a key step in establishing the desired stereochemistry.

- Protocol:
 - Preparation of the chiral N-acyl oxazolidinone derived from L-isoleucine.

- Asymmetric aldol condensation with a suitable electrophile to introduce the C2 and C3 stereocenters.
- Stereoselective methylation of the β -hydroxyl group.
- Cleavage of the chiral auxiliary to yield the protected dolaisoleucine.

3. Synthesis of Protected Dolaproine (Boc-Dap-OH)

The synthesis of the unique β -methoxy- γ -amino acid dolaproine is also achieved through a stereoselective aldol reaction.

- Protocol:
 - Preparation of the N-Boc-L-prolinal from N-Boc-L-proline.
 - Asymmetric aldol reaction between N-Boc-L-prolinal and a chiral propionate equivalent, often employing a boron enolate for high diastereoselectivity.^{[3][4][5][6][7]}
 - Methylation of the resulting β -hydroxy group.
 - Hydrolysis of the ester to afford the carboxylic acid.

4. Synthesis of the C-terminal Thiazole Moiety (2-(Thiazol-5-yl)ethanamine)

The C-terminal fragment can be synthesized from commercially available starting materials.

- Protocol:
 - Hantzsch thiazole synthesis using a suitable α -halo ketone and thioamide to construct the thiazole ring.
 - Functional group manipulation to introduce the ethylamine side chain at the C5 position of the thiazole. This can be achieved through various methods, such as a Wittig reaction followed by reduction and amination.

Assembly of Fragments and Macrocyclization

The synthesized fragments are coupled using standard peptide coupling reagents, followed by deprotection and macrocyclization to yield **Symplostatin 1**.

1. Synthesis of the Linear Precursor

- Protocol:
 - Couple the protected dolaproine (Boc-Dap-OH) with 2-(thiazol-5-yl)ethanamine using a peptide coupling reagent such as HATU or PyBOP in the presence of a tertiary amine base like DIPEA.
 - Deprotect the N-terminal Boc group of the resulting dipeptide using trifluoroacetic acid (TFA).
 - Sequentially couple the protected amino acids (Boc-Dil-OH, Boc-Val-OH, Boc-Dov-OH, and finally N,N-dimethylisoleucine) to the growing peptide chain, with an intervening Boc deprotection step after each coupling.

2. Macrolactamization

- Protocol:
 - Deprotect the N-terminal protecting group of the fully assembled linear precursor.
 - Deprotect the C-terminal ester to reveal the free carboxylic acid.
 - Perform the macrolactamization under high dilution conditions to favor intramolecular cyclization over intermolecular polymerization. Common reagents for this step include DPPA (diphenylphosphoryl azide) or using a carbodiimide-based coupling reagent in the presence of an additive like HOBt.[\[4\]](#)[\[8\]](#)

Quantitative Data

The following table summarizes the reported yields for key steps in the synthesis of dolastatin 10, which are expected to be comparable for the synthesis of **Symplostatin 1**.

Step	Reagents and Conditions	Yield (%)	Reference
Fragment Synthesis			
Boc-Dolaproine Synthesis	Asymmetric Aldol, Methylation, Hydrolysis	~60-70 (over several steps)	[3][5]
Boc-Dolaisoleucine Synthesis	Asymmetric Aldol, Methylation, Auxiliary Cleavage	~50-60 (over several steps)	
Fragment Coupling			
Dipeptide Formation	HATU, DIPEA, DMF	>85	[9]
Tetrapeptide Assembly	Sequential coupling and deprotection	~70-80 (per coupling)	[9]
Final Steps			
Macrocyclization	DPPA, NaHCO ₃ , DMF (high dilution)	~50-70	[4][8]

Experimental Workflow

The overall experimental workflow for the total synthesis of **Symplostatin 1** is depicted in the following diagram.

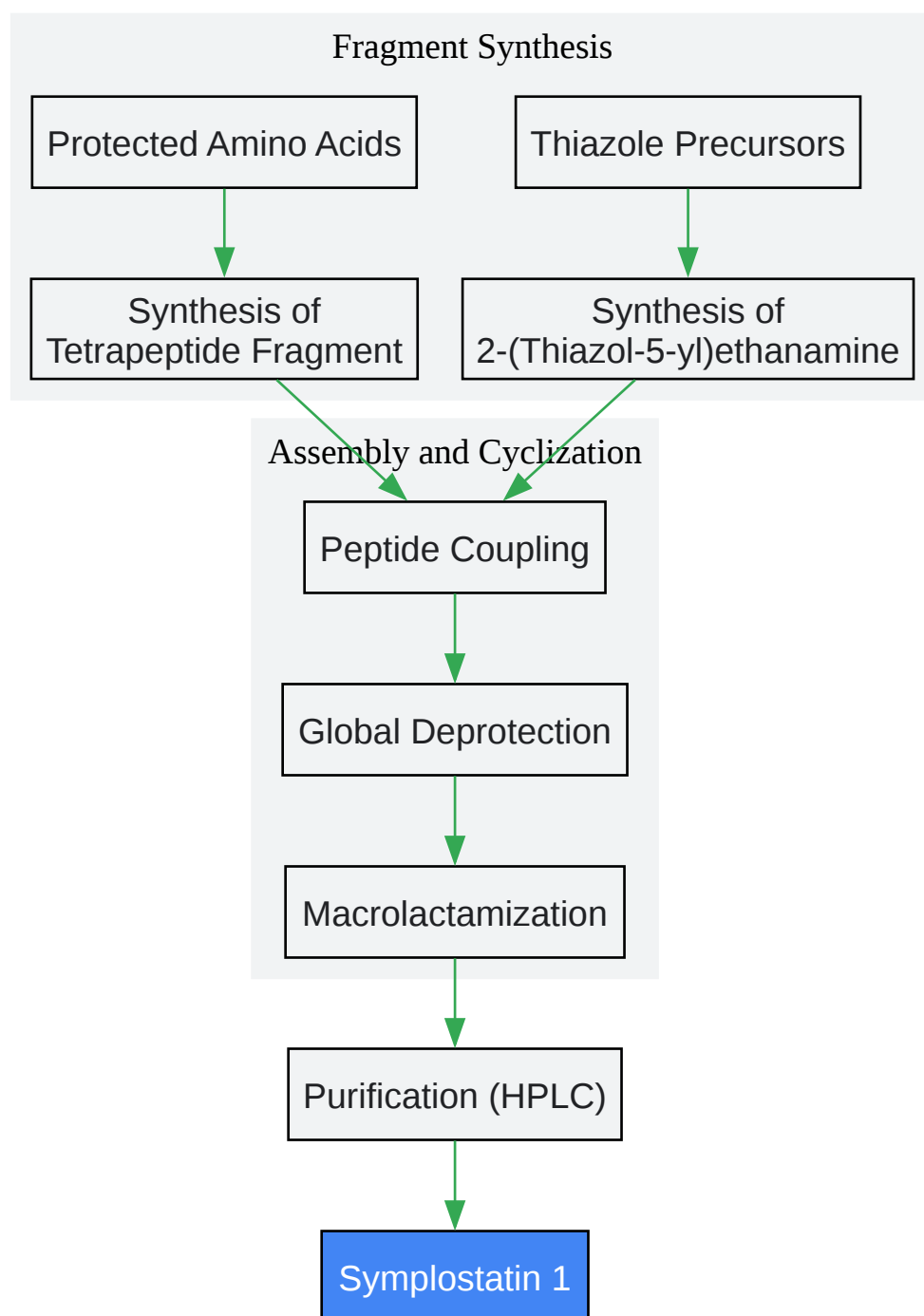

[Click to download full resolution via product page](#)

Caption: Overall workflow for the total synthesis of **Symplostatin 1**.

Conclusion

The total synthesis of **Symplostatin 1** is a challenging but achievable endeavor that provides access to a potent antimitotic agent for further biological and pharmacological investigation. The convergent strategy outlined in this protocol, based on the well-established chemistry for dolastatin 10, offers an efficient route to this complex natural product. The detailed experimental procedures and compiled quantitative data serve as a valuable resource for researchers in the fields of organic synthesis, medicinal chemistry, and drug discovery.

Need Custom Synthesis?

BenchChem offers custom synthesis for rare earth carbides and specific isotopic labeling.

Email: info@benchchem.com or [Request Quote Online](#).

References

- [1. asu.elsevierpure.com](http://asu.elsevierpure.com) [asu.elsevierpure.com]
- [2. chemscene.com](http://chemscene.com) [chemscene.com]
- [3. benchchem.com](http://benchchem.com) [benchchem.com]
- [4. Synthesis and Evaluation of Linear and Macrocyclic Dolastatin 10 Analogues Containing Pyrrolidine Ring Modifications - PMC](#) [pmc.ncbi.nlm.nih.gov]
- [5. ペプチドカップリング試薬のセレクションガイド](#) [sigmaaldrich.com]
- [6. Antineoplastic agents 337. Synthesis of dolastatin 10 structural modifications - PubMed](#) [pubmed.ncbi.nlm.nih.gov]
- [7. bachem.com](http://bachem.com) [bachem.com]
- [8. pubs.acs.org](http://pubs.acs.org) [pubs.acs.org]
- [9. mdpi.com](http://mdpi.com) [mdpi.com]
- To cite this document: BenchChem. [Symplostatin 1 Total Synthesis: A Detailed Protocol for Researchers]. BenchChem, [2026]. [Online PDF]. Available at: [<https://www.benchchem.com/product/b15607967/docs#symplostatin-1-total-synthesis-a-detailed-protocol-for-researchers>]

Disclaimer & Data Validity:

The information provided in this document is for Research Use Only (RUO) and is strictly not intended for diagnostic or therapeutic procedures. While BenchChem strives to provide accurate protocols, we make no warranties, express or implied, regarding the fitness of this product for every specific experimental setup.

Technical Support: The protocols provided are for reference purposes. Unsure if this reagent suits your experiment?

Need Industrial/Bulk Grade? [Request Custom Synthesis Quote](#)

BenchChem

Our mission is to be the trusted global source of essential and advanced chemicals, empowering scientists and researchers to drive progress in science and industry.

Contact

Address: 3281 E Guasti Rd
Ontario, CA 91761, United States
Phone: (601) 213-4426
Email: info@benchchem.com

[Contact our Ph.D. Support Team for a compatibility check](#)