

# Foundational Research on PDK1 Activators: A Technical Guide

**Author:** BenchChem Technical Support Team. **Date:** April 2026

## Compound of Interest

Compound Name: PS48  
Cat. No.: B15607208

[Get Quote](#)

For Researchers, Scientists, and Drug Development Professionals

## Introduction

3-phosphoinositide-dependent protein kinase-1 (PDK1) is a master regulator kinase within the AGC kinase family, playing a pivotal role in intracellular signaling pathways that govern cell survival, proliferation, and metabolism. Its activation is a critical node in the PI3K/Akt signaling cascade, a pathway frequently dysregulated in diseases such as cancer and neurodegenerative disorders. While much of the therapeutic focus has been on the development of PDK1 inhibitors, there is growing interest in the foundational research of PDK1 activators. These molecules serve as invaluable tools for elucidating the downstream effects of PDK1 activation and hold therapeutic potential in conditions where this pathway is sub-optimally active, such as certain neurodegenerative diseases. This technical guide provides an in-depth overview of the core foundational research on PDK1 activators, summarizing quantitative data, detailing experimental protocols for their characterization, and visualizing key signaling pathways and workflows.

## PDK1 Signaling and $\alpha$ -Losteric Activation

PDK1 is a serine/threonine kinase that, upon activation of the PI3K pathway, is recruited to the plasma membrane through the binding of its pleckstrin homology (PH) domain to phosphatidylinositol (3,4,5)-trisphosphate (PIP3). This co-localization facilitates the phosphorylation and subsequent activation of downstream targets, most notably Akt. Small-molecule activators of PDK1 have been developed that function through an allosteric mechanism. These compounds bind to a regulatory pocket on the kinase domain known as the "PIF" (protein kinase C-related kinase 2-interacting fragment) or hydrophobic motif (HM) pocket. This binding event induces a conformational change that stabilizes the active state of PDK1, thereby enhancing its catalytic activity.[1][2]

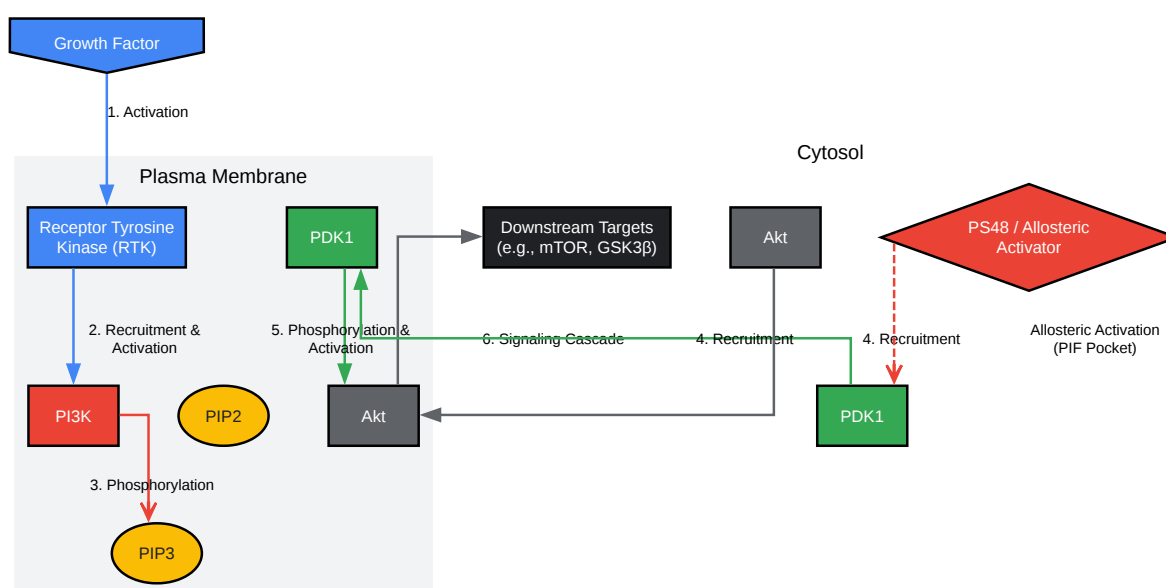

[Click to download full resolution via product page](#)

PDK1 signaling pathway and allosteric activation.

## Quantitative Data on PDK1 Activators

The following tables summarize the quantitative data for known small-molecule activators of PDK1. These compounds primarily act as allosteric activators by binding to the PIF pocket.

Table 1: Biochemical Potency of Allosteric PDK1 Activators

Compound	Activation Metric	Value ( $\mu\text{M}$ )	Assay Type	Reference
PS48	AC50	~25	Cell-Free Kinase Assay	[1]
PS48	Kd	10.3	Not Specified	
(R)-PS210	AC50	1.8	Cell-Free Kinase Assay	[1]
PS210	Kd	3	Not Specified	[1]
Compound 1	AC50	25	Cell-Free Kinase Assay	[3]
CRTh2 antagonist 3	EC50	2	Cell-Free Kinase Assay	[1]
CRTh2 antagonist 3	Kd	8.4	Not Specified	[1]

AC50 (Half-maximal activation concentration) and EC50 (Half-maximal effective concentration) are measures of potency. Kd (dissociation constant) is a measure of binding affinity. Lower values indicate higher potency or affinity.

## Experimental Protocols for Characterizing PDK1 Activators

A variety of biochemical assays can be employed to identify and characterize PDK1 activators. The following sections detail the methodologies for four common assay formats, adapted for activator screening.

### Radiometric Kinase Assay

This traditional method directly measures the enzymatic activity of PDK1 by quantifying the incorporation of a radiolabeled phosphate from [ $\gamma$ - $^{32}\text{P}$ ]ATP or [ $\gamma$ - $^{33}\text{P}$ ]ATP onto a substrate peptide.

Principle: An increase in the amount of radiolabeled phosphate transferred to the substrate in the presence of a test compound, compared to a vehicle control, indicates activation of PDK1.

Workflow:

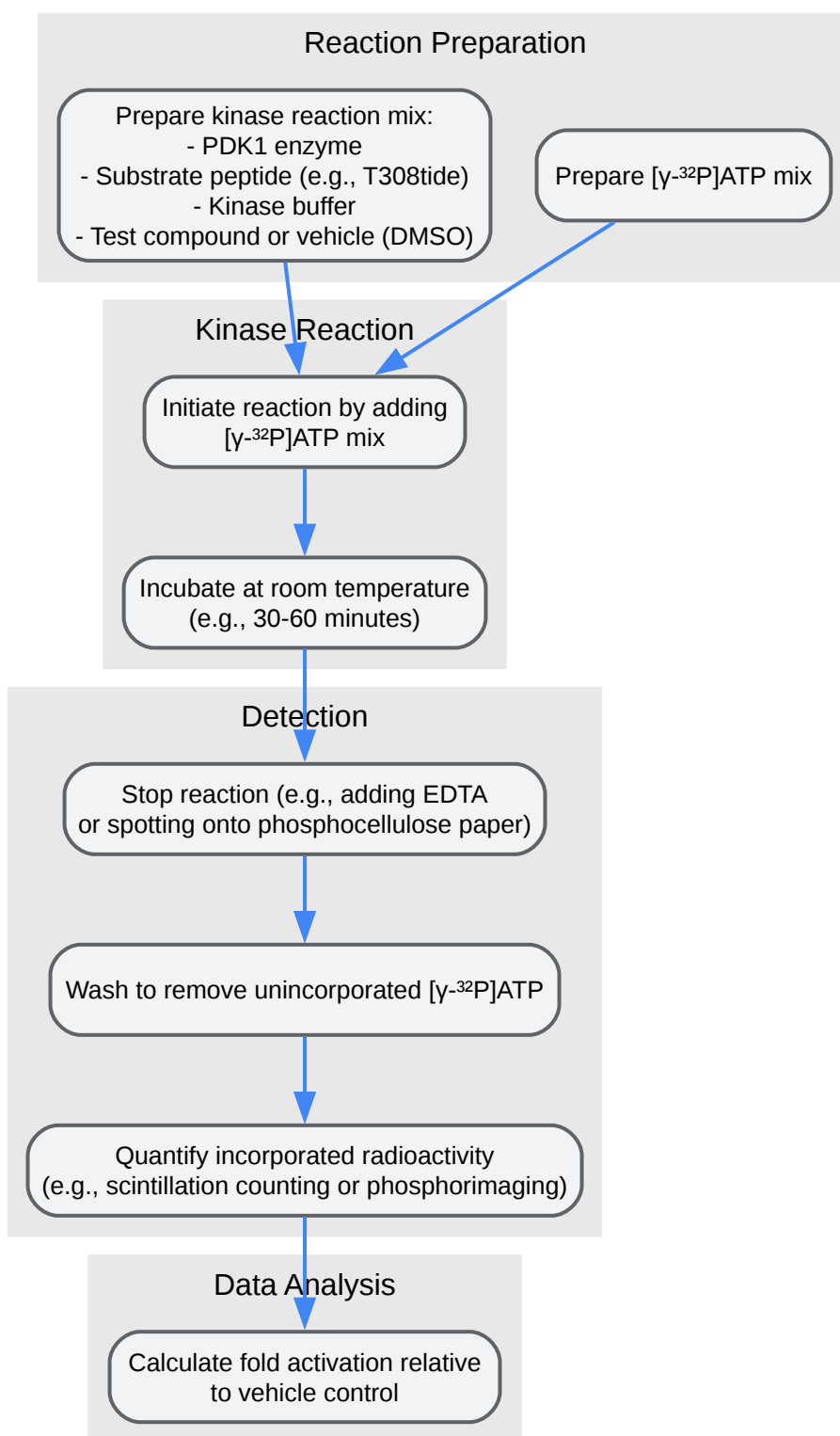

[Click to download full resolution via product page](#)

Workflow for a radiometric PDK1 activator assay.

## Detailed Protocol:

- Reaction Setup: In a microcentrifuge tube or microplate well, prepare the kinase reaction mixture containing:
  - Recombinant human PDK1 enzyme (e.g., 5-10 ng)
  - PDK1 substrate peptide (e.g., T308tide, 100  $\mu$ M)
  - Kinase reaction buffer (e.g., 40 mM Tris-HCl pH 7.5, 20 mM MgCl<sub>2</sub>, 0.1 mg/ml BSA, 50  $\mu$ M DTT)
  - Test compound at various concentrations (or DMSO as a vehicle control).
  - Incubate for 10 minutes at room temperature to allow for compound binding.
- Initiation: Start the reaction by adding [ $\gamma$ -<sup>32</sup>P]ATP (e.g., 10  $\mu$ M, with a specific activity of ~500 cpm/pmol).
- Incubation: Incubate the reaction for 30-60 minutes at room temperature. The incubation time should be optimized to ensure the reaction is in the linear range.
- Termination and Detection:
  - Stop the reaction by spotting a portion of the reaction mixture onto phosphocellulose paper (e.g., Whatman P81).
  - Wash the paper extensively (e.g., 3-4 times for 5-10 minutes each) in phosphoric acid (e.g., 0.75%) to remove unincorporated [ $\gamma$ -<sup>32</sup>P]ATP.
  - Rinse with acetone and let it air dry.
- Quantification: Measure the incorporated radioactivity using a scintillation counter or a phosphorimager.
- Data Analysis: Determine the amount of phosphate incorporated and calculate the fold activation by the test compound relative to the vehicle control. Plot the fold activation against the compound concentration to determine the AC50.

## Fluorescence Polarization (FP) Assay

This homogeneous assay is well-suited for high-throughput screening and measures the change in the rotational speed of a fluorescently labeled tracer molecule upon binding to an antibody.

Principle: In a competitive format for activator screening, PDK1 phosphorylates an unlabeled peptide substrate. This phosphorylated product then competes with a fluorescently labeled phosphopeptide tracer for binding to a phospho-specific antibody. Increased PDK1 activity leads to more unlabeled phosphopeptide, which displaces the tracer from the antibody, resulting in a decrease in fluorescence polarization.

Workflow:

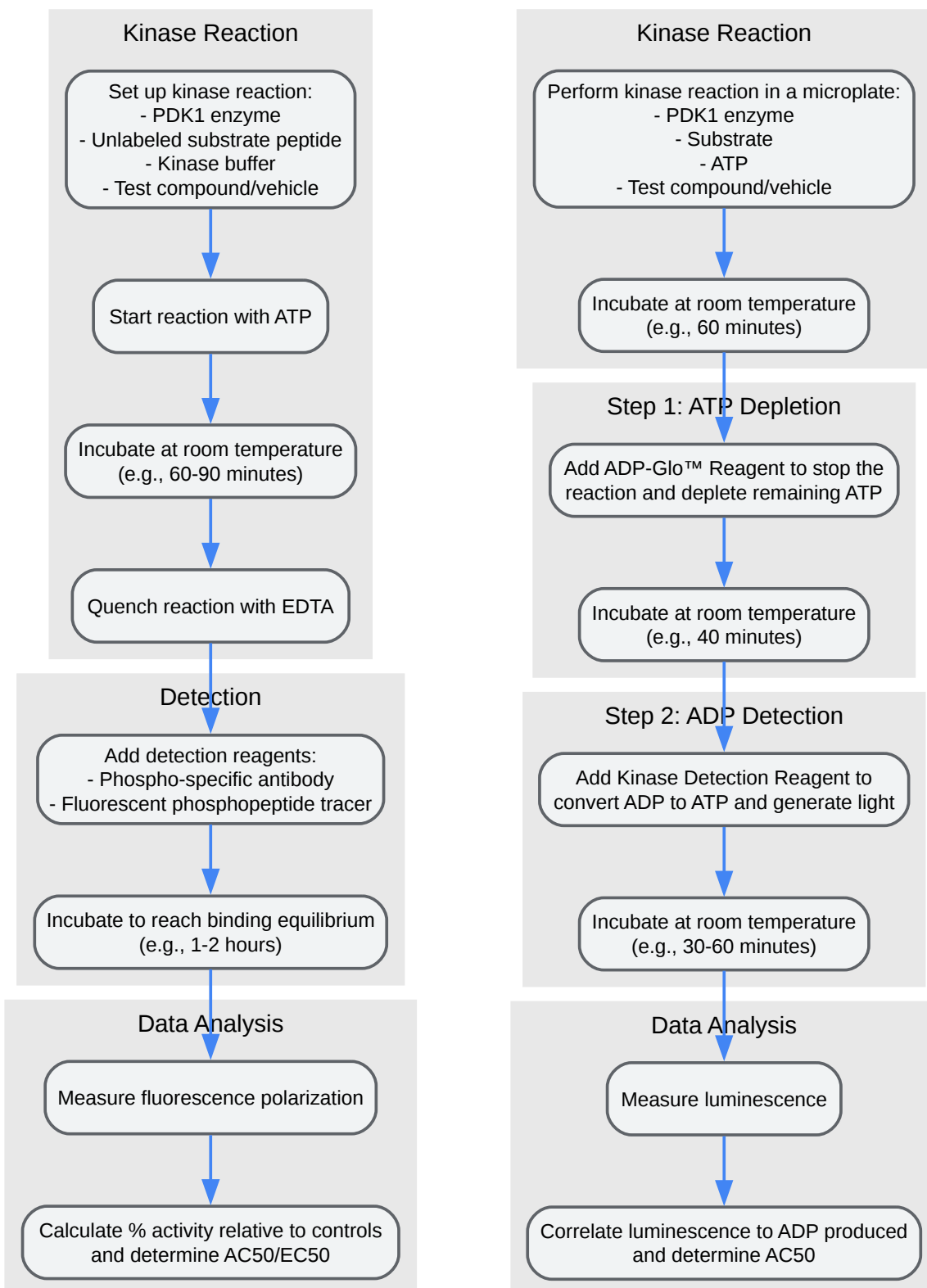

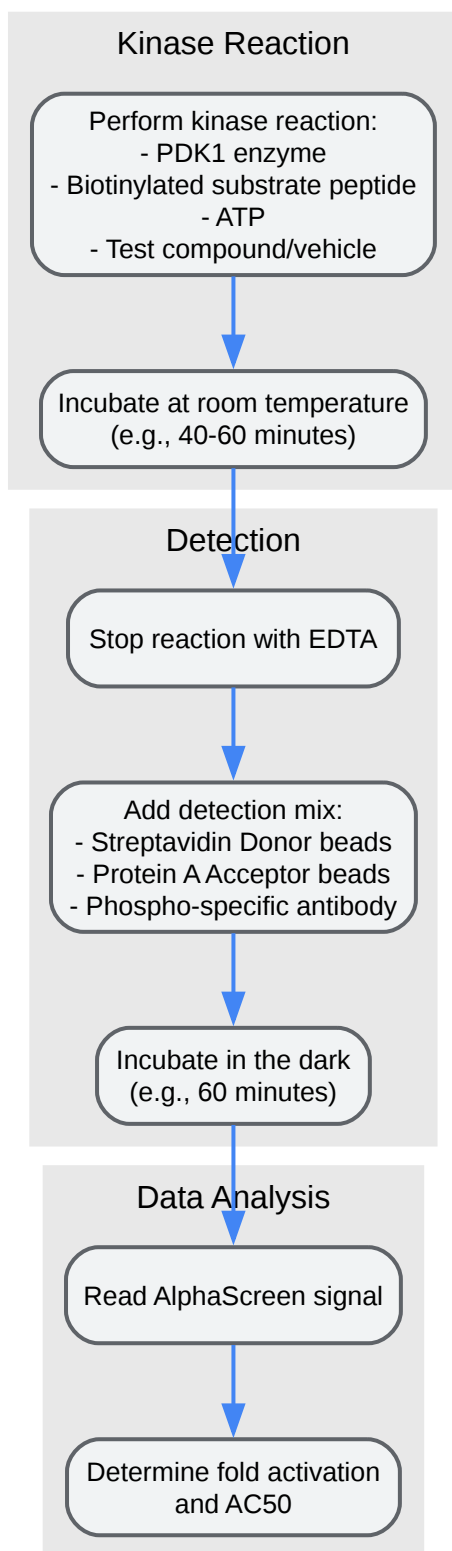

[Click to download full resolution via product page](#)

### Need Custom Synthesis?

BenchChem offers custom synthesis for rare earth carbides and specific isotopic labeling.

Email: [info@benchchem.com](mailto:info@benchchem.com) or [Request Quote Online](#).

## References

- [1. benchchem.com \[benchchem.com\]](https://www.benchchem.com)
- [2. benchchem.com \[benchchem.com\]](https://www.benchchem.com)
- [3. Allosteric activation of the protein kinase PDK1 with low molecular weight compounds - PMC \[pmc.ncbi.nlm.nih.gov\]](https://pubmed.ncbi.nlm.nih.gov/)
- To cite this document: BenchChem. [Foundational Research on PDK1 Activators: A Technical Guide]. BenchChem, [2026]. [Online PDF]. Available at: [\[https://www.benchchem.com/product/b15607208/docs#foundational-research-on-pdk1-activators-a-technical-guide\]](https://www.benchchem.com/product/b15607208/docs#foundational-research-on-pdk1-activators-a-technical-guide)

---

### Disclaimer & Data Validity:

The information provided in this document is for Research Use Only (RUO) and is strictly not intended for diagnostic or therapeutic procedures. While BenchChem strives to provide accurate protocols, we make no warranties, express or implied, regarding the fitness of this product for every specific experimental setup.

**Technical Support:** The protocols provided are for reference purposes. Unsure if this reagent suits your experiment?

**Need Industrial/Bulk Grade?** [Request Custom Synthesis Quote](#)

# BenchChem

Our mission is to be the trusted global source of essential and advanced chemicals, empowering scientists and researchers to drive progress in science and industry.

## Contact

Address: 3281 E Guasti Rd

Ontario, CA 91761, United States

Phone: (601) 213-4426

Email: [info@benchchem.com](mailto:info@benchchem.com)

[Contact our Ph.D. Support Team for a compatibility check](#)