

refining 10Panx dosage for specific animal models

Author: BenchChem Technical Support Team. **Date:** April 2026

Compound of Interest

Compound Name: 10Panx
Cat. No.: B15606058

[Get Quote](#)

Technical Support Center: 10Panx

This guide provides technical support for researchers utilizing **10Panx**, a mimetic peptide inhibitor of Pannexin-1 (Panx1) channels.^{[1][2][3][4]} It offers troubleshooting advice, frequently asked questions, and detailed protocols to facilitate the effective use of **10Panx** in various animal models.

Troubleshooting Guide

This section addresses common issues that may arise during experiments with **10Panx**.

Issue	Potential Cause	Recommended Solution
<p>Precipitation of 10Panx in solution</p>	<p>- Improper solvent: 10Panx has specific solubility characteristics.[4][5][6]- Incorrect storage: Stock solutions may not be stable for long periods at certain temperatures.[1][5]</p>	<p>- Solubility: 10Panx is soluble in water (up to 1 mg/ml or >10 mM) and DMSO (up to 50 mM).[1][6] For in vivo use, co-solvents like PEG300, Tween-80, or corn oil may be necessary.[5] Always prepare fresh working solutions for in vivo experiments.[5]- Storage: Store lyophilized peptide at -20°C or -80°C.[1] Store stock solutions in aliquots at -80°C for up to 6 months or at -20°C for up to 1 month.[5]</p>
<p>Lack of expected biological effect</p>	<p>- Suboptimal dosage: The effective dose can vary significantly between animal models and disease states.- Peptide degradation: Peptides can be susceptible to proteolysis, especially in vivo.[7]- Incorrect administration route: The route of administration can impact bioavailability and target engagement.</p>	<p>- Dosage Optimization: Perform a dose-response study to determine the optimal concentration for your specific model. Refer to the dosage table below for starting points from published studies.- Peptide Stability: The half-life of 10Panx in human plasma is very short (less than 3 minutes).[7] Consider more frequent dosing or a different administration route (e.g., intrathecal for CNS targets) to maintain effective concentrations.- Administration Route: For central nervous system applications, intrathecal injection has been shown to be effective.[5] For systemic effects,</p>

		intraperitoneal or intravenous routes may be appropriate, but stability should be considered.
Inconsistent results between experiments	<ul style="list-style-type: none"> - Variability in solution preparation: Freshly prepared solutions are recommended for each experiment.[5]- Presence of Trifluoroacetic acid (TFA): TFA from the purification process can be present and may affect sensitive assays.[3] 	<ul style="list-style-type: none"> - Standardize Protocols: Ensure consistent preparation of 10Panx solutions for every experiment. Use a vortex or sonication if necessary to ensure complete dissolution. [5]- Consider TFA Content: For highly sensitive experiments, be aware of the potential for TFA to interfere.[3]
Observed off-target effects	<ul style="list-style-type: none"> - High dosage: Supratherapeutic doses can lead to non-specific effects.- Model-specific sensitivity: The animal model may have unique sensitivities. 	<ul style="list-style-type: none"> - Dose Reduction: Lower the dose to the minimum effective concentration determined in your dose-response studies.- Control Experiments: Include appropriate vehicle controls and consider using a scrambled peptide control to ensure the observed effects are specific to Panx1 inhibition.

Frequently Asked Questions (FAQs)

Q1: What is **10Panx** and how does it work?

A1: **10Panx** is a synthetic decapeptide (sequence: WRQAAFVDSY) that acts as a competitive inhibitor of Pannexin-1 (Panx1) channels.[3][5] Panx1 channels are pores on the cell surface that open in response to various pathological signals, allowing the release of molecules like ATP.[8][9] This ATP release can trigger downstream inflammatory signaling pathways, such as the activation of the P2X7 receptor and the NLRP3 inflammasome.[5][8] By blocking the Panx1 channel, **10Panx** inhibits this ATP release, thereby reducing inflammation and cell death.[5]

Q2: What is the primary application of **10Panx** in animal models?

A2: **10Panx** is primarily used in research to study the role of Panx1 channels in various diseases. It has been utilized in animal models of neuropathic pain, inflammatory bowel disease, cerebral ischemia, and drug-induced hepatotoxicity.[3][5][7][10]

Q3: How should I prepare **10Panx** for in vivo administration?

A3: The preparation depends on the route of administration. For a stock solution, you can dissolve **10Panx** in sterile water or DMSO.[1][6] For in vivo working solutions, it is recommended to prepare them fresh on the day of use.[5] A common vehicle for systemic administration involves a mixture of DMSO, PEG300, Tween-80, and saline.[5] For example, a working solution can be prepared by adding a DMSO stock solution to PEG300, mixing, then adding Tween-80, mixing again, and finally adding saline to the desired volume.[5] Another option for systemic delivery is a formulation with corn oil.[5]

Q4: What are some typical dosages of **10Panx** used in animal models?

A4: Dosages can vary widely. For instance, in a rat model of neuropathic pain, a single intrathecal injection of 300 μ M **10Panx** was shown to be effective.[5] The optimal dose should be determined empirically for your specific application.

Quantitative Data Summary

The following table summarizes reported dosages and concentrations of **10Panx** from various studies. Note that concentrations for in vitro studies are often higher than what might be achievable systemically in vivo.

Application	Animal Model/Cell Type	Dosage/Concentration	Route of Administration	Reference
Neuropathic Pain	Rat	300 μ M	Intrathecal	[5]
Enteric Glial Cell Apoptosis	Cell Culture	50 μ M	In vitro	[5]
ATP Release from Red Blood Cells	Human Red Blood Cells	200 μ M	In vitro	[1]
Cerebral Ischemia	Rat	Not specified	Not specified	[10]

Experimental Protocols

Protocol: Intrathecal Administration of **10Panx** in a Rat Model of Neuropathic Pain

This protocol is a representative example for administering **10Panx** to target the spinal cord.

- Animal Preparation: Acclimate adult male Sprague-Dawley rats to the housing conditions for at least one week.
- **10Panx** Solution Preparation:
 - Prepare a stock solution of **10Panx** in sterile, nuclease-free water.
 - On the day of injection, dilute the stock solution with sterile saline to the final desired concentration (e.g., 300 μ M).
- Intrathecal Injection:
 - Briefly anesthetize the rat using isoflurane.
 - Perform a lumbar puncture between the L5 and L6 vertebrae.
 - Slowly inject the **10Panx** solution (typically 10-20 μ L) into the intrathecal space.

- Administer a vehicle control (saline) to a separate group of animals.
- Behavioral Testing:
 - Assess mechanical hyperalgesia (e.g., using von Frey filaments) at baseline and at various time points post-injection (e.g., 1, 2, 4, and 24 hours).
- Tissue Collection and Analysis:
 - At the end of the experiment, euthanize the animals and collect spinal cord tissue.
 - Analyze the tissue for markers of inflammation (e.g., IL-6) or neuronal activation.

Visualizations

Signaling Pathways and Experimental Workflow

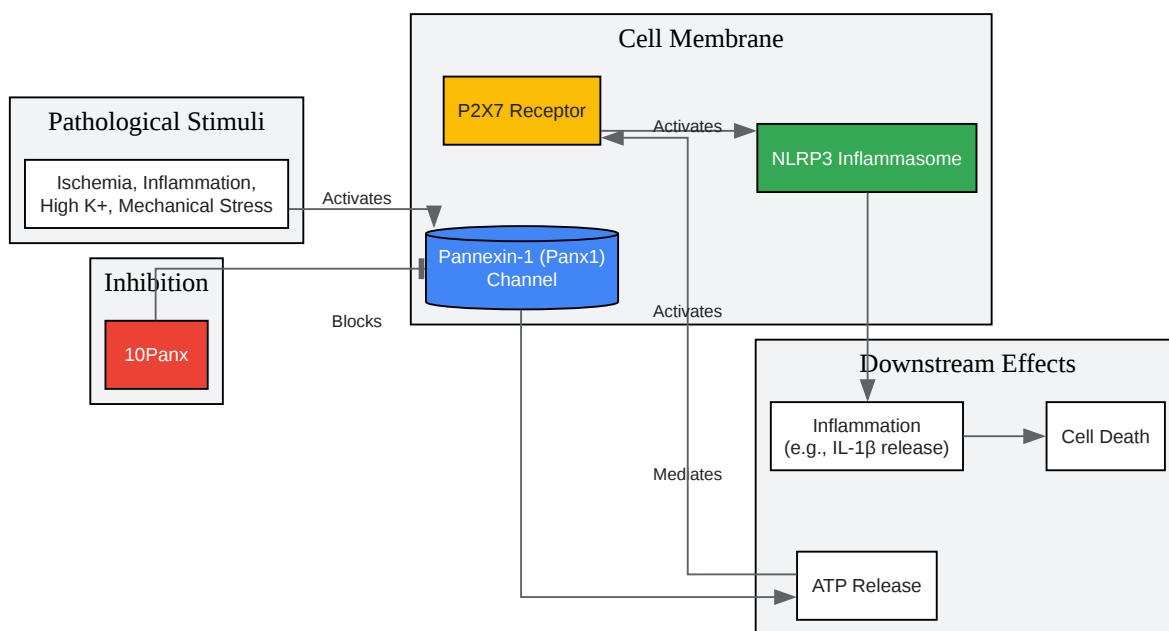

[Click to download full resolution via product page](#)

Caption: Mechanism of **10Panx** action on the Pannexin-1 signaling pathway.

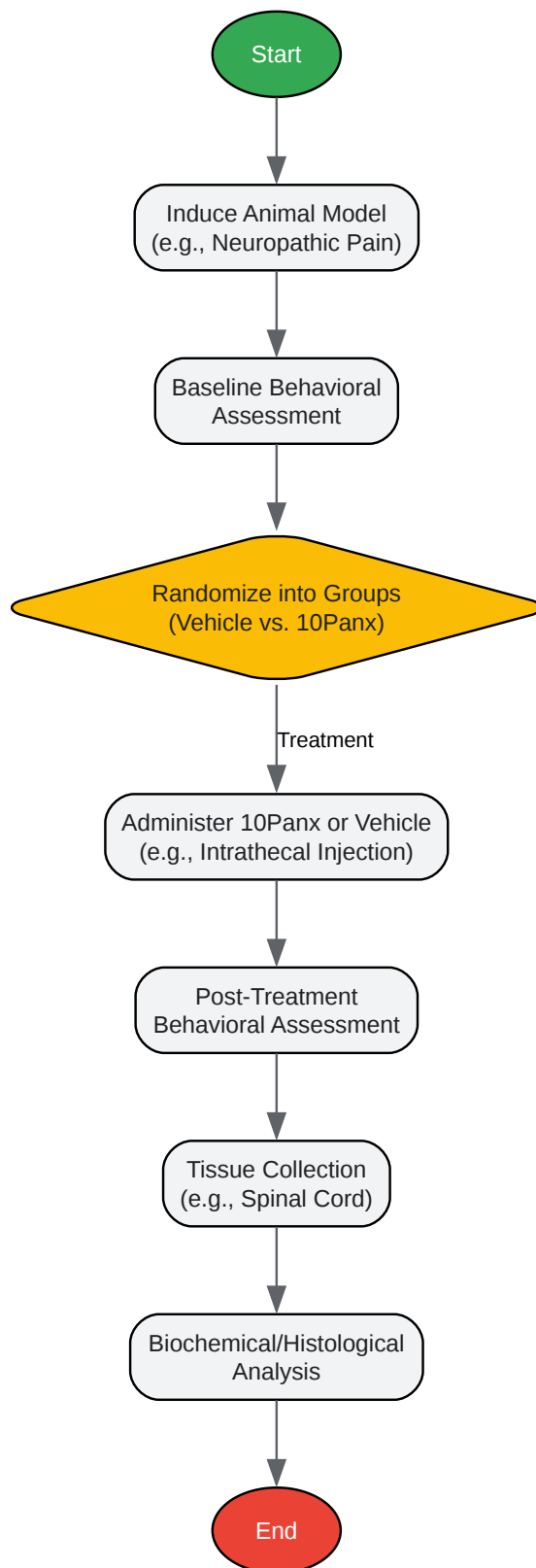

[Click to download full resolution via product page](#)

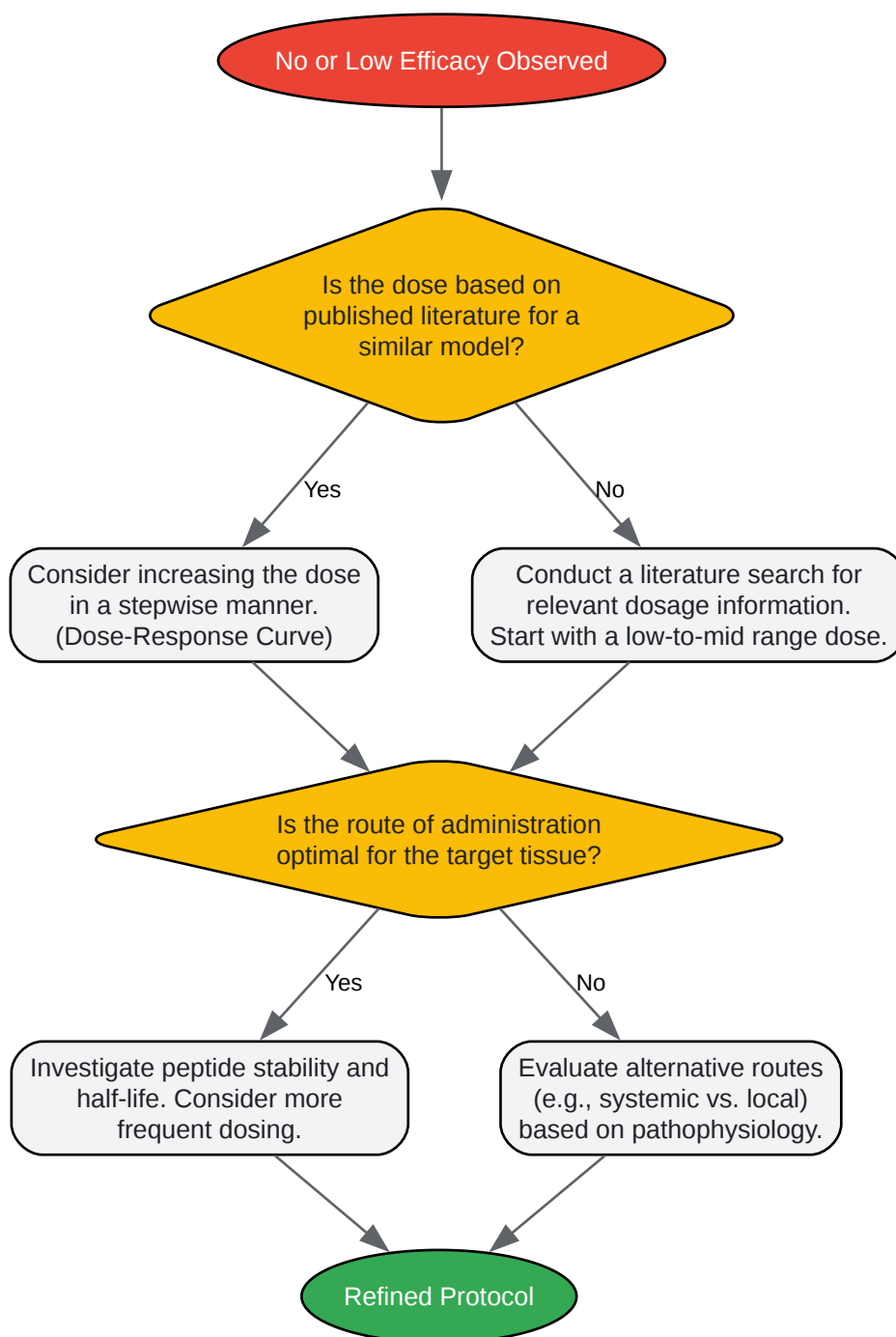
Caption: Experimental workflow for in vivo testing of **10Panx**.

[Click to download full resolution via product page](#)

Caption: Decision tree for refining **10Panx** dosage.

Need Custom Synthesis?

BenchChem offers custom synthesis for rare earth carbides and specific isotopic labeling.

Email: info@benchchem.com or [Request Quote Online](#).

References

- [1. apexbt.com \[apexbt.com\]](https://apexbt.com)
- [2. 10Panx | Gap Channels | Tocris Bioscience \[toocris.com\]](https://www.tocris.com)
- [3. 10Panx peptide \[novoprolabs.com\]](https://www.novoprolabs.com)
- [4. 10Panx | CAS:955091-53-9 | Panx-1 mimetic inhibitor | High Purity | Manufacturer BioCrick \[biocrick.com\]](https://www.biocrick.com)
- [5. medchemexpress.com \[medchemexpress.com\]](https://www.medchemexpress.com)
- [6. 10Panx, gap junction blocking peptide \(CAS 955091-53-9\) | Abcam \[abcam.com\]](https://www.abcam.com)
- [7. Structure-Based Design and Synthesis of Stapled 10Panx1 Analogues for Use in Cardiovascular Inflammatory Diseases - PMC \[pmc.ncbi.nlm.nih.gov\]](https://pubmed.ncbi.nlm.nih.gov)
- [8. Pannexin1 as mediator of inflammation and cell death - PMC \[pmc.ncbi.nlm.nih.gov\]](https://pubmed.ncbi.nlm.nih.gov)
- [9. Mechanisms of Pannexin 1 \(PANX1\) Channel Mechanosensitivity and Its Pathological Roles \[mdpi.com\]](https://www.mdpi.com)
- [10. Pannexin1 Channel Inhibitor \(10panx\) Protects Against Transient Focal Cerebral Ischemic Injury by Inhibiting RIP3 Expression and Inflammatory Response in Rats - PubMed \[pubmed.ncbi.nlm.nih.gov\]](https://pubmed.ncbi.nlm.nih.gov)
- To cite this document: BenchChem. [refining 10Panx dosage for specific animal models]. BenchChem, [2026]. [Online PDF]. Available at: [\[https://www.benchchem.com/product/b15606058/docs#refining-10panx-dosage-for-specific-animal-models\]](https://www.benchchem.com/product/b15606058/docs#refining-10panx-dosage-for-specific-animal-models)

Disclaimer & Data Validity:

The information provided in this document is for Research Use Only (RUO) and is strictly not intended for diagnostic or therapeutic procedures. While BenchChem strives to provide accurate protocols, we make no warranties, express or implied, regarding the fitness of this product for every specific experimental setup.

Technical Support: The protocols provided are for reference purposes. Unsure if this reagent suits your experiment?

Need Industrial/Bulk Grade? [Request Custom Synthesis Quote](#)

BenchChem

Our mission is to be the trusted global source of essential and advanced chemicals, empowering scientists and researchers to drive progress in science and industry.

Contact

Address: 3281 E Guasti Rd

Ontario, CA 91761, United States

Phone: (601) 213-4426

Email: info@benchchem.com

[Contact our Ph.D. Support Team for a compatibility check](#)