

# challenges in using G-1 for long-term in vivo studies

**Author:** BenchChem Technical Support Team. **Date:** April 2026

## Compound of Interest

Compound Name: (3a*S*,4*R*,9*bR*)-G-1

Cat. No.: B15606099

[Get Quote](#)

## Technical Support Center: G-1 In Vivo Studies

This technical support center provides troubleshooting guidance and answers to frequently asked questions for researchers using the GPER-selective agonist G-1 in long-term in vivo studies.

### Frequently Asked Questions (FAQs)

Q1: What is G-1 and what is its primary mechanism of action? A1: G-1 is a selective agonist for the G protein-coupled estrogen receptor (GPER), also known as GPR30.[1] Unlike classical nuclear estrogen receptors (ER $\alpha$  and ER $\beta$ ), GPER is a seven-transmembrane receptor that mediates rapid, non-genomic estrogen signaling.[2][3] Activation of GPER by G-1 can trigger various downstream signaling cascades, including the transactivation of the epidermal growth factor receptor (EGFR) and subsequent activation of the ERK1/2 and PI3K/Akt pathways.[4][5] It can also stimulate cAMP production and mobilize intracellular calcium.[6][7]

Q2: What are the known off-target effects of G-1? A2: The most commonly reported off-target effect of G-1, particularly at high concentrations, is the disruption of microtubule structures.[1][7] This can lead to cytotoxicity and cytostatic effects independent of GPER activation.[7]

Researchers should be cautious when using high doses of G-1 and consider using GPER antagonists like G-36 to confirm that the observed effects are GPER-mediated.[1][7]

Q3: How stable is G-1 in vivo? A3: While specific long-term stability data for G-1 in various tissues is not extensively published, its fat-soluble nature and plasma membrane permeability are well-documented.[7] Like many small molecules, its in vivo stability and metabolism can be influenced by the animal model, administration route, and formulation. For long-term studies, it is crucial to prepare fresh formulations regularly and protect them from light and degradation.

Q4: Can G-1 be used for oral administration? A4: G-1 is a hydrophobic molecule, which can present challenges for aqueous solubility and oral bioavailability. Most in vivo studies have utilized intraperitoneal (i.p.) or subcutaneous (s.c.) injections. If oral administration is necessary, formulation with appropriate vehicles such as corn oil or solutions containing DMSO and Tween 80 may be required to improve solubility and absorption.[8] Pilot studies to determine the pharmacokinetic profile of the chosen oral formulation are highly recommended.

## Troubleshooting Guides

### Issue 1: High Variability or Lack of Reproducibility in Results

Potential Cause	Troubleshooting Step
Inconsistent Dosing	Ensure the G-1 formulation is homogenous before each administration. If using a suspension, vortex or sonicate thoroughly immediately before drawing each dose.[8]
Compound Degradation	Prepare fresh G-1 stock solutions and formulations regularly. Store stock solutions in small, single-use aliquots at -80°C to avoid repeated freeze-thaw cycles.[8] Protect all solutions from light.
Animal Stress/Health	Monitor animals closely for any signs of distress. Ensure consistent housing conditions, diet, and handling procedures across all experimental groups.
Biological Variability	Increase the number of animals per group to enhance statistical power. Ensure animals are properly randomized into treatment groups.

## Issue 2: Unexpected Toxicity or Animal Distress

Potential Cause	Troubleshooting Step
Vehicle Toxicity	High concentrations of solvents like DMSO can be toxic.[8] Reduce the concentration of DMSO to the lowest effective level (ideally <10% in the final injection volume). Always include a vehicle-only control group to assess the tolerability of the formulation.[8]
Off-Target Effects	The observed toxicity may be a GPER-independent, off-target effect of G-1, especially at higher doses.[1] Try reducing the dose. To confirm the effect is GPER-mediated, include a group treated with G-1 in combination with a GPER antagonist (e.g., G-36).[7]
Compound Precipitation	Poorly solubilized G-1 can precipitate upon injection, causing local irritation or embolism. Visually inspect the formulation for any precipitation before injection. If precipitation occurs, optimize the formulation by adjusting co-solvents or using a suspension-based vehicle. [8]
Rapid Administration	For intravenous injections, administer the solution slowly to avoid cardiac or respiratory distress.

### Issue 3: Observed Biological Effect is Not Blocked by GPER Antagonist

This scenario strongly suggests an off-target mechanism.

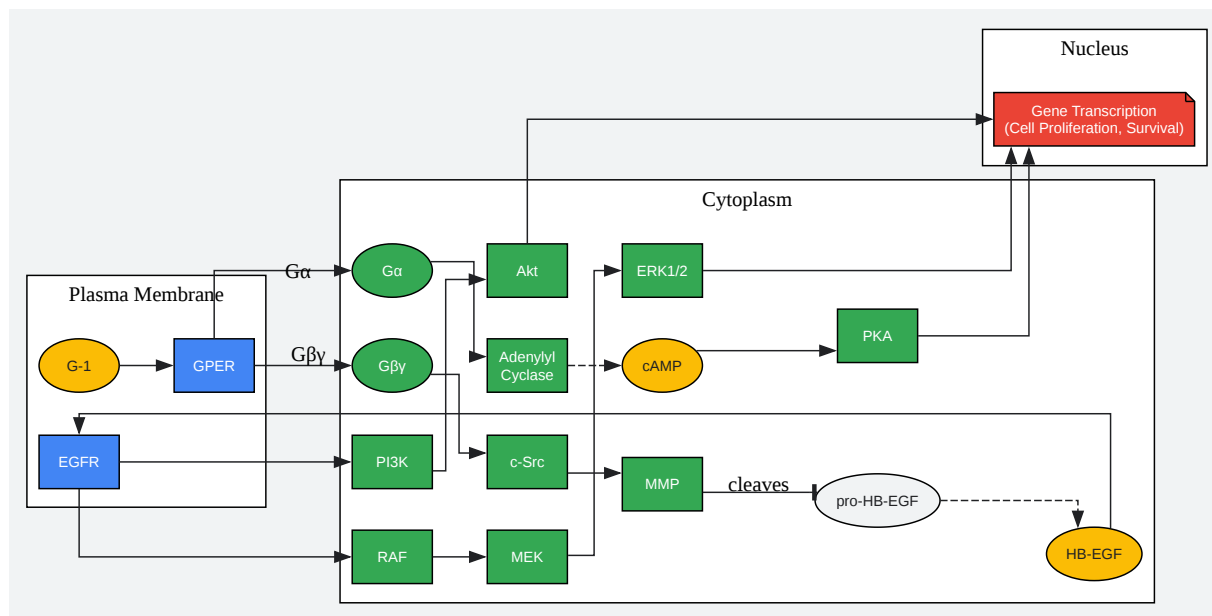

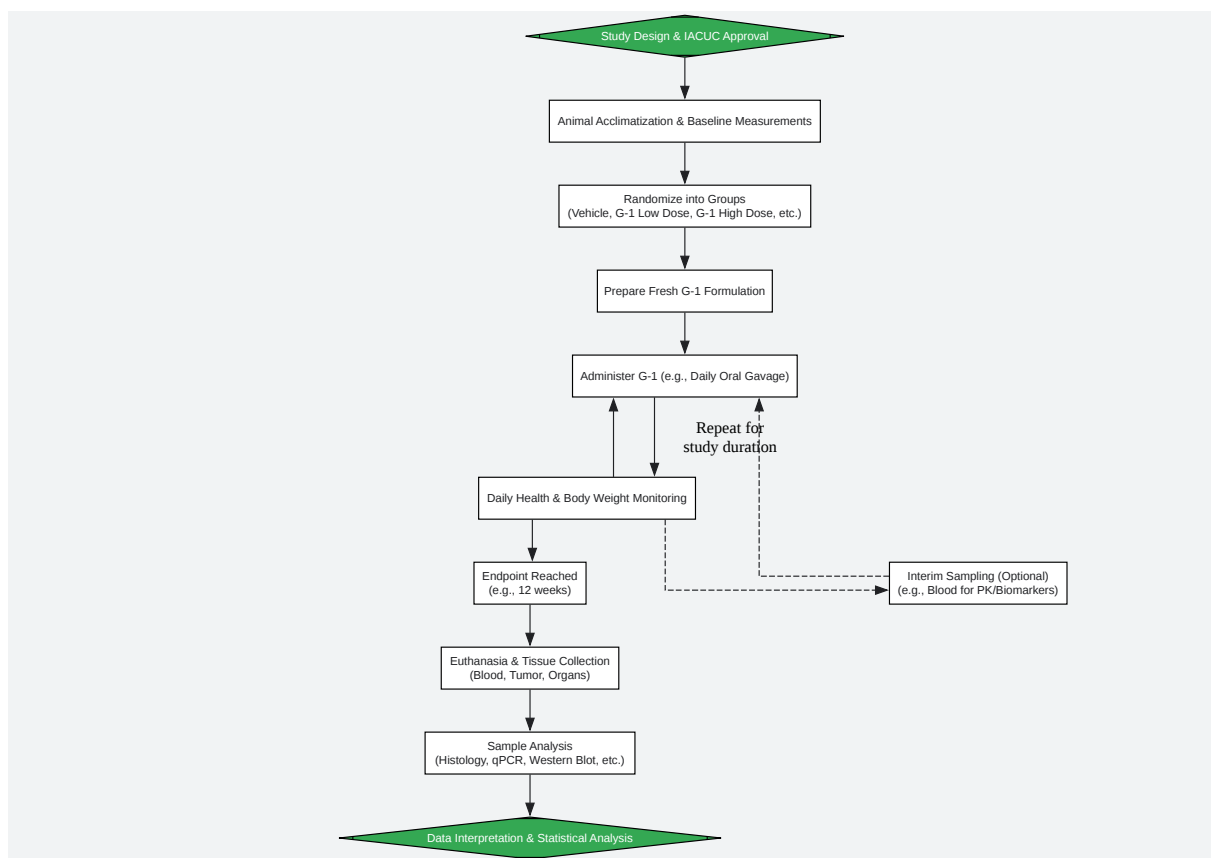

[Click to download full resolution via product page](#)

**Need Custom Synthesis?**

*BenchChem offers custom synthesis for rare earth carbides and specific isotopic labeling.*

*Email: [info@benchchem.com](mailto:info@benchchem.com) or [Request Quote Online](#).*

## References

- [1. What have we learned about GPER function in physiology and disease from knockout mice? - PMC \[pmc.ncbi.nlm.nih.gov\]](#)
- [2. Frontiers | G Protein-Coupled Estrogen Receptor, GPER1, Offers a Novel Target for the Treatment of Digestive Diseases \[frontiersin.org\]](#)
- [3. Reactome | GPER1 signaling \[reactome.org\]](#)
- [4. The Role of G Protein-Coupled Estrogen Receptor \(GPER\) in Vascular Pathology and Physiology - PMC \[pmc.ncbi.nlm.nih.gov\]](#)
- [5. researchgate.net \[researchgate.net\]](#)
- [6. researchgate.net \[researchgate.net\]](#)
- [7. The G-Protein–Coupled Estrogen Receptor Agonist G-1 Inhibits Proliferation and Causes Apoptosis in Leukemia Cell Lines of T Lineage - PMC \[pmc.ncbi.nlm.nih.gov\]](#)
- [8. benchchem.com \[benchchem.com\]](#)
- To cite this document: BenchChem. [challenges in using G-1 for long-term in vivo studies]. BenchChem, [2026]. [Online PDF]. Available at: [\[https://www.benchchem.com/product/b15606099/docs#challenges-in-using-g-1-for-long-term-in-vivo-studies\]](https://www.benchchem.com/product/b15606099/docs#challenges-in-using-g-1-for-long-term-in-vivo-studies)

---

### Disclaimer & Data Validity:

The information provided in this document is for Research Use Only (RUO) and is strictly not intended for diagnostic or therapeutic procedures. While BenchChem strives to provide accurate protocols, we make no warranties, express or implied, regarding the fitness of this product for every specific experimental setup.

**Technical Support:** The protocols provided are for reference purposes. Unsure if this reagent suits your experiment?

**Need Industrial/Bulk Grade?** [Request Custom Synthesis Quote](#)

# BenchChem

Our mission is to be the trusted global source of essential and advanced chemicals, empowering scientists and researchers to drive progress in science and industry.

## Contact

Address: 3281 E Guasti Rd

Ontario, CA 91761, United States

Phone: (601) 213-4426

Email: [info@benchchem.com](mailto:info@benchchem.com)

[Contact our Ph.D. Support Team for a compatibility check](#)