

ZM-32 Target Validation via CRISPR Knockout: A Comparative Guide

Author: BenchChem Technical Support Team. **Date:** April 2026

Compound of Interest

Compound Name: ZM-32
Cat. No.: B15606466

Get Quote

For Researchers, Scientists, and Drug Development Professionals

This guide provides a comprehensive comparison of the HuR inhibitor **ZM-32** with alternative compounds, supported by experimental data and detailed protocols for target validation using CRISPR-Cas9 technology.

Introduction to ZM-32 and Target Validation

ZM-32 is a small molecule inhibitor of the Human antigen R (HuR), an RNA-binding protein that plays a critical role in post-transcriptional gene regulation.[1] HuR stabilizes target messenger RNAs (mRNAs) containing AU-rich elements (AREs) in their 3'-untranslated regions, leading to increased protein expression of key oncogenes and inflammatory factors.[1] **ZM-32** competitively binds to the RRM1/2 structural domain of HuR, preventing the formation of the HuR-mRNA complex. This inhibitory action downregulates the expression of proteins such as VEGF-A and MMP9, which are crucial for tumor angiogenesis.[2]

The validation of a drug's intended target is a critical step in the drug discovery process to ensure its efficacy and minimize off-target effects. CRISPR-Cas9 gene editing has emerged as a powerful tool for definitive target validation.[3][4] By specifically knocking out the gene encoding the putative target protein, researchers can assess whether the cellular phenotype

observed with the small molecule inhibitor is recapitulated. If the knockout cells become resistant to the inhibitor, it provides strong evidence that the drug acts on-target.

HuR Signaling Pathway and Inhibitor Intervention Points

The accompanying diagram illustrates the signaling pathway influenced by HuR and highlights the points of intervention for **ZM-32** and other inhibitors. Under cellular stress, HuR translocates from the nucleus to the cytoplasm, where it binds to the AREs of target mRNAs, protecting them from degradation and promoting their translation. This leads to the upregulation of proteins involved in cell proliferation, angiogenesis, and inflammation. Inhibitors like **ZM-32** directly interfere with the HuR-mRNA interaction, while others may disrupt HuR dimerization or its nucleocytoplasmic shuttling.

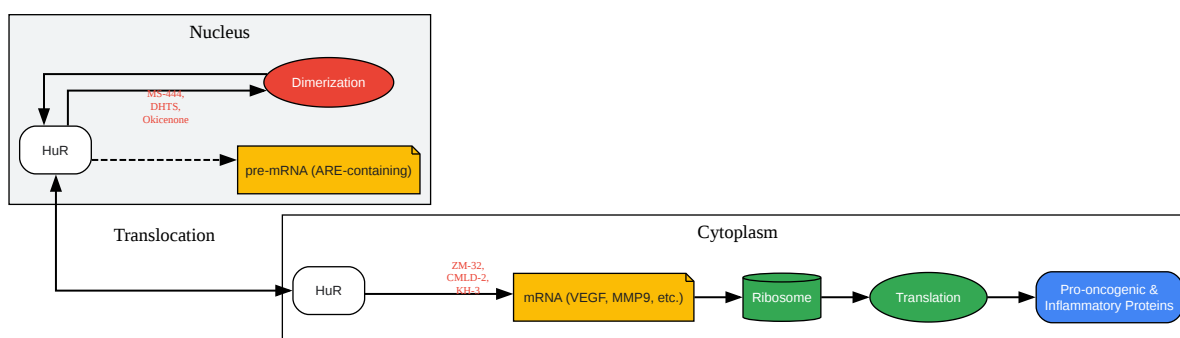

[Click to download full resolution via product page](#)

Caption: HuR signaling pathway and inhibitor intervention points.

Comparison of ZM-32 with Alternative HuR Inhibitors

Several small molecules have been developed to inhibit the function of HuR. The following table summarizes the available quantitative data for **ZM-32** and a selection of alternative inhibitors. It is important to note that the reported values may have been obtained from different experimental setups, which can influence direct comparability.

Inhibitor	Target Interaction	Ki (nM)	IC50 (μM)	Reference
ZM-32	HuR-mRNA interaction	521.7	-	[2]
MS-444	HuR dimerization/translocation	-	-	[5]
DHTS	HuR-mRNA interaction	3.74	-	[6]
Okicenone	HuR dimerization/translocation	-	-	[5]
CMLD-2	HuR-mRNA interaction	350	-	[1][7]
KH-3	HuR-mRNA interaction	-	0.35	[1][7]

Experimental Protocol: CRISPR-Cas9 Knockout of HuR for ZM-32 Validation

This protocol outlines the key steps for generating an HuR knockout cell line to validate the on-target activity of **ZM-32**.

I. Design and Cloning of sgRNA

- **sgRNA Design:** Design at least two single guide RNAs (sgRNAs) targeting an early exon of the ELAVL1 gene (encoding HuR) using a CRISPR design tool. Select sgRNAs with high on-target scores and low off-target predictions.
- **Vector Selection:** Choose a suitable lentiviral vector co-expressing Cas9 nuclease and the sgRNA cassette (e.g., lentiCRISPRv2).
- **Cloning:** Synthesize and anneal complementary oligonucleotides for the selected sgRNAs and clone them into the linearized CRISPR vector according to the manufacturer's protocol.
- **Verification:** Confirm successful cloning by Sanger sequencing.

II. Lentivirus Production and Transduction

- **Lentivirus Production:** Co-transfect HEK293T cells with the cloned sgRNA-Cas9 plasmid and lentiviral packaging plasmids (e.g., psPAX2 and pMD2.G).
- **Virus Harvest:** Collect the virus-containing supernatant at 48 and 72 hours post-transfection.
- **Transduction:** Transduce the target cancer cell line (e.g., MDA-MB-231) with the lentiviral particles in the presence of polybrene.

III. Selection and Validation of Knockout Cells

- **Antibiotic Selection:** Select transduced cells using the appropriate antibiotic (e.g., puromycin for lentiCRISPRv2).
- **Single-Cell Cloning:** Isolate single cells by limiting dilution or fluorescence-activated cell sorting (FACS) into 96-well plates to establish clonal populations.
- **Genomic DNA Analysis:**
 - Expand individual clones and extract genomic DNA.
 - Amplify the target region of the ELAVL1 gene by PCR.
 - Analyze the PCR products for insertions or deletions (indels) using methods like the T7 Endonuclease I (T7E1) assay or by Sanger sequencing followed by decomposition

analysis (e.g., TIDE).

- Protein Level Validation: Confirm the absence of HuR protein expression in the knockout clones by Western blot analysis.

IV. Phenotypic Assays for ZM-32 Validation

- Cell Viability/Proliferation Assay:
 - Plate wild-type (WT) and HuR knockout (KO) cells in 96-well plates.
 - Treat the cells with a dose range of **ZM-32** and a relevant alternative inhibitor.
 - After 72 hours, assess cell viability using an MTT or similar assay.
 - Expected Outcome: WT cells should show a dose-dependent decrease in viability upon treatment with **ZM-32**, while HuR KO cells should exhibit significant resistance to the compound.
- Angiogenesis Assay (Tube Formation Assay):
 - Culture human umbilical vein endothelial cells (HUVECs) in conditioned media from WT and HuR KO cancer cells treated with **ZM-32** or a vehicle control.
 - Plate HUVECs on Matrigel and incubate for 6-12 hours.
 - Quantify the formation of tube-like structures.
 - Expected Outcome: Conditioned media from **ZM-32**-treated WT cells should inhibit tube formation. This effect should be less pronounced with conditioned media from **ZM-32**-treated HuR KO cells.

Experimental Workflow Diagram

The following diagram outlines the workflow for validating **ZM-32**'s target using CRISPR-Cas9.

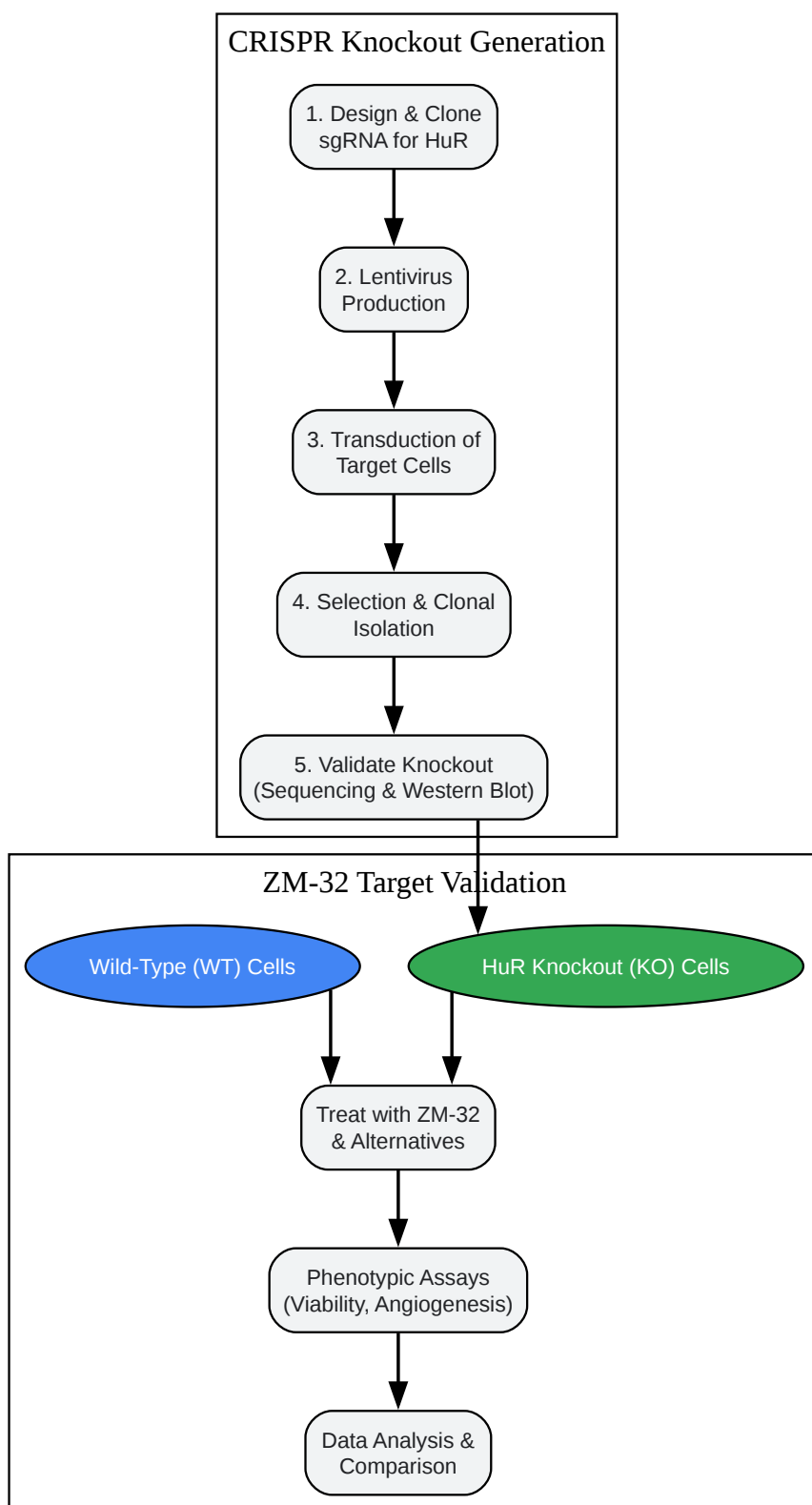

[Click to download full resolution via product page](#)

Caption: Workflow for **ZM-32** target validation with CRISPR knockout.

Conclusion

This guide provides a framework for the validation of **ZM-32** as a specific inhibitor of HuR. By employing CRISPR-Cas9 to generate a clean genetic knockout of the ELAVL1 gene, researchers can unequivocally demonstrate the on-target effects of **ZM-32**. The comparison with alternative inhibitors, coupled with robust phenotypic assays, will further solidify the understanding of **ZM-32**'s mechanism of action and its therapeutic potential. The detailed protocols and structured data presentation are intended to facilitate the replication and extension of these validation studies.

Need Custom Synthesis?

BenchChem offers custom synthesis for rare earth carbides and specific isotopic labeling.

Email: info@benchchem.com or [Request Quote Online](#).

References

- [1. medchemexpress.com](https://www.medchemexpress.com) [[medchemexpress.com](https://www.medchemexpress.com)]
- [2. horizondiscovery.com](https://www.horizondiscovery.com) [[horizondiscovery.com](https://www.horizondiscovery.com)]
- [3. A high-throughput platform to identify small-molecule inhibitors of CRISPR-Cas9 - PMC](#) [[pmc.ncbi.nlm.nih.gov](https://pubmed.ncbi.nlm.nih.gov/31111111/)]
- [4. RNA-binding protein HuR is an emerging target for cancer therapeutics and immune-related disorders - PMC](#) [[pmc.ncbi.nlm.nih.gov](https://pubmed.ncbi.nlm.nih.gov/31111111/)]
- [5. aacrjournals.org](https://www.aacrjournals.org) [[aacrjournals.org](https://www.aacrjournals.org)]
- [6. researchgate.net](https://www.researchgate.net) [[researchgate.net](https://www.researchgate.net)]
- [7. HuR \(Inhibitors Agonists Modulators Antagonists\) | TargetMol](#) [[targetmol.com](https://www.targetmol.com)]
- To cite this document: BenchChem. [ZM-32 Target Validation via CRISPR Knockout: A Comparative Guide]. BenchChem, [2026]. [Online PDF]. Available at: [<https://www.benchchem.com/product/b15606466/docs#zm-32-target-validation-via-crispr-knockout-a-comparative-guide>]

Disclaimer & Data Validity:

The information provided in this document is for Research Use Only (RUO) and is strictly not intended for diagnostic or therapeutic procedures. While BenchChem strives to provide accurate protocols, we make no warranties, express or implied, regarding the fitness of this product for every specific experimental setup.

Technical Support: The protocols provided are for reference purposes. Unsure if this reagent suits your experiment?

Need Industrial/Bulk Grade? [Request Custom Synthesis Quote](#)

BenchChem

Our mission is to be the trusted global source of essential and advanced chemicals, empowering scientists and researchers to drive progress in science and industry.

Contact

Address: 3281 E Guasti Rd
Ontario, CA 91761, United States
Phone: (601) 213-4426
Email: info@benchchem.com

[Contact our Ph.D. Support Team for a compatibility check](#)