

The Biological Activity of RWJ 50271: A Technical Guide

Author: BenchChem Technical Support Team. **Date:** April 2026

Compound of Interest

Compound Name: RWJ 50271

Cat. No.: B15606425

[Get Quote](#)

For Researchers, Scientists, and Drug Development Professionals

Abstract

RWJ 50271 is a selective, small-molecule inhibitor of the protein-protein interaction between Lymphocyte Function-Associated Antigen-1 (LFA-1) and Intercellular Adhesion Molecule-1 (ICAM-1). This interaction is a critical component of the immune response, mediating the adhesion and trafficking of leukocytes. By disrupting this interaction, **RWJ 50271** demonstrates potential as a modulator of inflammatory and immune responses. This document provides a comprehensive overview of the biological activity of **RWJ 50271**, including its quantitative inhibitory effects, a detailed representative experimental protocol for assessing its activity, and visualizations of the relevant biological pathway and experimental workflow.

Introduction

The adhesion of leukocytes to the endothelium and their subsequent migration into tissues is a fundamental process in the inflammatory cascade and immune surveillance. This process is mediated by a family of cell adhesion molecules, among which the interaction between the integrin LFA-1 (CD11a/CD18), expressed on the surface of leukocytes, and its ligand ICAM-1 (CD54), expressed on endothelial cells and other cell types, plays a pivotal role. The LFA-

LFA-1/ICAM-1 axis is implicated in a variety of inflammatory and autoimmune diseases, making it an attractive target for therapeutic intervention. **RWJ 50271** has emerged as a specific inhibitor of this interaction, offering a tool for both research and potential drug development.

Quantitative Biological Activity

The primary biological activity of **RWJ 50271** is the inhibition of LFA-1/ICAM-1-mediated cell adhesion. The potency of this inhibition has been quantified in a cell-based assay.

Compound	Assay Type	Cell Line	Target	IC50 (μ M)	Reference
RWJ 50271	LFA-1/ICAM-1 Mediated Cell Adhesion	HL60	Integrin	5	[1][2]

Table 1: Inhibitory Potency of **RWJ 50271**. The half-maximal inhibitory concentration (IC50) of **RWJ 50271** was determined in a cell adhesion assay using the human promyelocytic leukemia cell line, HL60.

Signaling Pathway and Mechanism of Action

RWJ 50271 acts by directly interfering with the binding of LFA-1 on leukocytes to ICAM-1 on target cells, such as endothelial cells. This inhibition prevents the firm adhesion of leukocytes, a critical step for their transmigration from the bloodstream into tissues.

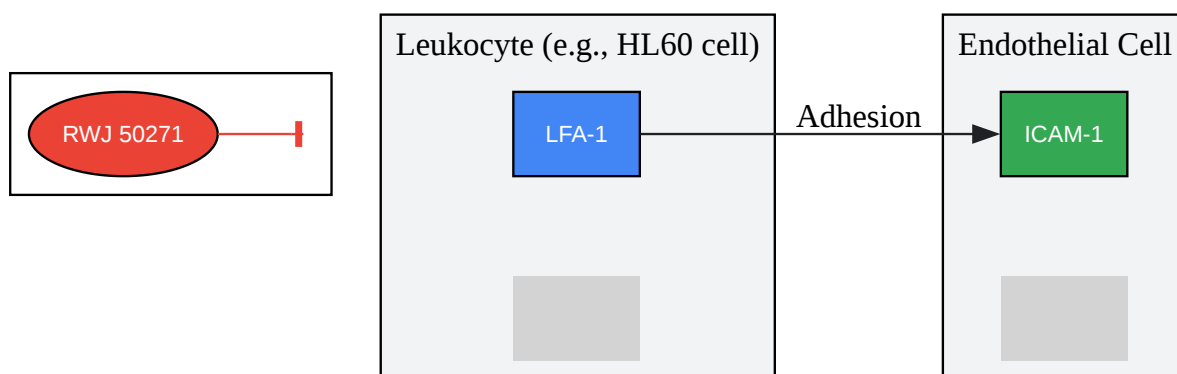

[Click to download full resolution via product page](#)

Figure 1: LFA-1/ICAM-1 Signaling Pathway Inhibition. This diagram illustrates the interaction between LFA-1 on a leukocyte and ICAM-1 on an endothelial cell, leading to cell adhesion.

RWJ 50271 is shown to inhibit this interaction.

Experimental Protocols

The following is a representative protocol for an in vitro LFA-1/ICAM-1-mediated cell adhesion assay, based on standard methodologies used to evaluate inhibitors like **RWJ 50271**.

Objective

To determine the concentration-dependent inhibition of LFA-1/ICAM-1-mediated adhesion of HL60 cells by **RWJ 50271**.

Materials

- Human promyelocytic leukemia cell line (HL60)
- Recombinant human ICAM-1/Fc chimera
- 96-well microtiter plates (high-binding)
- Bovine Serum Albumin (BSA)
- Phosphate Buffered Saline (PBS)
- Assay buffer (e.g., RPMI 1640)
- Calcein-AM (or other fluorescent cell stain)
- **RWJ 50271**
- Fluorescence plate reader

Methodology

- Plate Coating:

- Coat the wells of a 96-well microtiter plate with recombinant human ICAM-1/Fc by incubating overnight at 4°C. A typical concentration is 1-5 µg/mL in PBS.
- Wash the wells three times with PBS to remove unbound ICAM-1.
- Block non-specific binding sites by incubating the wells with a solution of 1% BSA in PBS for 1-2 hours at room temperature.
- Wash the wells three times with PBS.
- Cell Preparation:
 - Culture HL60 cells in appropriate media until they reach the desired density.
 - Label the HL60 cells with a fluorescent dye, such as Calcein-AM, according to the manufacturer's instructions. This allows for the quantification of adherent cells.
 - Wash the labeled cells to remove excess dye and resuspend them in assay buffer at a concentration of 1-2 x 10⁶ cells/mL.
- Inhibition Assay:
 - Prepare serial dilutions of **RWJ 50271** in the assay buffer.
 - Add the various concentrations of **RWJ 50271** to the ICAM-1 coated and blocked wells.
 - Add the fluorescently labeled HL60 cell suspension to the wells.
 - Incubate the plate for 30-60 minutes at 37°C in a humidified incubator to allow for cell adhesion.
- Quantification of Adhesion:
 - After incubation, gently wash the wells to remove non-adherent cells. This can be done by inverting the plate and gently immersing it in a beaker of PBS.
 - After washing, add a lysis buffer to each well to release the fluorescent dye from the adherent cells.

- Measure the fluorescence in each well using a fluorescence plate reader at the appropriate excitation and emission wavelengths for the chosen dye.
- Data Analysis:
 - The fluorescence intensity is directly proportional to the number of adherent cells.
 - Calculate the percentage of inhibition for each concentration of **RWJ 50271** relative to the control (wells with no inhibitor).
 - Plot the percentage of inhibition against the logarithm of the inhibitor concentration and fit the data to a sigmoidal dose-response curve to determine the IC₅₀ value.

Experimental Workflow

The following diagram outlines the key steps in the LFA-1/ICAM-1 cell adhesion inhibition assay.

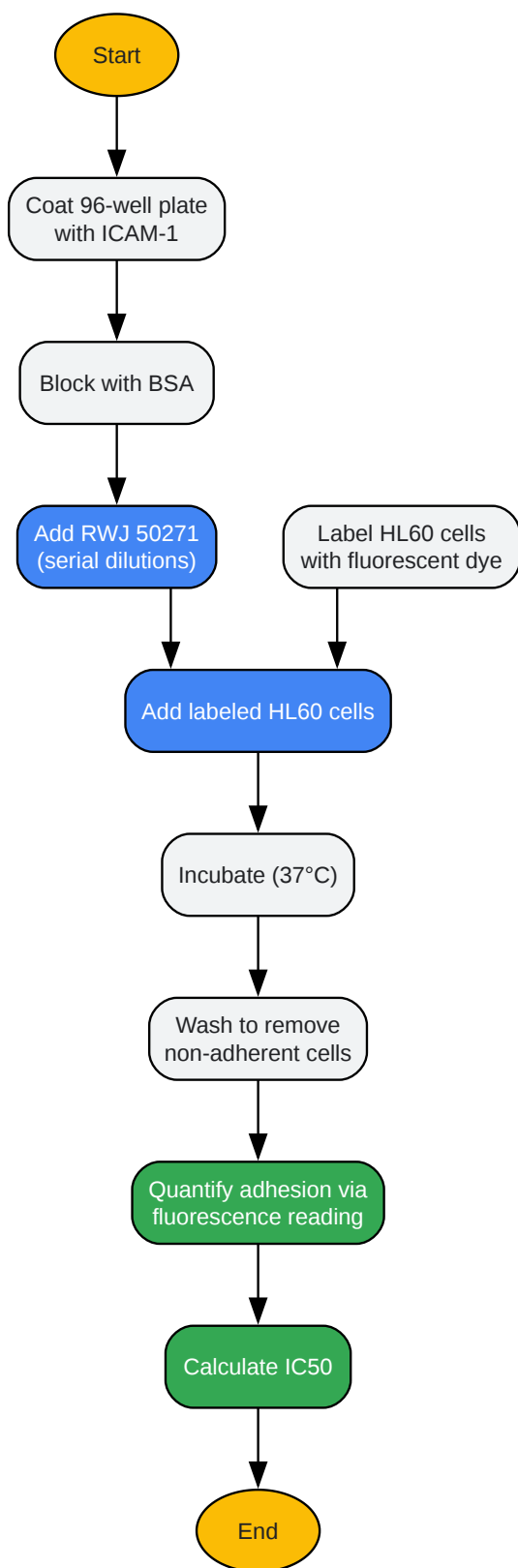

[Click to download full resolution via product page](#)

Figure 2: LFA-1/ICAM-1 Adhesion Assay Workflow. This flowchart illustrates the sequential steps involved in determining the inhibitory activity of **RWJ 50271** on cell adhesion.

Conclusion

RWJ 50271 is a valuable research tool for studying the roles of LFA-1/ICAM-1-mediated cell adhesion in various physiological and pathological processes. Its selective inhibitory activity provides a means to dissect the molecular mechanisms of leukocyte trafficking and activation. The data and protocols presented in this guide offer a foundational understanding of the biological activity of **RWJ 50271** and a framework for its further investigation and potential application in drug discovery programs targeting inflammatory and autoimmune disorders.

Need Custom Synthesis?

BenchChem offers custom synthesis for rare earth carbides and specific isotopic labeling.

Email: info@benchchem.com or [Request Quote Online](#).

References

- [1. Intercellular Adhesion Molecule 1 \(ICAM-1\): Getting a Grip on Leukocyte Adhesion - PMC \[pmc.ncbi.nlm.nih.gov\]](#)
- [2. Static Adhesion Assay for the Study of Integrin Activation in T Lymphocytes - PMC \[pmc.ncbi.nlm.nih.gov\]](#)
- To cite this document: BenchChem. [The Biological Activity of RWJ 50271: A Technical Guide]. BenchChem, [2026]. [Online PDF]. Available at: [\[https://www.benchchem.com/product/b15606425/docs#the-biological-activity-of-rwj-50271-a-technical-guide\]](https://www.benchchem.com/product/b15606425/docs#the-biological-activity-of-rwj-50271-a-technical-guide)

Disclaimer & Data Validity:

The information provided in this document is for Research Use Only (RUO) and is strictly not intended for diagnostic or therapeutic procedures. While BenchChem strives to provide accurate protocols, we make no warranties, express or implied, regarding the fitness of this product for every specific experimental setup.

Technical Support: The protocols provided are for reference purposes. Unsure if this reagent suits your experiment?

Need Industrial/Bulk Grade? [Request Custom Synthesis Quote](#)

BenchChem

Our mission is to be the trusted global source of essential and advanced chemicals, empowering scientists and researchers to drive progress in science and industry.

Contact

Address: 3281 E Guasti Rd
Ontario, CA 91761, United States
Phone: (601) 213-4426
Email: info@benchchem.com

[Contact our Ph.D. Support Team for a compatibility check](#)