

# Technical Support Center: Interpreting Variable Results in BACE2 Inhibition Experiments

**Author:** BenchChem Technical Support Team. **Date:** April 2026

## Compound of Interest

Compound Name: *Bace2-IN-1*

Cat. No.: *B15606792*

[Get Quote](#)

This technical support center provides troubleshooting guides and FAQs to help researchers, scientists, and drug development professionals interpret and resolve variable results in BACE2 inhibition experiments.

## Frequently Asked Questions (FAQs)

Q1: What are the primary reasons for inconsistent IC50 values in my BACE2 enzymatic assays?

A1: Inconsistent IC50 values in BACE2 enzymatic assays can stem from several factors:

- **Enzyme Quality and Handling:** The purity, concentration, and handling of recombinant BACE2 are critical. Inconsistent enzyme activity can result from improper storage, multiple freeze-thaw cycles, or batch-to-batch variation.
- **Substrate and Buffer Conditions:** The stability of the substrate and the composition of the assay buffer, including pH and ionic strength, can significantly influence enzyme activity. Assays are typically performed at an acidic pH (around 4.0-4.5) to mimic the environment of endosomes where BACE2 is active.<sup>[1]</sup>

- **Assay-Specific Parameters:** Variations in incubation times, temperature, and the presence of detergents can all affect the final IC<sub>50</sub> value.
- **Inhibitor Solubility and Stability:** Poor solubility of the test compound in the assay buffer can lead to an overestimation of the IC<sub>50</sub>. The stability of the compound under assay conditions should also be considered.

Q2: My inhibitor shows high potency in an enzymatic assay but weak activity in a cell-based assay. What could be the cause?

A2: This discrepancy is common and can be attributed to several factors:

- **Cell Permeability:** The inhibitor may have poor membrane permeability, preventing it from reaching its intracellular target.[2]
- **Efflux Pumps:** The compound may be a substrate for cellular efflux pumps, which actively transport it out of the cell.
- **Cellular Metabolism:** The inhibitor could be metabolized by the cells into an inactive form.
- **Off-Target Binding:** The compound might bind to other cellular components, reducing its effective concentration at the target.
- **Assay Conditions:** The intracellular environment (e.g., pH, presence of other proteins) can differ significantly from the conditions of an enzymatic assay.

Q3: How can I determine if my BACE2 inhibitor is also inhibiting BACE1 or other proteases?

A3: Due to the high homology between the active sites of BACE1 and BACE2, achieving selectivity is a significant challenge.[3] To assess selectivity, you should:

- **Perform Counter-Screening Assays:** Test your inhibitor against recombinant BACE1 and other relevant proteases, such as Cathepsin D, under similar assay conditions.[2][4]
- **Analyze Cellular Products:** In a cell-based assay, measure the levels of specific cleavage products of BACE1 and BACE2 substrates. For example, BACE1 is the primary producer of A $\beta$  from APP, while BACE2 can cleave APP at a different site.[3][5]

- Utilize BACE1/BACE2 Knockout/Knockdown Cells: Employing cells where BACE1 or BACE2 expression is silenced can help to dissect the specific effects of your inhibitor.

Q4: What are common sources of variability in cell-based BACE2 assays?

A4: Variability in cell-based assays can arise from:

- Cell Line and Passage Number: Different cell lines have varying endogenous levels of BACE2 and its substrates.[6] High passage numbers can lead to genetic drift and altered cellular phenotypes.
- Transfection Efficiency: If you are overexpressing BACE2 or its substrate, variations in transfection efficiency will lead to inconsistent results.
- Cell Health and Density: The health and confluency of your cells at the time of the experiment can impact their response to the inhibitor.
- Incubator Conditions: Fluctuations in temperature, CO<sub>2</sub>, and humidity can introduce variability.[7]

## Troubleshooting Guides

### Issue 1: High Background Signal or False Positives in FRET-Based Enzymatic Assay

Potential Cause	Troubleshooting Step
Autofluorescence of Test Compound	Pre-read the plate after adding the compound but before adding the enzyme to quantify its intrinsic fluorescence. Subtract this background from the final reading.
Compound Interferes with Detection	Test the compound's effect on the fluorescence of the cleaved substrate standard to check for quenching or enhancement effects.[8]
Contaminated Reagents	Use fresh, high-purity reagents and sterile, nuclease-free water to prepare buffers and solutions.
Non-Specific Protease Activity	Include a control with a broad-spectrum protease inhibitor cocktail to assess the contribution of non-BACE2 proteases.

## Issue 2: Inconsistent BACE2 Expression in Western Blots

Potential Cause	Troubleshooting Step
Inefficient Protein Extraction	Use a lysis buffer optimized for membrane proteins, containing appropriate detergents (e.g., RIPA buffer). Ensure complete cell lysis through sonication or mechanical disruption.
Poor Antibody Performance	Validate the primary antibody using a positive control (e.g., recombinant BACE2 or lysate from BACE2-overexpressing cells) and a negative control (e.g., lysate from BACE2-knockout cells). Test different antibody dilutions.
Protein Degradation	Add a protease inhibitor cocktail to the lysis buffer and keep samples on ice throughout the procedure.
Uneven Protein Loading	Perform a total protein quantification assay (e.g., BCA) on your lysates and load equal amounts of protein per lane. Use a reliable loading control like $\beta$ -actin or GAPDH for normalization. <a href="#">[9]</a>

## Quantitative Data Summary

Table 1: Potency and Selectivity of Representative BACE Inhibitors

Compound	BACE1 IC50 (nM)	BACE2 IC50 (nM)	Selectivity (BACE2/BACE 1)	Reference
Verubecestat (MK-8931)	13	25	1.9	[10]
Elenbecestat (E2609)	3.9	46	11.8	[11][12]
Shionogi Compound 1	3.9	148	37.9	[11]
Shionogi Compound 2	7.7	307	39.9	[11]
AMG-8718	0.7	5	7.1	[13]
BACE1/2-IN-1	10	5.3	0.53	[13]

Table 2: BACE2 Expression in Various Cell Lines and Tissues

Cell Line/Tissue	BACE2 Expression Level	Reference
HEK293	Low endogenous expression	[6][14]
SH-SY5Y	Low endogenous expression	[15]
Astrocytes	Expressed	[14][16]
Neurons	Lower than astrocytes	[14]
Pancreatic $\beta$ -cells	Expressed	[16]
Heart, Kidney, Placenta	High expression	[17]

## Experimental Protocols

### Protocol 1: In Vitro BACE2 Inhibition Assay (FRET-Based)

Objective: To determine the in vitro potency (IC50) of a test compound against BACE2.

Materials:

- Recombinant human BACE2 enzyme
- Fluorogenic BACE2 substrate peptide (e.g., based on the Swedish mutation of APP)
- Assay Buffer: 50 mM Sodium Acetate, pH 4.5
- Test compound and a known BACE2 inhibitor (positive control)
- DMSO
- Black, flat-bottom 96-well microplate
- Fluorescence plate reader

Procedure:

- Compound Preparation: Prepare a serial dilution of the test compound in DMSO. Further dilute in Assay Buffer to the final desired concentrations. The final DMSO concentration should be consistent across all wells and typically below 1%.
- Assay Plate Setup:
  - Add Assay Buffer to all wells.
  - Add the diluted test compound or control solutions to the appropriate wells.
  - Include wells for a vehicle control (DMSO) and a no-enzyme control.
- Enzyme Addition: Add the BACE2 enzyme to all wells except the no-enzyme control.
- Pre-incubation: Pre-incubate the plate at 37°C for 15 minutes.
- Reaction Initiation: Add the fluorogenic BACE2 substrate to all wells to start the reaction.

- **Fluorescence Reading:** Immediately begin kinetic reading of the fluorescence signal at the appropriate excitation and emission wavelengths for the chosen substrate. Read every 5 minutes for 60 minutes at 37°C.
- **Data Analysis:**
  - Calculate the initial reaction velocity ( $v$ ) for each well.
  - Normalize the data to the vehicle control (100% activity) and the no-enzyme control (0% activity).
  - Plot the percent inhibition versus the logarithm of the inhibitor concentration and fit the data to a four-parameter logistic equation to determine the IC<sub>50</sub> value.

## Protocol 2: Cell-Based BACE2 Inhibition Assay

**Objective:** To assess the ability of a compound to inhibit BACE2 activity in a cellular context.

**Materials:**

- HEK293 cells stably expressing human APP (or another suitable cell line)
- Cell culture medium (e.g., DMEM with 10% FBS)
- Test compound and a known BACE2 inhibitor
- DMSO
- 96-well cell culture plates
- ELISA kit for detecting a BACE2-specific cleavage product (e.g., sAPP $\beta$  or A $\beta$ )

**Procedure:**

- **Cell Seeding:** Seed HEK293-APP cells into a 96-well plate at an appropriate density and incubate for 24 hours.
- **Compound Treatment:** Prepare dilutions of the test compound in cell culture medium. Remove the old medium from the cells and add the medium containing the test compound or

controls.

- Incubation: Incubate the cells for a predetermined time (e.g., 24-48 hours) to allow for BACE2 inhibition and accumulation of the cleavage product.
- Sample Collection: Collect the conditioned medium from each well.
- ELISA: Measure the concentration of the BACE2 cleavage product in the conditioned medium using a specific ELISA kit according to the manufacturer's instructions.
- Cell Viability Assay (Optional): Perform a cell viability assay (e.g., MTT or LDH) on the cells to assess any cytotoxic effects of the treatment.
- Data Analysis:
  - Normalize the cleavage product concentrations to cell viability or total protein content.
  - Calculate the percent inhibition relative to the vehicle control.
  - Determine the IC50 value by plotting percent inhibition against the log of the compound concentration.

## Protocol 3: Western Blot for BACE2 Expression

Objective: To detect and quantify the expression of BACE2 protein in cell lysates.

Materials:

- Cell pellets
- RIPA lysis buffer with protease inhibitors
- BCA protein assay kit
- SDS-PAGE gels and running buffer
- PVDF membrane
- Transfer buffer

- Blocking buffer (e.g., 5% non-fat milk or BSA in TBST)
- Primary antibody against BACE2
- Loading control primary antibody (e.g.,  $\beta$ -actin, GAPDH)
- HRP-conjugated secondary antibody
- ECL substrate
- Chemiluminescence imaging system

#### Procedure:

- Protein Extraction: Lyse cell pellets in RIPA buffer on ice. Centrifuge to pellet cell debris and collect the supernatant containing the protein lysate.
- Protein Quantification: Determine the total protein concentration of each lysate using a BCA assay.
- SDS-PAGE: Load equal amounts of protein (e.g., 20-30  $\mu$ g) per lane onto an SDS-PAGE gel. Include a molecular weight marker.
- Electrophoretic Transfer: Transfer the separated proteins from the gel to a PVDF membrane.
- Blocking: Block the membrane for 1 hour at room temperature in blocking buffer.
- Primary Antibody Incubation: Incubate the membrane with the primary anti-BACE2 antibody and the loading control antibody overnight at 4°C.
- Washing: Wash the membrane three times with TBST.
- Secondary Antibody Incubation: Incubate with the appropriate HRP-conjugated secondary antibody for 1 hour at room temperature.
- Detection: Add ECL substrate and image the blot using a chemiluminescence imager.

- Data Analysis: Quantify the band intensities using image analysis software. Normalize the BACE2 band intensity to the loading control band intensity.

## Visualizations

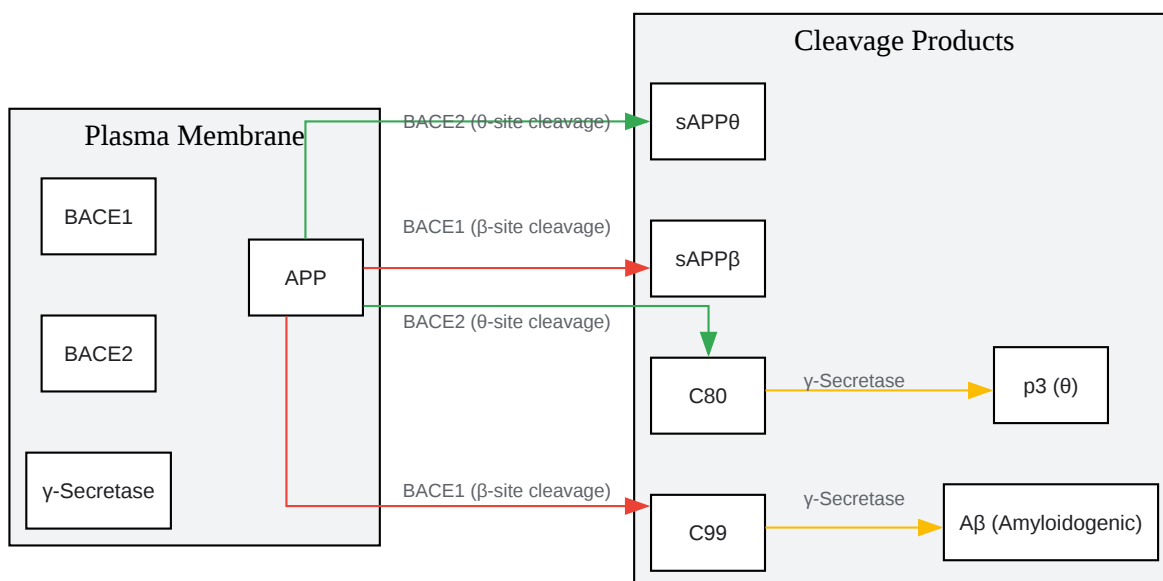

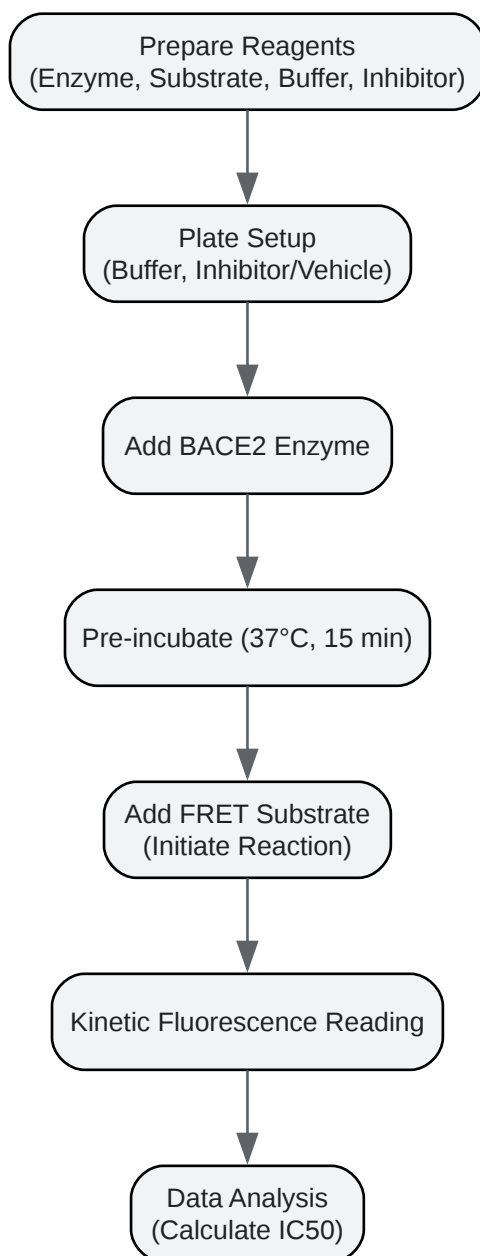

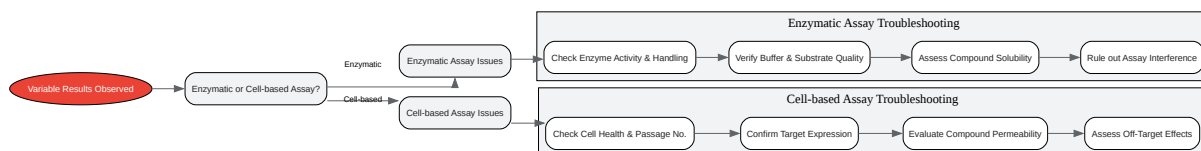
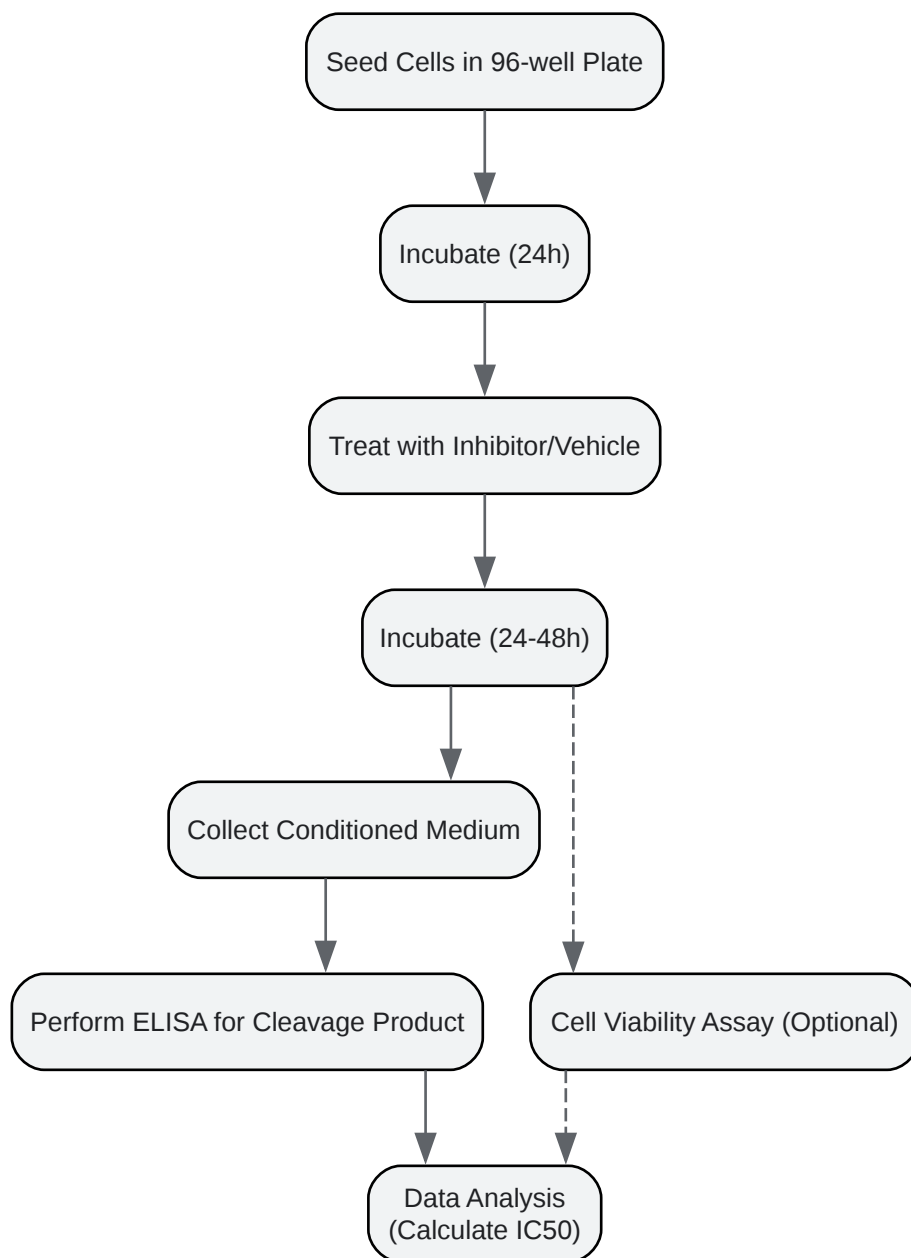

[Click to download full resolution via product page](#)

### Need Custom Synthesis?

*BenchChem offers custom synthesis for rare earth carbides and specific isotopic labeling.*

*Email: [info@benchchem.com](mailto:info@benchchem.com) or [Request Quote Online](#).*

## References

- [1. benchchem.com \[benchchem.com\]](#)
- [2. A Structure-Based Discovery Platform for BACE2 and the Development of Selective BACE Inhibitors - PMC \[pmc.ncbi.nlm.nih.gov\]](#)
- [3. researchgate.net \[researchgate.net\]](#)
- [4. Lessons from a BACE inhibitor trial: Off-site but not off base - PMC \[pmc.ncbi.nlm.nih.gov\]](#)
- [5. BACE1 and BACE2 Enzymatic Activities in Alzheimer's Disease - PMC \[pmc.ncbi.nlm.nih.gov\]](#)
- [6. researchgate.net \[researchgate.net\]](#)
- [7. Adapting Cell-Based Assays to the High Throughput Screening Platform: Problems Encountered and Lessons Learned - PMC \[pmc.ncbi.nlm.nih.gov\]](#)
- [8. Protease Assays - Assay Guidance Manual - NCBI Bookshelf \[ncbi.nlm.nih.gov\]](#)
- [9. researchgate.net \[researchgate.net\]](#)
- [10. benchchem.com \[benchchem.com\]](#)
- [11. New Highly Selective BACE1 Inhibitors and Their Effects on Dendritic Spine Density In Vivo \[mdpi.com\]](#)
- [12. mdpi.com \[mdpi.com\]](#)
- [13. medchemexpress.com \[medchemexpress.com\]](#)
- [14. BACE2: A Promising Neuroprotective Candidate for Alzheimer's Disease - PMC \[pmc.ncbi.nlm.nih.gov\]](#)
- [15. BACE2 Polyclonal Antibody \(PA1-754\) \[thermofisher.com\]](#)
- [16. BACE2 distribution in major brain cell types and identification of novel substrates - PMC \[pmc.ncbi.nlm.nih.gov\]](#)

- 17. BACE2, a  $\beta$ -secretase homolog, cleaves at the  $\beta$  site and within the amyloid- $\beta$  region of the amyloid- $\beta$  precursor protein - PMC [pmc.ncbi.nlm.nih.gov]
- To cite this document: BenchChem. [Technical Support Center: Interpreting Variable Results in BACE2 Inhibition Experiments]. BenchChem, [2026]. [Online PDF]. Available at: [https://www.benchchem.com/product/b15606792/docs#technical-support-center-interpreting-variable-results-in-bace2-inhibition-experiments]

---

### Disclaimer & Data Validity:

The information provided in this document is for Research Use Only (RUO) and is strictly not intended for diagnostic or therapeutic procedures. While BenchChem strives to provide accurate protocols, we make no warranties, express or implied, regarding the fitness of this product for every specific experimental setup.

**Technical Support:** The protocols provided are for reference purposes. Unsure if this reagent suits your experiment?

**Need Industrial/Bulk Grade?** [Request Custom Synthesis Quote](#)

## BenchChem

Our mission is to be the trusted global source of essential and advanced chemicals, empowering scientists and researchers to drive progress in science and industry.

### Contact

Address: 3281 E Guasti Rd  
Ontario, CA 91761, United States  
Phone: (601) 213-4426  
Email: [info@benchchem.com](mailto:info@benchchem.com)

[Contact our Ph.D. Support Team for a compatibility check](#)