

Technical Support Center: Cell Line-Specific Responses to Anthramycin Treatment

Author: BenchChem Technical Support Team. **Date:** April 2026

Compound of Interest

Compound Name: Adxanthromycin A

Cat. No.: B15606372

[Get Quote](#)

Welcome to the technical support center for researchers, scientists, and drug development professionals working with anthramycin. This resource provides troubleshooting guides and frequently asked questions (FAQs) to address common issues encountered during in vitro experiments.

Frequently Asked questions (FAQs)

Q1: What is the mechanism of action of anthramycin?

Anthramycin is a pyrrolobenzodiazepine antibiotic that exhibits potent anti-tumor activity. Its primary mechanism of action involves binding to the minor groove of DNA, which inhibits both DNA and RNA synthesis, ultimately leading to cytotoxicity in cancer cells.^[1]

Q2: Why do I observe different levels of cytotoxicity with anthramycin across various cancer cell lines?

Cell line-specific responses to anthramycin are common and can be attributed to several factors, including:

- Differences in drug uptake and efflux: Variations in the expression of drug transporters can affect the intracellular concentration of anthramycin.
- DNA repair capacity: Cell lines with more efficient DNA repair mechanisms may better tolerate the DNA damage induced by anthramycin.
- Cellular proliferation rate: Rapidly dividing cells may be more susceptible to agents that interfere with DNA replication.
- Genetic and epigenetic differences: Variations in gene expression, such as the status of tumor suppressor genes (e.g., p53) and oncogenes, can influence drug sensitivity.

Q3: My IC50 values for anthramycin are inconsistent between experiments. What are the potential causes?

Inconsistent IC50 values can arise from several experimental variables:

- Cell density: The initial number of cells seeded can significantly impact the final assay readout. Ensure consistent cell seeding density across all experiments.
- Compound stability: Anthramycin may be sensitive to light and temperature. Prepare fresh dilutions for each experiment and minimize exposure to harsh conditions.
- Assay timing: The duration of drug exposure and the timing of the viability assay can affect the calculated IC50. Standardize these parameters in your protocol.
- Reagent variability: Ensure all reagents, including cell culture media and assay components, are from consistent lots and are not expired.
- Cell health and passage number: Use cells that are in the logarithmic growth phase and are within a consistent, low passage number range to minimize variability.^[2]

Data Presentation

The following table summarizes the cytotoxic effects of anthramycin analogs against the MCF-7 human breast cancer cell line.

Compound Code	IC50 ($\mu\text{g/mL}$)
RVB-01	1.3
RVB-04	1.22
RVB-05	1.14
RVB-09	1.31
Cisplatin	19.5

Data from in vitro MTT assay against MCF-7 cell line.[3][4]

Troubleshooting Guides

MTT Assay for Cell Viability

Issue: High background absorbance in control wells.

Potential Cause	Troubleshooting Steps
Contamination of media or reagents	Use fresh, sterile media and reagents. Filter sterilize solutions if necessary.
Phenol red interference	Use phenol red-free media for the assay.
High cell seeding density	Optimize cell number to ensure linearity of the assay.

Issue: Low signal or poor dose-response.

Potential Cause	Troubleshooting Steps
Insufficient incubation time	Increase the incubation time with both anthramycin and the MTT reagent to allow for a measurable effect.
Cell detachment	Be gentle during washing steps to avoid losing adherent cells.
Incomplete formazan solubilization	Ensure complete dissolution of formazan crystals by adding an adequate volume of solubilization buffer and mixing thoroughly.

Flow Cytometry for Apoptosis (Annexin V/PI Staining)

Issue: High percentage of necrotic (Annexin V+/PI+) cells in the untreated control.

Potential Cause	Troubleshooting Steps
Harsh cell handling	Handle cells gently during harvesting and staining to avoid mechanical damage to the cell membrane.
Over-trypsinization	Use the minimum necessary concentration and incubation time for trypsinization.
Unhealthy initial cell population	Ensure cells are in the logarithmic growth phase and have high viability before starting the experiment.

Issue: No significant increase in apoptotic cells after anthramycin treatment.

Potential Cause	Troubleshooting Steps
Incorrect assay timing	Apoptosis is a dynamic process. Perform a time-course experiment (e.g., 24, 48, 72 hours) to determine the optimal endpoint for detecting apoptosis in your cell line.[5]
Suboptimal drug concentration	The concentration of anthramycin may be too low to induce a detectable apoptotic response. Perform a dose-response experiment.
Loss of apoptotic cells	Apoptotic cells can detach from the culture plate. Collect both the supernatant and adherent cells for analysis.[3]

Western Blot for Signaling Pathway Analysis

Issue: High background on the western blot membrane.

Potential Cause	Troubleshooting Steps
Inadequate blocking	Increase the blocking time or try a different blocking agent (e.g., 5% BSA instead of milk for phospho-antibodies).
Antibody concentration too high	Titrate the primary and secondary antibody concentrations to find the optimal dilution.
Insufficient washing	Increase the number and duration of wash steps to remove unbound antibodies.[6][7][8]

Issue: Weak or no signal for target protein.

Potential Cause	Troubleshooting Steps
Low protein expression	Increase the amount of protein loaded onto the gel.
Inefficient protein transfer	Confirm successful transfer by staining the membrane with Ponceau S before blocking. Optimize transfer conditions (time, voltage) for your specific protein of interest.
Inactive antibody	Ensure antibodies have been stored correctly and have not expired. Use a positive control to verify antibody activity.

Experimental Protocols & Signaling Pathways

Experimental Workflow for Studying Anthramycin's Effects

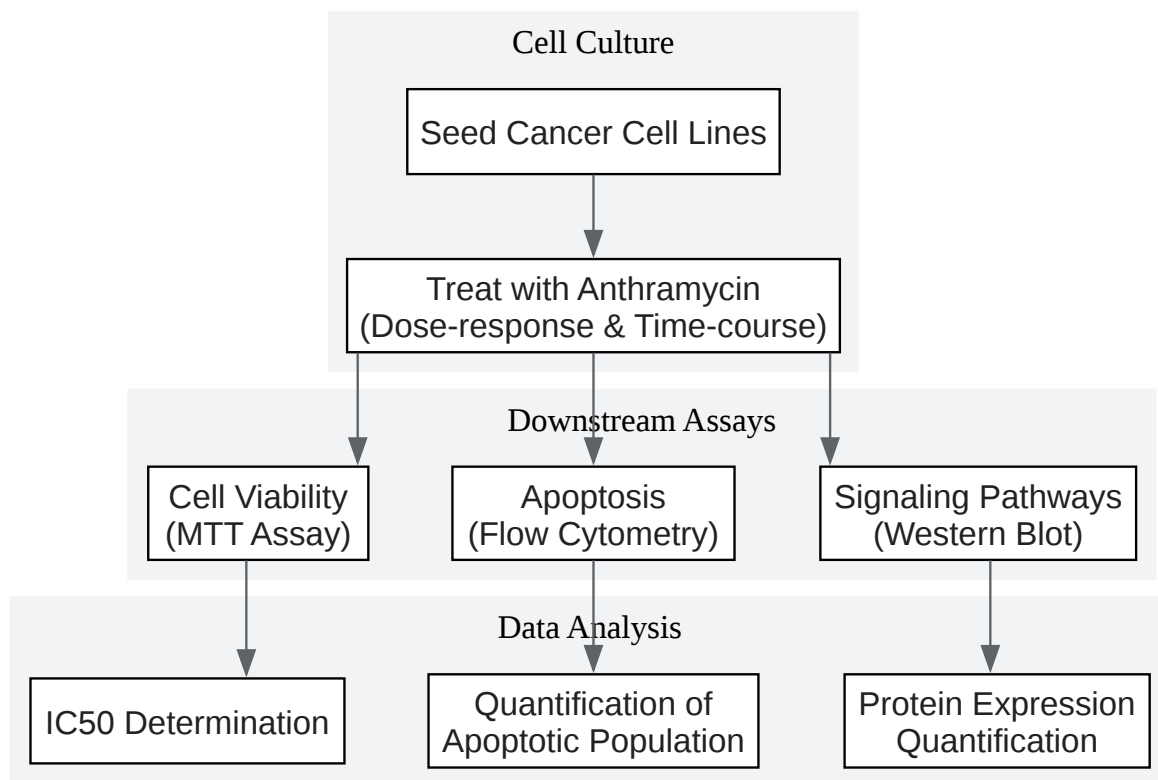

[Click to download full resolution via product page](#)

Fig. 1: Experimental workflow for assessing cell line-specific responses to anthramycin.

Anthramycin-Induced DNA Damage Response

Anthramycin's interaction with DNA can trigger the DNA Damage Response (DDR) pathway. This often involves the activation of the ATM (Ataxia-Telangiectasia Mutated) and Chk2 (Checkpoint Kinase 2) signaling cascade, leading to cell cycle arrest and apoptosis.

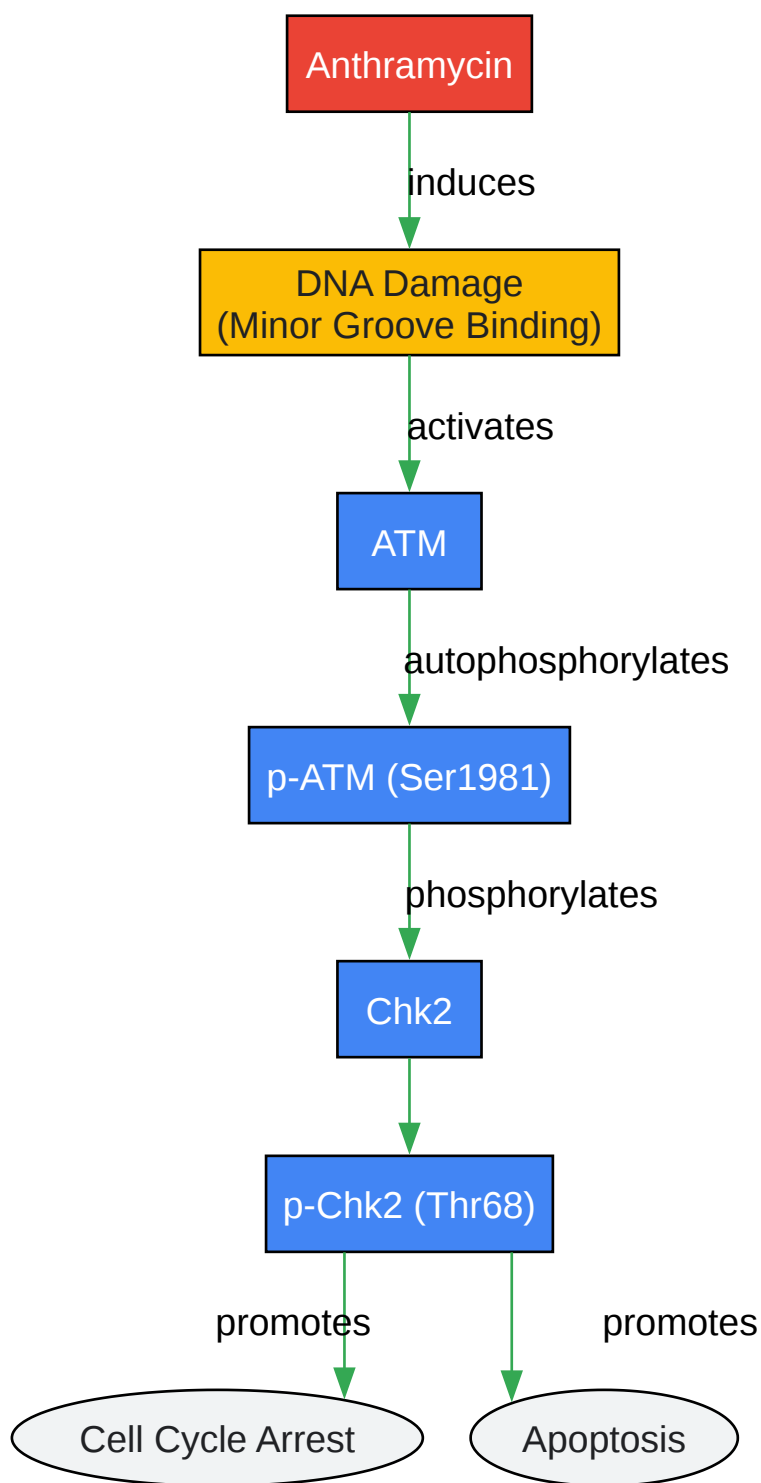

[Click to download full resolution via product page](#)

Fig. 2: Anthramycin-induced DNA damage response pathway.

Anthramycin and NF- κ B Signaling

Anthracycline treatment may also lead to the activation of the NF- κ B (Nuclear Factor kappa-light-chain-enhancer of activated B cells) signaling pathway, which is involved in regulating inflammation, cell survival, and proliferation. A key step in this pathway is the nuclear translocation of the p65 subunit.

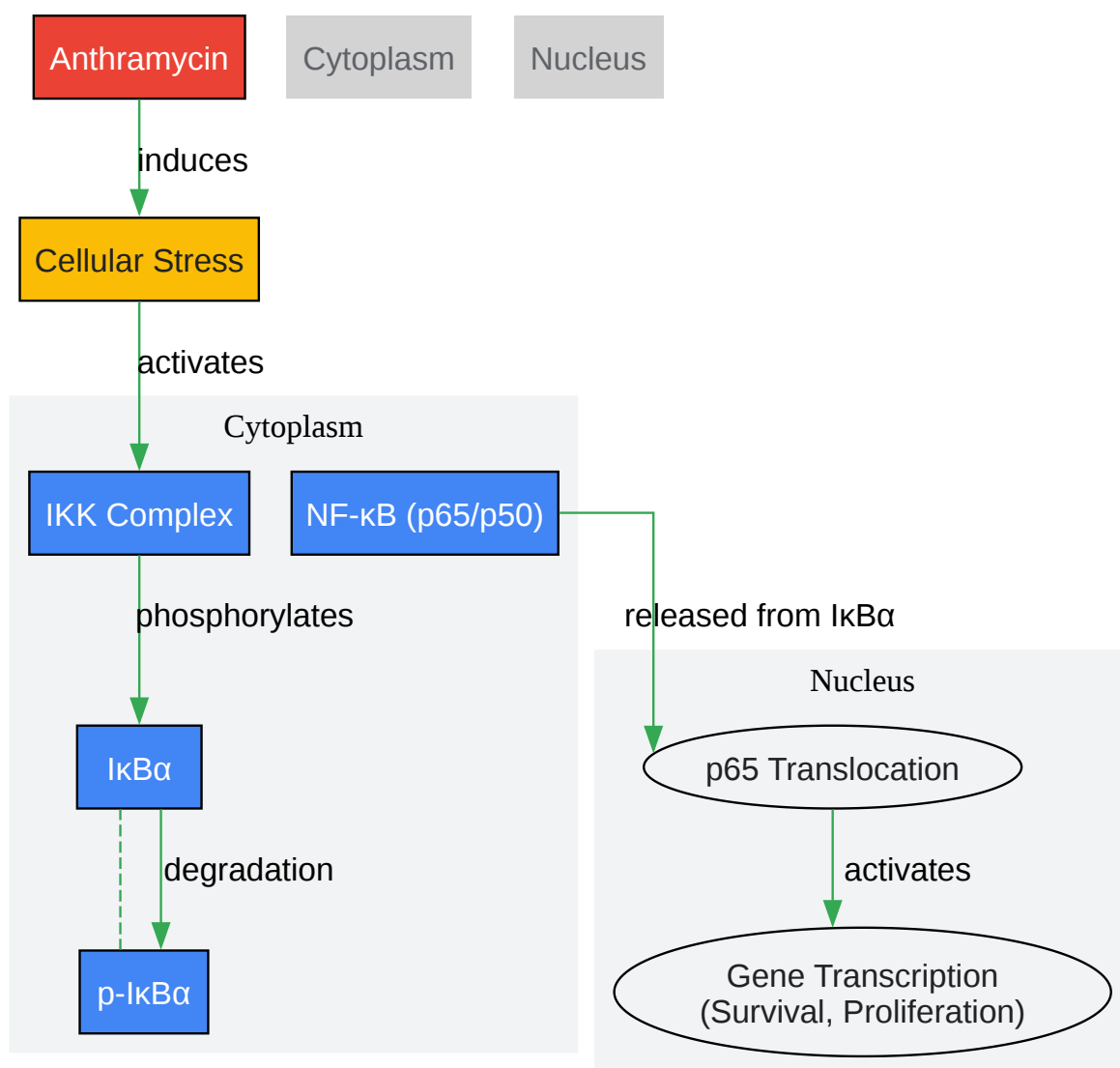

[Click to download full resolution via product page](#)

Fig. 3: Anthracycline's potential effect on the NF- κ B signaling pathway.

Detailed Experimental Protocols

- **Cell Seeding:** Seed cells in a 96-well plate at a pre-determined optimal density (e.g., 5,000-10,000 cells/well) in 100 μ L of complete culture medium. Incubate for 24 hours to allow for cell attachment.
- **Compound Treatment:** Prepare serial dilutions of anthramycin in culture medium. Replace the existing medium with 100 μ L of medium containing the desired concentrations of anthramycin. Include vehicle-only (e.g., DMSO) controls.
- **Incubation:** Incubate the plate for the desired treatment period (e.g., 24, 48, or 72 hours).
- **MTT Addition:** Add 10 μ L of 5 mg/mL MTT solution to each well and incubate for 2-4 hours at 37°C until purple formazan crystals are visible.
- **Formazan Solubilization:** Carefully remove the MTT-containing medium and add 100 μ L of DMSO to each well to dissolve the formazan crystals.
- **Absorbance Measurement:** Measure the absorbance at 570 nm using a microplate reader.
- **Data Analysis:** Calculate the percentage of cell viability relative to the vehicle-treated control and plot a dose-response curve to determine the IC50 value.
- **Cell Treatment:** Treat cells with the desired concentrations of anthramycin for the determined optimal time.
- **Cell Harvesting:** Collect both the culture supernatant (containing detached apoptotic cells) and the adherent cells (after gentle trypsinization).
- **Washing:** Wash the cells twice with cold PBS by centrifugation (e.g., 300 x g for 5 minutes).
- **Staining:** Resuspend the cell pellet in 1X Annexin V binding buffer. Add fluorescently labeled Annexin V and Propidium Iodide (PI) according to the manufacturer's protocol.
- **Incubation:** Incubate the cells in the dark at room temperature for 15 minutes.
- **Analysis:** Analyze the samples on a flow cytometer. Viable cells will be Annexin V-negative and PI-negative; early apoptotic cells will be Annexin V-positive and PI-negative; late apoptotic/necrotic cells will be Annexin V-positive and PI-positive.[3]

- Cell Lysis: After treatment with anthramycin, wash cells with cold PBS and lyse them in RIPA buffer containing protease and phosphatase inhibitors.
- Protein Quantification: Determine the protein concentration of the lysates using a BCA assay.
- SDS-PAGE: Denature equal amounts of protein (e.g., 20-30 μg) in Laemmli buffer and separate them on an SDS-polyacrylamide gel.
- Protein Transfer: Transfer the separated proteins to a PVDF or nitrocellulose membrane.
- Blocking: Block the membrane with 5% non-fat dry milk or BSA in TBST for 1 hour at room temperature.
- Primary Antibody Incubation: Incubate the membrane with primary antibodies against total and phosphorylated forms of target proteins (e.g., p-ATM Ser1981, p-Chk2 Thr68) overnight at 4°C.
- Secondary Antibody Incubation: Wash the membrane and incubate with an appropriate HRP-conjugated secondary antibody for 1 hour at room temperature.
- Detection: Visualize the protein bands using an enhanced chemiluminescence (ECL) substrate and an imaging system.
- Analysis: Quantify the band intensities and normalize the levels of phosphorylated proteins to their total protein levels.

Need Custom Synthesis?

BenchChem offers custom synthesis for rare earth carbides and specific isotopic labeling.

Email: info@benchchem.com or [Request Quote Online](#).

References

- [1. Anthramycin - Wikipedia \[en.wikipedia.org\]](#)
- [2. Assessment of Cell Viability in Drug Therapy: IC50 and Other New Time-Independent Indices for Evaluating Chemotherapy Efficacy - PMC \[pmc.ncbi.nlm.nih.gov\]](#)

- [3. benchchem.com \[benchchem.com\]](#)
- [4. DNA Damage-Induced Cell Cycle Regulation and Function of Novel Chk2 Phosphoresidues - PMC \[pmc.ncbi.nlm.nih.gov\]](#)
- [5. benchchem.com \[benchchem.com\]](#)
- [6. Western Blot Troubleshooting | Thermo Fisher Scientific - FR \[thermofisher.com\]](#)
- [7. southernbiotech.com \[southernbiotech.com\]](#)
- [8. bosterbio.com \[bosterbio.com\]](#)
- To cite this document: BenchChem. [Technical Support Center: Cell Line-Specific Responses to Anthramycin Treatment]. BenchChem, [2026]. [Online PDF]. Available at: [\[https://www.benchchem.com/product/b15606372/docs#technical-support-center-cell-line-specific-responses-to-anthramycin-treatment\]](https://www.benchchem.com/product/b15606372/docs#technical-support-center-cell-line-specific-responses-to-anthramycin-treatment)

Disclaimer & Data Validity:

The information provided in this document is for Research Use Only (RUO) and is strictly not intended for diagnostic or therapeutic procedures. While BenchChem strives to provide accurate protocols, we make no warranties, express or implied, regarding the fitness of this product for every specific experimental setup.

Technical Support: The protocols provided are for reference purposes. Unsure if this reagent suits your experiment?

Need Industrial/Bulk Grade? [Request Custom Synthesis Quote](#)

BenchChem

Our mission is to be the trusted global source of essential and advanced chemicals, empowering scientists and researchers to drive progress in science and industry.

Contact

Address: 3281 E Guasti Rd

Ontario, CA 91761, United States

Phone: (601) 213-4426

Email: info@benchchem.com

Contact our Ph.D. Support Team for a compatibility check