

# Technical Support Center: ATN-161 Treatment Optimization

**Author:** BenchChem Technical Support Team. **Date:** April 2026

## Compound of Interest

Compound Name: ATN-161 trifluoroacetate salt

Cat. No.: B15606112

[Get Quote](#)

This technical support center provides troubleshooting guides and frequently asked questions (FAQs) for researchers utilizing ATN-161. The information is designed to assist in optimizing experimental design for the most effective inhibition of cellular processes.

## Frequently Asked Questions (FAQs)

Q1: What is the primary mechanism of action for ATN-161?

A1: ATN-161 is a small peptide antagonist of integrins, primarily targeting  $\alpha 5\beta 1$  and  $\alpha v\beta 3$ .<sup>[1]</sup> It functions by binding to these integrins, which can lock them in an inactive conformation.<sup>[1]</sup> This interaction disrupts downstream signaling pathways crucial for cell adhesion, migration, proliferation, and angiogenesis.<sup>[2][3]</sup>

Q2: What is a recommended starting concentration and treatment time for ATN-161 in vitro?

A2: The optimal concentration and treatment time for ATN-161 are highly dependent on the cell type and the specific biological process being investigated. For initial experiments, a dose-response curve is recommended. However, based on published studies, a common starting point for in vitro assays is in the range of 1-100  $\mu\text{M}$ . For signaling pathway analysis, treatment times can be as short as 15-60 minutes.<sup>[3]</sup> For functional assays such as migration or tube

formation, pre-incubation for 30 minutes followed by an assay duration of 4-24 hours is a good starting point. For longer-term experiments like assessing cell viability or apoptosis, treatment times can extend up to 48 hours or longer.[3]

Q3: I am not observing an inhibitory effect with ATN-161. What are some potential troubleshooting steps?

A3: If you are not seeing the expected inhibition, consider the following:

- **Cell Type:** Confirm that your cell line expresses the target integrins ( $\alpha 5\beta 1$  and/or  $\alpha v\beta 3$ ) at sufficient levels.
- **Concentration:** Perform a dose-response experiment to determine the optimal concentration for your specific cell line and assay. In some preclinical models, ATN-161 has exhibited a U-shaped dose-response curve, where higher concentrations can be less effective than optimal intermediate doses.
- **Treatment Time:** The kinetics of inhibition can vary. For signaling studies, short time points (e.g., 15, 30, 60 minutes) are crucial. For functional assays, ensure the treatment duration is appropriate for the biological process being measured (e.g., 4-24 hours for migration).
- **Peptide Integrity:** Ensure the ATN-161 peptide is properly stored and handled to maintain its activity.
- **Assay Conditions:** Optimize your assay conditions, including cell density, serum concentration, and the type of extracellular matrix coating used, as these can all influence integrin-mediated signaling.

## Troubleshooting Guides by Assay

### Signaling Pathway Analysis (e.g., Western Blot for p-MAPK, p-FAK)

Issue: No change or inconsistent changes in phosphorylation of downstream targets.

- **Recommended Time Course:** For initial experiments, a time course of 15, 30, 60, and 120 minutes is recommended. Maximal inhibition of MAPK phosphorylation has been observed

at 30 minutes in MDA-MB-231 cells.[3]

- Serum Starvation: Ensure cells are adequately serum-starved prior to ATN-161 treatment to reduce basal signaling. A common practice is overnight serum starvation.[3]
- Stimulation: If investigating the inhibition of a growth factor-induced signal, add ATN-161 prior to stimulation. A 30-minute pre-incubation with ATN-161 is a good starting point.

## Cell Migration and Invasion Assays

Issue: No significant inhibition of cell migration or invasion.

- Pre-incubation: Pre-incubating cells with ATN-161 for at least 30 minutes before seeding them into the migration chamber can enhance the inhibitory effect.
- Assay Duration: Typical migration and invasion assays run for 4 to 24 hours. The optimal time will depend on the migratory speed of your cells.
- Chemoattractant: Ensure the chemoattractant used is appropriate for your cell type and that a clear gradient is established.
- Extracellular Matrix (for invasion assays): The type and concentration of the extracellular matrix (e.g., Matrigel) can influence the results. Ensure the coating is consistent.

## Endothelial Cell Tube Formation Assay

Issue: ATN-161 is not inhibiting tube formation.

- Assay Duration: Tube formation is a dynamic process. Observe the tubes at several time points (e.g., 4, 8, and 12 hours) to capture the optimal window of inhibition.
- Matrix Quality: Use a high-quality basement membrane matrix (e.g., Matrigel) and ensure it is properly thawed and polymerized.
- Cell Density: The initial seeding density of endothelial cells is critical for robust tube formation.

## Apoptosis Assays

Issue: No increase in apoptosis with ATN-161 treatment.

- **Treatment Duration:** Induction of apoptosis can be a slower process. Consider longer incubation times, such as 24 to 72 hours. In some in vivo models, effects on apoptosis were observed after several days of treatment.[\[2\]](#)
- **Assay Method:** Use multiple methods to confirm apoptosis (e.g., Annexin V/PI staining, caspase activity assays, TUNEL).
- **Combination Treatment:** In some systems, ATN-161 may be more effective at inducing apoptosis when combined with other agents, such as chemotherapy.

## Data Summary

### Effective Concentrations and Treatment Times of ATN-161 in In Vitro Studies

Assay Type	Cell Line	Concentration Range	Treatment Time	Observed Effect
MAPK Phosphorylation	MDA-MB-231	1 - 100 $\mu$ M	15 - 60 min	Maximal inhibition at 20 $\mu$ M after 30 min
FAK Phosphorylation	MDA-MB-231	1 - 100 $\mu$ M	15 - 60 min	Inhibition observed
Cell Proliferation	Human Choroidal Endothelial Cells (hCECs)	1 nM - 100 $\mu$ M	24 hours	No significant inhibition
Cell Migration	Human Choroidal Endothelial Cells (hCECs)	1 nM - 100 $\mu$ M	24 hours	Dose-dependent inhibition
Tube Formation	Human Choroidal Endothelial Cells (hCECs)	Not specified	4 - 12 hours	Inhibition of VEGF-induced tube formation
Apoptosis (Cell Number)	Endothelial Cells	Not specified	48 hours	21% decrease in cell number

## Experimental Protocols

### Western Blot for Phosphorylated Kinases

- Cell Culture and Treatment: Plate cells (e.g., MDA-MB-231) in complete medium. Once they reach 70-80% confluency, serum-starve them overnight.[3]
- Treat cells with varying concentrations of ATN-161 (e.g., 1, 10, 20, 50, 100  $\mu$ M) for different time points (e.g., 15, 30, 60, 120 minutes).[3] A vehicle-treated control should be included.
- Lysis: Immediately after treatment, wash the cells with ice-cold PBS and lyse them in RIPA buffer supplemented with protease and phosphatase inhibitors.

- **Protein Quantification:** Determine the protein concentration of each lysate using a BCA assay.
- **SDS-PAGE and Transfer:** Load equal amounts of protein onto an SDS-PAGE gel, run the gel, and transfer the proteins to a PVDF membrane.
- **Immunoblotting:** Block the membrane with 5% BSA or non-fat milk in TBST for 1 hour at room temperature.
- **Incubate the membrane with primary antibodies** against the phosphorylated and total forms of the kinases of interest (e.g., p-MAPK, MAPK, p-FAK, FAK) overnight at 4°C.
- **Wash the membrane with TBST and incubate with the appropriate HRP-conjugated secondary antibody** for 1 hour at room temperature.
- **Detection:** Visualize the protein bands using an enhanced chemiluminescence (ECL) detection system.

## Transwell Cell Migration Assay

- **Cell Preparation:** Culture cells to 70-80% confluency. Serum-starve the cells overnight.
- **Harvest the cells** using a non-enzymatic cell dissociation solution and resuspend them in a serum-free medium at a desired concentration (e.g.,  $1 \times 10^5$  cells/mL).
- **ATN-161 Pre-incubation:** Incubate the cell suspension with the desired concentrations of ATN-161 or vehicle control for 30 minutes at 37°C.
- **Assay Setup:** Add a chemoattractant (e.g., medium with 10% FBS) to the lower chamber of a transwell plate.
- **Seed the pre-incubated cell suspension** into the upper chamber (the insert).
- **Incubation:** Incubate the plate at 37°C in a CO2 incubator for a period determined by the cell type's migratory rate (typically 4-24 hours).
- **Analysis:** After incubation, remove the non-migrated cells from the top of the insert with a cotton swab.

- Fix the migrated cells on the bottom of the membrane with methanol and stain them with a solution like crystal violet.
- Count the number of migrated cells in several fields of view under a microscope.

## Endothelial Cell Tube Formation Assay

- **Matrix Coating:** Thaw a basement membrane matrix (e.g., Matrigel) on ice and coat the wells of a 96-well plate. Allow the matrix to solidify at 37°C for 30-60 minutes.
- **Cell Preparation:** Harvest endothelial cells and resuspend them in a serum-free or low-serum medium.
- **Treatment:** Add ATN-161 at various concentrations to the cell suspension.
- **Seeding:** Seed the cell suspension onto the solidified matrix.
- **Incubation:** Incubate the plate at 37°C in a CO2 incubator and monitor for tube formation at different time points (e.g., 4, 8, 12 hours).
- **Analysis:** Capture images of the tube-like structures using a microscope. The extent of tube formation can be quantified by measuring parameters such as the total tube length, number of junctions, and number of loops using image analysis software.

## Visualizations

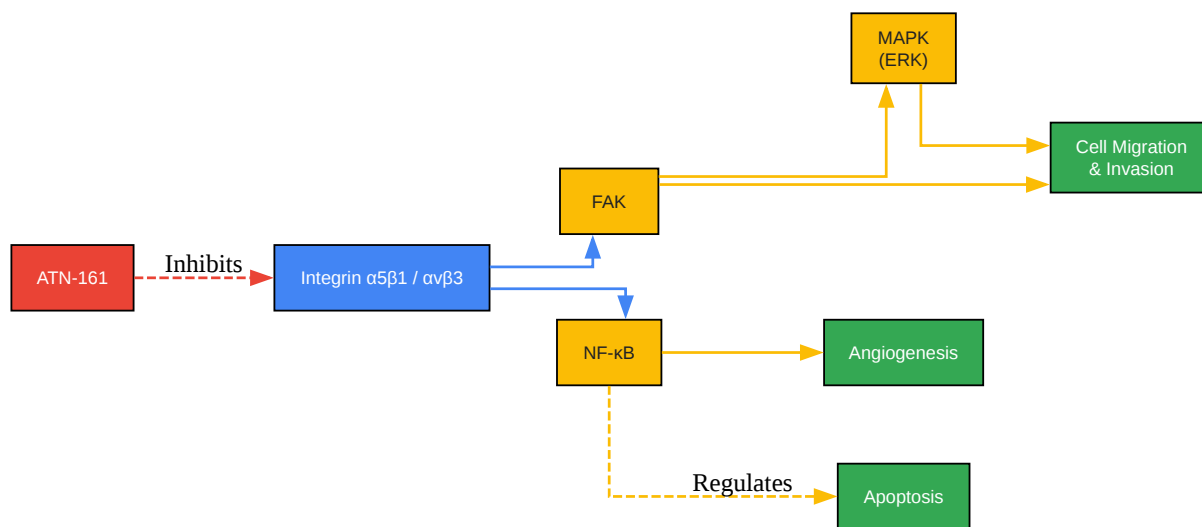

[Click to download full resolution via product page](#)

Caption: Simplified signaling pathway of ATN-161 action.

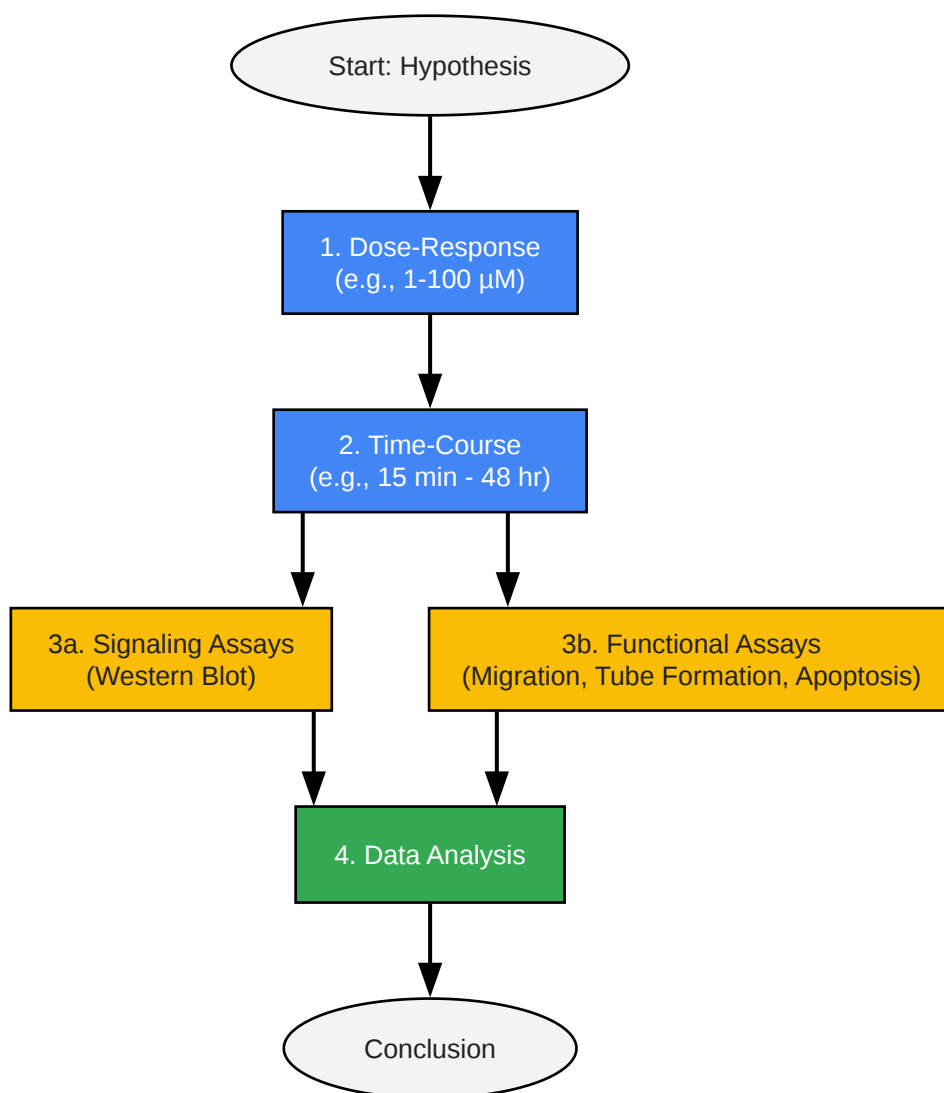

[Click to download full resolution via product page](#)

Caption: General workflow for optimizing ATN-161 treatment.

### Need Custom Synthesis?

BenchChem offers custom synthesis for rare earth carbides and specific isotopic labeling.

Email: [info@benchchem.com](mailto:info@benchchem.com) or [Request Quote Online](#).

## References

- 1. [iovs.arvojournals.org](https://iovs.arvojournals.org) [[iovs.arvojournals.org](https://iovs.arvojournals.org)]

- [2. ATN-161 as an Integrin  \$\alpha 5\beta 1\$  Antagonist Depresses Ocular Neovascularization by Promoting New Vascular Endothelial Cell Apoptosis - PMC \[pmc.ncbi.nlm.nih.gov\]](#)
- [3. medchemexpress.com \[medchemexpress.com\]](#)
- To cite this document: BenchChem. [Technical Support Center: ATN-161 Treatment Optimization]. BenchChem, [2026]. [Online PDF]. Available at: [<https://www.benchchem.com/product/b15606112/docs#technical-support-center-atn-161-treatment-optimization>]

---

### Disclaimer & Data Validity:

The information provided in this document is for Research Use Only (RUO) and is strictly not intended for diagnostic or therapeutic procedures. While BenchChem strives to provide accurate protocols, we make no warranties, express or implied, regarding the fitness of this product for every specific experimental setup.

**Technical Support:** The protocols provided are for reference purposes. Unsure if this reagent suits your experiment?

**Need Industrial/Bulk Grade?** [Request Custom Synthesis Quote](#)

## BenchChem

Our mission is to be the trusted global source of essential and advanced chemicals, empowering scientists and researchers to drive progress in science and industry.

### Contact

Address: 3281 E Guasti Rd  
Ontario, CA 91761, United States  
Phone: (601) 213-4426  
Email: [info@benchchem.com](mailto:info@benchchem.com)

[Contact our Ph.D. Support Team for a compatibility check](#)

