

# TDFA Technical Support Center: Low-Noise Operation

**Author:** BenchChem Technical Support Team. **Date:** April 2026

## Compound of Interest

Compound Name: TDFA  
Cat. No.: B15606691

[Get Quote](#)

This technical support center provides troubleshooting guidance and answers to frequently asked questions for researchers and scientists working with Thulium-Doped Fiber Amplifiers (TDFA), with a specific focus on achieving low-noise operation during experiments.

## Frequently Asked Questions (FAQs)

Q1: What is the Noise Figure (NF) in a TDFA and why is it critical?

A1: The Noise Figure (NF) is a measure of the degradation of the signal-to-noise ratio (SNR) as a signal passes through the amplifier. It quantifies the amount of noise added by the amplifier itself. In sensitive applications, a low noise figure is critical to ensure that the amplified signal is not obscured by the noise introduced by the amplification process, thereby maintaining signal clarity and integrity.

Q2: What are the primary factors influencing the noise figure in a TDFA?

A2: The primary factors influencing the TDFA noise figure are the choice of pump wavelength, pump power, and pumping direction (forward, backward, or bidirectional).<sup>[1][2]</sup> Additionally, the length of the thulium-doped fiber, the concentration of thulium ions, and losses from passive components like couplers and isolators can impact noise performance.<sup>[3]</sup>

Q3: How does the choice of pump wavelength affect the **TDFA's** noise performance?

A3: The pump wavelength significantly impacts both the gain and noise figure of a **TDFA** by determining the efficiency of the population inversion. Studies have shown that for S-band amplification, pumping at 1050 nm or 1400 nm can result in lower noise figures compared to other common pump wavelengths like 800 nm and 1560 nm.[4][5] The 1050 nm pump wavelength is often considered the most efficient for achieving low noise in S-band **TDFAs**. [4] [5]

Q4: What is Amplified Spontaneous Emission (ASE) and how does it contribute to the noise figure?

A4: Amplified Spontaneous Emission (ASE) is noise generated within the amplifier when thulium ions, excited by the pump laser, decay spontaneously and emit photons. These photons are then amplified along with the signal, creating a broad spectrum of noise. This ASE is the dominant contribution to the amplifier's noise figure. The interpolation method, which measures the ASE level on either side of the amplified signal, is a common technique used by Optical Spectrum Analyzers (OSAs) to calculate the noise figure.[6]

Q5: How do pump power and direction influence the noise figure?

A5: Both pump power and its direction affect the level of population inversion along the fiber, which in turn influences gain and noise.

- **Pump Power:** Increasing pump power generally increases gain, but after a certain point, the noise figure may also begin to increase. There is often an optimal pump power that provides a good balance between high gain and a low noise figure.[5]
- **Pumping Direction:** The direction of the pump (co-propagating or forward-pumped, counter-propagating or backward-pumped, or bidirectional) alters the gain and ASE distribution along the fiber. Backward pumping has been shown to offer higher gain at higher pump powers (above 600 mW) in some configurations.[4] The optimal configuration depends on the specific design and application requirements.

## Troubleshooting Guide

This guide addresses common issues encountered during **TDFAs** experiments in a question-and-answer format.

Problem: My **TDFAs** exhibits a higher-than-expected noise figure.

- Possible Causes & Solutions:
  - Suboptimal Pump Wavelength: You may be using a pump wavelength that is not ideal for low-noise operation.
    - Action: If your setup allows, switch to a more efficient pump wavelength. For S-band **TDFAs**, 1050 nm is often the most effective choice for low noise.[4][5]
  - Incorrect Pump Power: The pump power might be too high or too low, moving you out of the optimal operating range.
    - Action: Vary the pump power and measure the noise figure at each step to find the optimal power level for your specific fiber length and input signal.[5]
  - Component-Induced Losses: High insertion loss from dirty or damaged connectors, poor splices, or faulty passive components (isolators, WDM couplers) can degrade the input signal and effectively increase the noise figure.
    - Action: Inspect and clean all fiber optic connectors.[7][8] Use an optical power meter to check for unexpected losses at each connection point. Ensure splices are of high quality.
  - Reflections in the System: Back reflections from unterminated fiber ends or faulty components can cause instabilities and increase noise.
    - Action: Ensure all unused ports are properly terminated and that isolators are functioning correctly to prevent back reflections.

Problem: The gain is too low, resulting in a poor Optical Signal-to-Noise Ratio (OSNR).

- Possible Causes & Solutions:

- Insufficient Pump Power: The pump power may be inadequate to achieve the necessary population inversion for high gain.
  - Action: Gradually increase the pump power while monitoring the gain. Note that for some designs, gain continues to increase with pump powers up to 1600 mW and beyond.[4]
- Incorrect Fiber Length: The length of the thulium-doped fiber may be too short for the available pump power or not optimized for the signal wavelength.
  - Action: If possible, experiment with different lengths of the active fiber to find the optimal length for your target gain and noise performance.[3]
- Low Input Signal Power: The input signal may be below the amplifier's optimal operating range.
  - Action: Check the input signal power with a calibrated optical power meter to ensure it is within the specified range for your **TDFA**. [9]

Problem: The **TDFA** output power is unstable or oscillating.

- Possible Causes & Solutions:
  - Back Reflections: This is a common cause of laser instabilities and oscillations.
    - Action: Verify the integrity of your optical isolators. Check the entire optical path for sources of reflection, such as air gaps at connectors or damaged fiber ends.
  - Unstable Pump Laser: The pump laser itself may have an unstable output.
    - Action: Monitor the pump laser's output power directly to ensure it is stable. Check the laser's temperature and current settings to confirm they are within normal operating limits.[9]
  - Environmental Factors: Temperature fluctuations can affect the performance of the doped fiber and other components.[7]
    - Action: Ensure the **TDFA** and its components are in a thermally stable environment.

## Quantitative Data Summary

The following tables summarize key performance data from experimental studies on **TDFAs**.

Table 1: Effect of Pump Wavelength on **T DFA** Gain and Noise Figure

Pump Wavelength	Average Gain (dB)	Average Noise Figure (dB)	Notes
800 nm	Lower	Higher	Commonly used but less efficient for low-noise S-band operation.[4]
1050 nm	Highest	Lowest	Often the most efficient pump wavelength for S-band TDFAs.[4][5]
1400 nm	High	Low	Provides low noise figures, comparable to 1050 nm pumping.[4]
1560 nm	Moderate	Higher	Another possible pump wavelength, though less efficient than 1050 nm.[4]

Data is generalized from comparative studies.[1][2][4][5] Absolute values depend on specific fiber length, pump power, and amplifier design.

Table 2: Effect of Pump Power on Gain and Noise Figure (1050 nm Pump)

Pump Power (mW)	Approximate Gain (dB)	Approximate Noise Figure (dB)
200	~15	~5.5
600	~25	~5.0
1000	~30	~5.2
1600	~35	~5.8
2000	~38	~6.2

Values are illustrative based on trends observed in double-stage backward-pumped **TDFA** designs at 1469 nm and can vary significantly with amplifier configuration.[4]

## Visualizations and Diagrams

### Thulium ( $Tm^{3+}$ ) Energy Level Diagram

This diagram illustrates the key energy transitions in a Thulium ion relevant for S-band amplification. Pumping at 1050 nm or 1400 nm excites ions to higher energy levels. The signal amplification occurs on the  $^3H_4 \rightarrow ^3F_4$  transition. Spontaneous decay from the  $^3H_4$  level is a primary source of ASE noise.

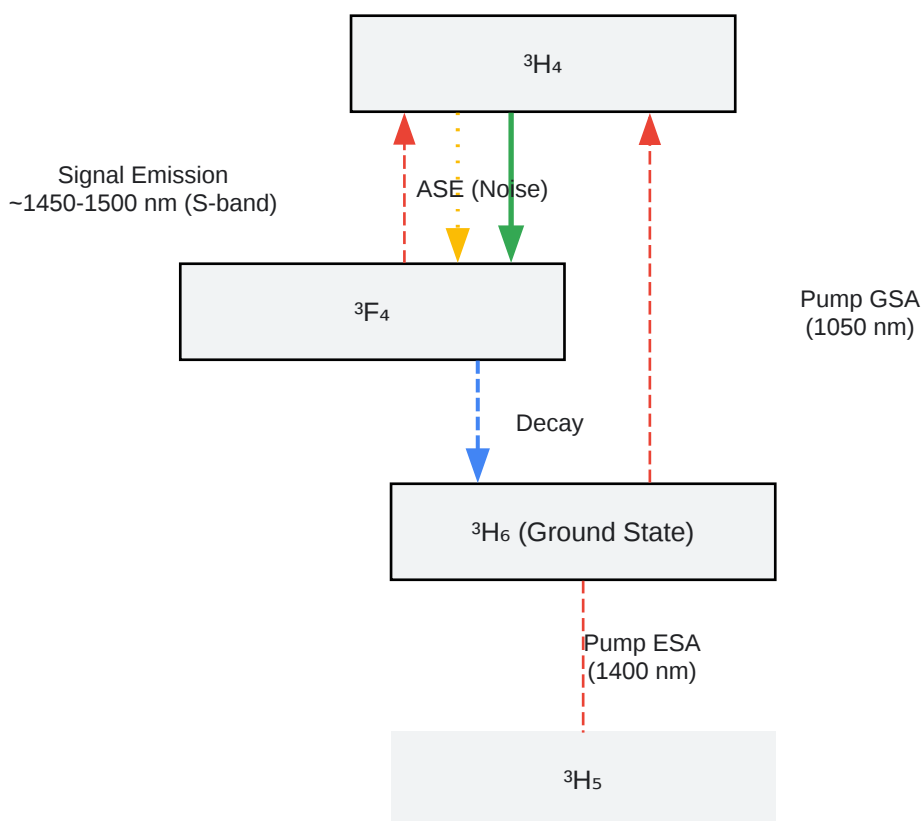

[Click to download full resolution via product page](#)

Caption: Thulium (Tm<sup>3+</sup>) energy levels for S-band amplification.

## Troubleshooting Workflow for High Noise Figure

This workflow provides a logical sequence of steps to diagnose and resolve issues of high noise figure in a **TDFA** setup.

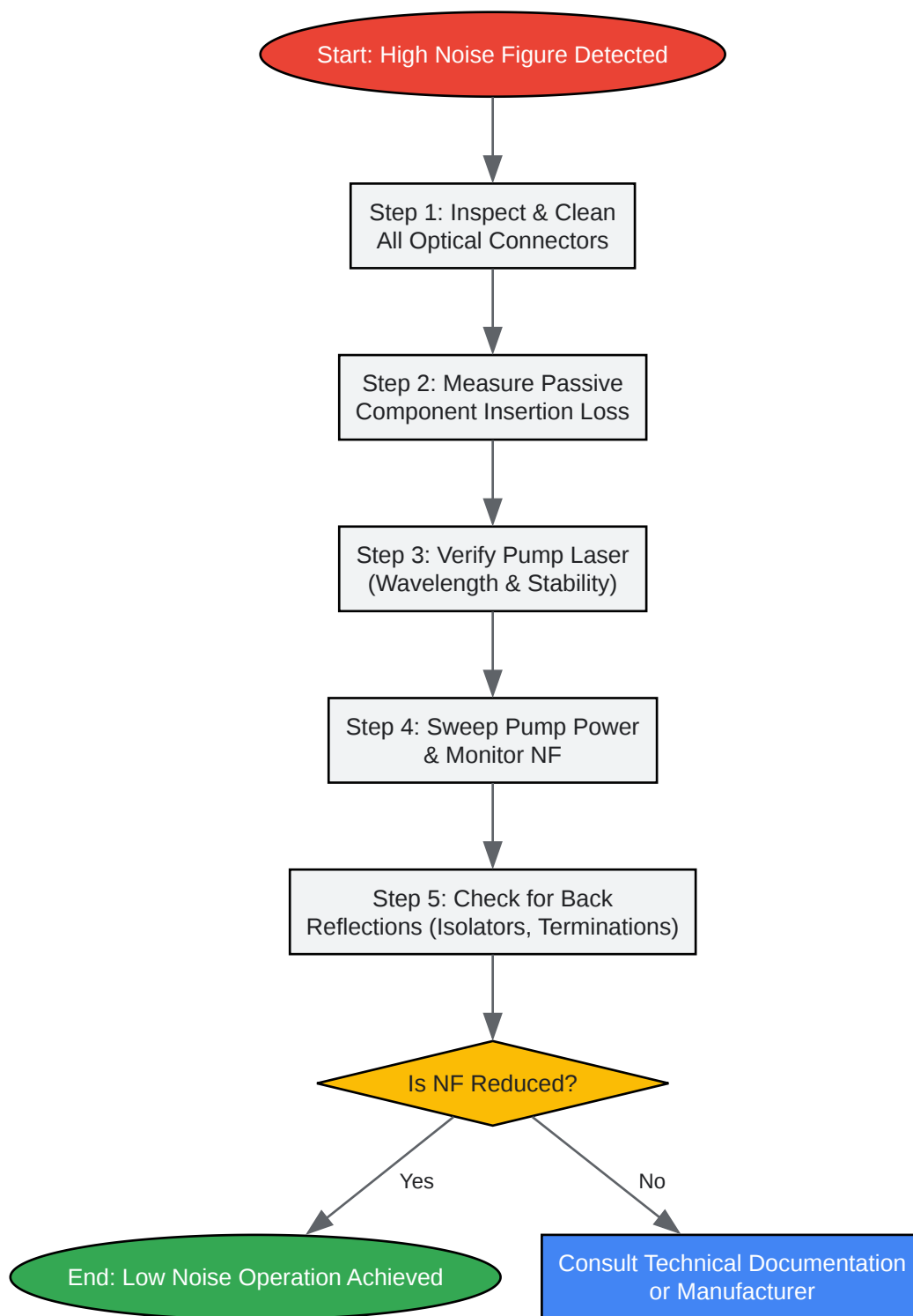

[Click to download full resolution via product page](#)

Caption: Troubleshooting workflow for high **TDFA** noise figure.

## Experimental Protocols

## Methodology: Measuring TDFA Noise Figure

This protocol outlines the steps to measure the noise figure of a **TDFA** using the common interpolation or source subtraction technique with an Optical Spectrum Analyzer (OSA).[6]

Required Equipment:

- Tunable Laser Source (TLS) or other stable signal source
- Thulium-Doped Fiber Amplifier (**TDFA**) under test
- Optical Spectrum Analyzer (OSA) with Noise Figure measurement capability
- Optical Power Meter
- Optical Attenuator
- Necessary fiber optic patch cords and connectors

Experimental Workflow Diagram

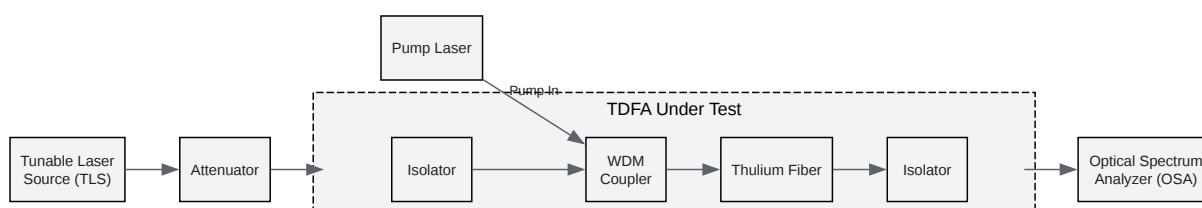

[Click to download full resolution via product page](#)

Caption: Experimental setup for **TDFA** gain and noise figure measurement.

Step-by-Step Procedure:

- **System Calibration:** Calibrate the OSA and power meter according to the manufacturer's instructions. Account for the insertion loss of patch cords and connectors between the

amplifier and the OSA. Many OSAs allow you to input these attenuation values directly.[6]

- **Setup Assembly:** Connect the components as shown in the experimental setup diagram. Ensure the input isolator is placed before the WDM coupler and the output isolator is placed after the active fiber to prevent oscillations.
- **Set Input Signal:** Turn on the Tunable Laser Source and set it to the desired wavelength within the **TDFA**'s operating range (e.g., S-band). Use the optical attenuator to adjust the input signal power to the desired level (e.g., -20 dBm).[3]
- **Power On Amplifier:** Turn on the pump laser and set it to the desired power level. Allow the system to stabilize for several minutes.
- **Acquire OSA Trace:** Use the OSA to capture the output spectrum of the **TDFA**. You should see the amplified signal peak and the broad ASE noise spectrum.
- **Measure Noise Figure:**
  - Engage the automated Noise Figure (NF) measurement function on the OSA.
  - The OSA will typically use the interpolation method: it measures the ASE power level on both sides of the signal peak (e.g., 0.5 nm or 1 nm away) and interpolates to find the ASE power directly at the signal wavelength.[6]
  - The instrument then calculates the noise figure based on this ASE level, the measured gain, and the resolution bandwidth.
- **Record Data:** Record the measured gain and noise figure for the specific input signal wavelength, input power, and pump power.
- **Repeat Measurements:** Repeat steps 3-7 for different wavelengths, input powers, and pump powers to fully characterize the low-noise performance of your **TDFA**.

#### ***Need Custom Synthesis?***

*BenchChem offers custom synthesis for rare earth carbides and specific isotopic labeling.*

*Email: [info@benchchem.com](mailto:info@benchchem.com) or [Request Quote Online](#).*

## References

- [1. OAM-RC :: Articles \[oam-rc.inoe.ro\]](#)
- [2. The effect of pump wavelength, power and direction on gain and noise figure in double-pass/stage TDFAs | AVESİS \[avesis.gazi.edu.tr\]](#)
- [3. researchgate.net \[researchgate.net\]](#)
- [4. oam-rc.inoe.ro \[oam-rc.inoe.ro\]](#)
- [5. researchgate.net \[researchgate.net\]](#)
- [6. exfo.com \[exfo.com\]](#)
- [7. Troubleshooting Common Issues in Optical Fiber Networks - Elevating Your Project Profits with Superior Fiber Optic Patch Cords \[ftthfiber optic.com\]](#)
- [8. Common Optical Transceiver Failures and Effective Troubleshooting Solutions \[link-pp.com\]](#)
- [9. fiber-mart.com \[fiber-mart.com\]](#)
- To cite this document: BenchChem. [T DFA Technical Support Center: Low-Noise Operation]. BenchChem, [2026]. [Online PDF]. Available at: [\[https://www.benchchem.com/product/b15606691/docs#tdfa-technical-support-center-low-noise-operation\]](https://www.benchchem.com/product/b15606691/docs#tdfa-technical-support-center-low-noise-operation)

---

### Disclaimer & Data Validity:

The information provided in this document is for Research Use Only (RUO) and is strictly not intended for diagnostic or therapeutic procedures. While BenchChem strives to provide accurate protocols, we make no warranties, express or implied, regarding the fitness of this product for every specific experimental setup.

**Technical Support:** The protocols provided are for reference purposes. Unsure if this reagent suits your experiment?

**Need Industrial/Bulk Grade?** [Request Custom Synthesis Quote](#)

# BenchChem

Our mission is to be the trusted global source of essential and advanced chemicals, empowering scientists and researchers to drive progress in science and industry.

## Contact

Address: 3281 E Guasti Rd

Ontario, CA 91761, United States

Phone: (601) 213-4426

Email: [info@benchchem.com](mailto:info@benchchem.com)

[Contact our Ph.D. Support Team for a compatibility check](#)