

Quantitative Analysis of Ki-67 Expression in Tumors: Application Notes and Protocols

Author: BenchChem Technical Support Team. **Date:** April 2026

Compound of Interest

Compound Name: K67
Cat. No.: B15606711

[Get Quote](#)

For Researchers, Scientists, and Drug Development Professionals

Introduction

The Ki-67 protein is a nuclear marker strictly associated with cell proliferation. Its expression is detectable in all active phases of the cell cycle (G1, S, G2, and M) but absent in quiescent cells (G0).[1] This characteristic has established Ki-67 as a crucial biomarker in oncology for assessing the proliferative activity of tumors. The Ki-67 labeling index (LI), representing the percentage of Ki-67-positive tumor cells, is a valuable prognostic and predictive tool in various malignancies, aiding in therapeutic decision-making.[2]

This document provides detailed application notes and protocols for the quantitative analysis of Ki-67 expression in tumor tissues, encompassing both traditional immunohistochemistry (IHC) and modern digital image analysis (DIA) techniques.

Data Presentation: Quantitative Comparison of Ki-67 Scoring Methods

The accurate quantification of Ki-67 is paramount for its clinical utility. However, significant inter-observer variability exists with manual scoring methods.[1] Digital image analysis offers a more objective and reproducible alternative. The following tables summarize the concordance and performance of different Ki-67 scoring methods across various studies.

Table 1: Comparison of Inter-Observer Agreement for Different Ki-67 Scoring Methods in Breast Cancer

Scoring Method	Number of Observers	Agreement Metric	Value	Reference
Weighted Global Scoring	2	ICC	0.967	[3]
Hotspot Method (Manual)	2	ICC	0.951	[3]
Eye-10 Method (At a glance)	2	ICC	0.888	[3]
Average Method (without hotspots)	30	ICC	0.874 (95% CI: 0.761-0.959)	[4]
Average Method (with hotspots)	30	ICC	0.736 (95% CI: 0.559-0.904)	[4]
Hotspot Method (with hotspots)	30	ICC	0.737 (95% CI: 0.561-0.905)	[4]

ICC: Intraclass Correlation Coefficient

Table 2: Concordance between Manual and Digital Image Analysis (DIA) for Ki-67 Scoring

Tumor Type	Manual Method	DIA Platform/Method	Agreement Metric	Value	Reference
Breast Carcinoma	Pathologist Annotation (Global)	Not Specified	CCC	0.83	[5]
Breast Carcinoma	Pathologist Annotation (Hotspot)	Not Specified	CCC	0.77	[5]
Breast Carcinoma	Automated Tissue Detection (Global)	Not Specified	CCC	0.28	[5]
Breast Carcinoma	Visual Assessment (Pathologist 1)	Aperio Digital Scanner (Hotspot)	Mean Difference	0.1%	[6]
Breast Carcinoma	Visual Assessment (Pathologist 2)	Aperio Digital Scanner (Hotspot)	Mean Difference	3.2%	[6]
Breast Carcinoma	Manual Hotspot	DIA (QuPath & Visiopharm)	ICC	> 0.780	[7]

CCC: Concordance Correlation Coefficient; ICC: Intraclass Correlation Coefficient

Prognostic Value of Ki-67 Across Different Tumor Types

The Ki-67 proliferation index has demonstrated significant prognostic value in a variety of cancers. Higher Ki-67 expression is generally associated with a poorer prognosis.

Table 3: Prognostic Value of Ki-67 Expression in Various Cancers

Cancer Type	Number of Patients	Ki-67 Cut-off	Outcome	Hazard Ratio (HR)	95% Confidence Interval (CI)	p-value	Reference
Breast Cancer	64,196	≥25%	Overall Survival	2.05	1.66 - 2.53	< 0.00001	[2]
Breast Cancer (ER-positive)	Not Specified	High vs. Low	Overall Survival	1.51	1.25 - 1.81	< 0.0001	[2]
HR-negative Breast Cancer	Not Specified	>30%	Disease-Free Survival	2.31	1.03 - 4.43	0.024	[8]
HR-negative Breast Cancer	Not Specified	>30%	Overall Survival	3.05	1.15 - 6.42	0.038	[8]
Prostate Cancer	293	>10%	Cancer-Specific Death	3.42	1.76 - 6.62	0.002	[9]
Triple-Negative Breast Cancer	1146	>45%	Disease-Free Survival	Not Specified	Not Specified	0.038	
Triple-Negative Breast Cancer	1146	>45%	Overall Survival	Not Specified	Not Specified	0.028	

Experimental Protocols

Protocol 1: Ki-67 Immunohistochemistry (IHC) for Formalin-Fixed Paraffin-Embedded (FFPE) Tissues

This protocol provides a standardized method for the immunohistochemical staining of Ki-67 in FFPE tissue sections.

1. Materials and Reagents:

- FFPE tissue sections (4-5 μm) on positively charged slides
- Xylene or xylene substitute
- Ethanol (100%, 95%, 80%, 70%)
- Deionized water
- Antigen Retrieval Solution (e.g., 10mM Sodium Citrate Buffer, pH 6.0 or Tris-EDTA buffer, pH 9.0)
- 3% Hydrogen Peroxide
- Wash Buffer (e.g., Tris-buffered saline with 0.05% Tween-20, TBST)
- Blocking Buffer (e.g., 5% Bovine Serum Albumin in TBST)
- Primary Antibody: Anti-Ki-67 antibody (clone MIB-1 is commonly used)
- Secondary Antibody (HRP-conjugated)
- DAB (3,3'-Diaminobenzidine) Chromogen Kit
- Hematoxylin counterstain
- Mounting Medium

2. Deparaffinization and Rehydration:

- Incubate slides in an oven at 60-65°C for 30-60 minutes.
- Immerse slides in two changes of xylene for 5 minutes each.
- Immerse slides in two changes of 100% ethanol for 3 minutes each.
- Immerse slides in 95% ethanol for 3 minutes.
- Immerse slides in 70% ethanol for 3 minutes.
- Rinse slides in deionized water for 5 minutes.

3. Antigen Retrieval:

- Immerse slides in pre-heated Antigen Retrieval Solution.
- Heat the slides in a water bath or steamer at 95-100°C for 20-30 minutes.
- Allow slides to cool in the buffer for 20 minutes at room temperature.
- Rinse slides with deionized water and then with wash buffer.

4. Staining Procedure:

- Block endogenous peroxidase activity by incubating slides in 3% Hydrogen Peroxide for 10 minutes.
- Rinse slides with wash buffer.
- Apply Blocking Buffer and incubate for 30-60 minutes to prevent non-specific antibody binding.
- Drain the blocking solution and apply the primary anti-Ki-67 antibody diluted according to the manufacturer's instructions. Incubate overnight at 4°C in a humidified chamber.
- Rinse slides with wash buffer (3 changes, 5 minutes each).
- Apply the HRP-conjugated secondary antibody and incubate for 30-60 minutes at room temperature.

- Rinse slides with wash buffer (3 changes, 5 minutes each).
- Apply the DAB solution and incubate for 2-10 minutes, monitoring for color development under a microscope.
- Rinse slides with deionized water to stop the reaction.

5. Counterstaining and Mounting:

- Counterstain with hematoxylin for 1-2 minutes.
- "Blue" the slides in running tap water.
- Dehydrate the slides through graded alcohols (70%, 95%, 100%) and clear in xylene.
- Mount with a permanent mounting medium.

Protocol 2: Quantitative Analysis of Ki-67 using QuPath Software

This protocol outlines the workflow for digital image analysis of Ki-67 stained slides using the open-source software, QuPath.

1. Image Import and Project Creation:

- Launch QuPath and create a new project.
- Import the scanned whole-slide images of Ki-67 stained tissues into the project.

2. Annotation of Tumor Regions:

- Open an image from the project.
- Use the annotation tools (e.g., polygon, brush) to delineate the invasive tumor areas. Exclude areas of in-situ carcinoma, normal tissue, and artifacts.

3. Cell Detection:

- Select the annotated tumor region.
- Navigate to Analyze > Cell detection > Cell detection.
- Adjust the cell detection parameters (e.g., nucleus size, intensity thresholds) to accurately identify individual cell nuclei. The software provides a real-time preview to aid in optimization.

4. Positive Cell Detection (Classification):

- With the cells detected, go to Analyze > Cell detection > Positive cell detection.
- Set the scoring parameters based on the DAB stain intensity. Adjust the threshold for positive (brown) and negative (blue) nuclei.
- QuPath will classify each detected cell as positive or negative for Ki-67.

5. Data Export and Analysis:

- The Ki-67 labeling index (percentage of positive cells) is automatically calculated and displayed for the annotated region.
- Results can be exported for further statistical analysis. For hotspot analysis, smaller, densely populated positive regions can be specifically annotated and analyzed.

Visualizations

Regulation of Ki-67 Expression during the Cell Cycle

The expression of the MKI67 gene, which encodes the Ki-67 protein, is tightly regulated throughout the cell cycle. This regulation involves a complex interplay of transcription factors and repressive complexes.

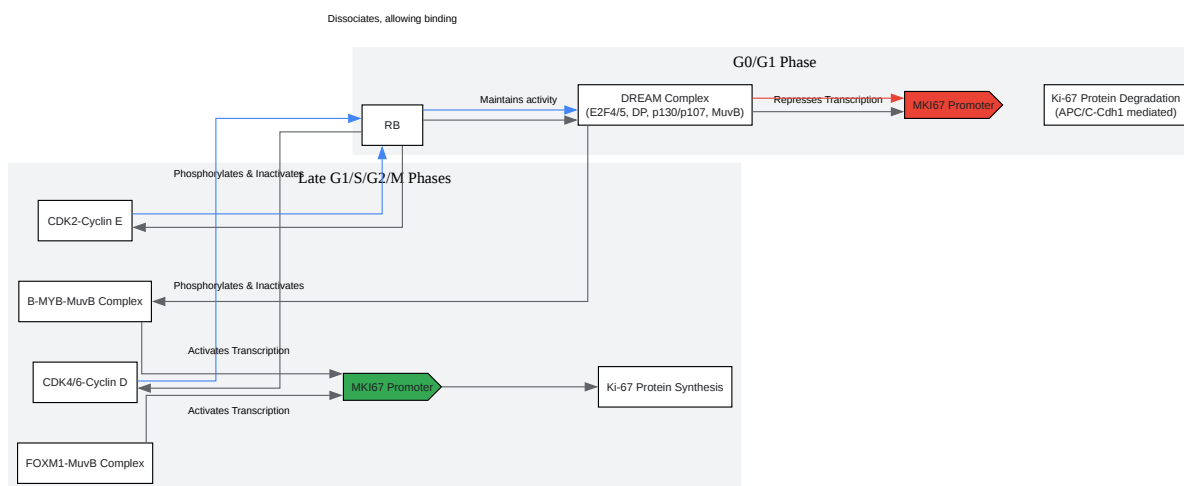

[Click to download full resolution via product page](#)

Caption: Regulation of MKI67 gene expression through the cell cycle.

Experimental Workflow for Quantitative Ki-67 Analysis

The process of quantifying Ki-67 expression involves several key steps, from tissue processing to data analysis.

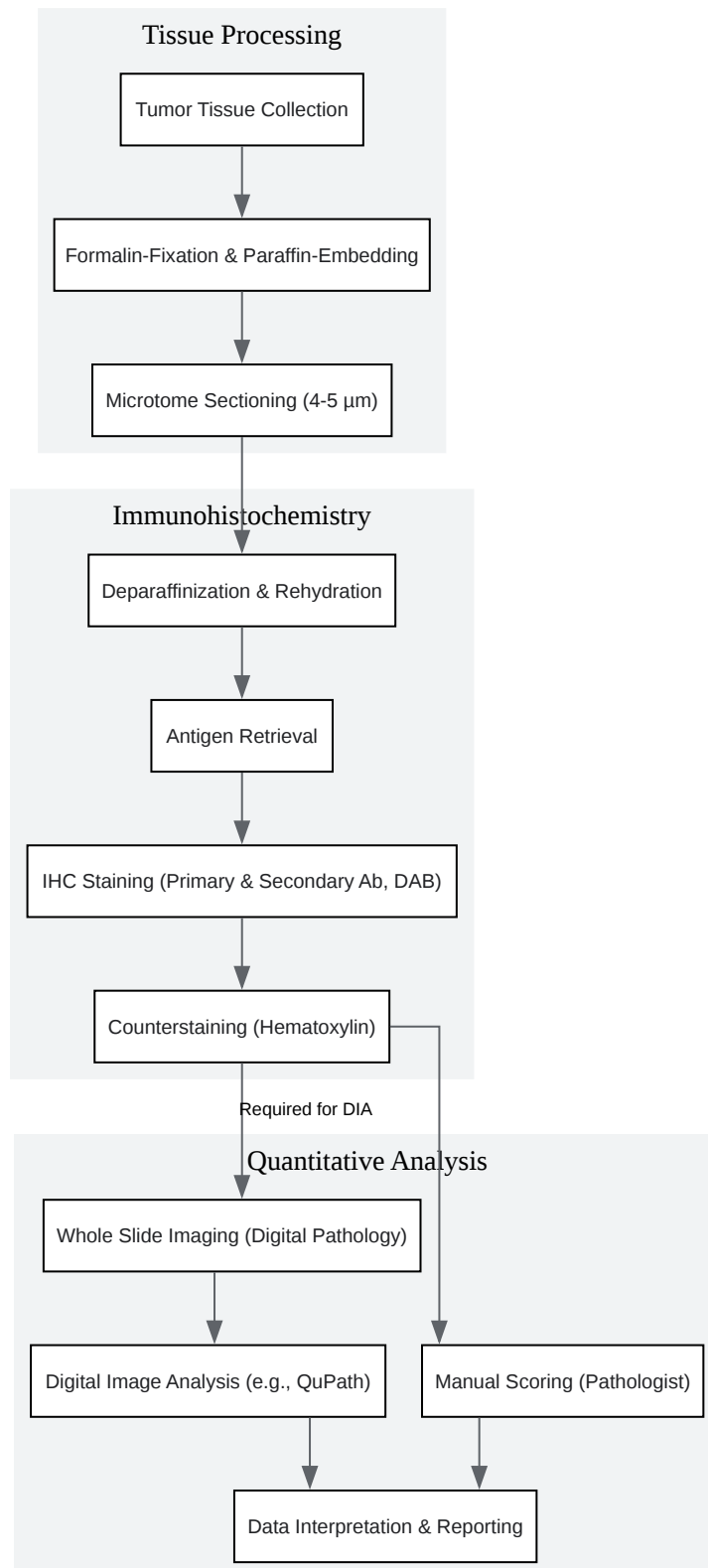

[Click to download full resolution via product page](#)

Caption: Experimental workflow for quantitative Ki-67 analysis.

Conclusion

The quantitative analysis of Ki-67 expression is a cornerstone of modern oncologic pathology. While manual assessment has been the traditional approach, digital image analysis is emerging as a more reproducible and standardized method. The protocols and data presented here provide a comprehensive guide for researchers and clinicians to accurately quantify Ki-67, thereby enhancing its prognostic and predictive power in cancer management. Careful adherence to standardized protocols is essential for obtaining reliable and clinically meaningful results.

Need Custom Synthesis?

BenchChem offers custom synthesis for rare earth carbides and specific isotopic labeling.

Email: info@benchchem.com or [Request Quote Online](#).

References

- [1. Interobserver Variability of Ki-67 Measurement in Breast Cancer \[jpatholm.org\]](#)
- [2. Ki-67 as a Prognostic Biomarker in Invasive Breast Cancer - PMC \[pmc.ncbi.nlm.nih.gov\]](#)
- [3. njlm.net \[njlm.net\]](#)
- [4. Interobserver Variability of Ki-67 Measurement in Breast Cancer - PMC \[pmc.ncbi.nlm.nih.gov\]](#)
- [5. Comparison Between Manual and Automated Assessment of Ki-67 in Breast Carcinoma: Test of a Simple Method in Daily Practice - PMC \[pmc.ncbi.nlm.nih.gov\]](#)
- [6. meddocsonline.org \[meddocsonline.org\]](#)
- [7. researchgate.net \[researchgate.net\]](#)
- [8. Prognostic value of Ki67 expression in HR-negative breast cancer before and after neoadjuvant chemotherapy - PMC \[pmc.ncbi.nlm.nih.gov\]](#)
- [9. Prognostic value of Ki-67 for prostate cancer death in a conservatively managed cohort - PMC \[pmc.ncbi.nlm.nih.gov\]](#)
- [To cite this document: BenchChem. \[Quantitative Analysis of Ki-67 Expression in Tumors: Application Notes and Protocols\]. BenchChem, \[2026\]. \[Online PDF\]. Available at: \[https://www.benchchem.com/product/b15606711/docs#quantitative-analysis-of-ki-67-expression-in-tumors-application-notes-and-protocols\]](#)

Disclaimer & Data Validity:

The information provided in this document is for Research Use Only (RUO) and is strictly not intended for diagnostic or therapeutic procedures. While BenchChem strives to provide accurate protocols, we make no warranties, express or implied, regarding the fitness of this product for every specific experimental setup.

Technical Support: The protocols provided are for reference purposes. Unsure if this reagent suits your experiment?

Need Industrial/Bulk Grade? [Request Custom Synthesis Quote](#)

BenchChem

Our mission is to be the trusted global source of essential and advanced chemicals, empowering scientists and researchers to drive progress in science and industry.

Contact

Address: 3281 E Guasti Rd

Ontario, CA 91761, United States

Phone: (601) 213-4426

Email: info@benchchem.com

[Contact our Ph.D. Support Team for a compatibility check](#)