

# Navigating Inconsistent CD73-IN-3 Experimental Data: A Technical Support Guide

**Author:** BenchChem Technical Support Team. **Date:** April 2026

## Compound of Interest

Compound Name: CD73-IN-3

Cat. No.: B15606665

[Get Quote](#)

For Researchers, Scientists, and Drug Development Professionals

This technical support center provides troubleshooting guidance and frequently asked questions (FAQs) to address common challenges encountered when working with the CD73 inhibitor, **CD73-IN-3**. Our aim is to help you achieve more consistent and reliable experimental outcomes.

## Frequently Asked Questions (FAQs)

Q1: What is the mechanism of action for **CD73-IN-3**?

A1: **CD73-IN-3** is a potent inhibitor of CD73, also known as ecto-5'-nucleotidase. CD73 is a cell-surface enzyme that plays a critical role in the adenosine signaling pathway by converting adenosine monophosphate (AMP) to adenosine.<sup>[1]</sup> Adenosine, in turn, acts as an immunosuppressive molecule within the tumor microenvironment, helping cancer cells evade the immune system.<sup>[1]</sup> By blocking CD73, **CD73-IN-3** reduces the production of immunosuppressive adenosine, which can enhance the anti-tumor immune response.<sup>[1]</sup>

Q2: What are the recommended storage and handling conditions for **CD73-IN-3**?

A2: Proper storage and handling are crucial for maintaining the stability and activity of **CD73-IN-3**.

- Powder: Store at -20°C for up to 3 years or at 4°C for up to 2 years.
- In solvent: Prepare stock solutions in a suitable solvent like DMSO. Store at -80°C for up to 6 months or at -20°C for up to 1 month. Avoid repeated freeze-thaw cycles.

Q3: What is the solubility of **CD73-IN-3**?

A3: **CD73-IN-3** has the following solubility profile:

- DMSO: Soluble up to 100 mg/mL (349.25 mM). Ultrasonic treatment may be needed to fully dissolve the compound. Note that DMSO is hygroscopic and can impact solubility.
- In vivo formulations:
  - A clear solution of at least 2.5 mg/mL (8.73 mM) can be achieved in a formulation of 10% DMSO and 90% (20% SBE- $\beta$ -CD in Saline).
  - A clear solution of at least 2.5 mg/mL (8.73 mM) can also be prepared in 10% DMSO and 90% Corn Oil.

If you observe precipitation during preparation, gentle heating and/or sonication can aid in dissolution.

## Troubleshooting Inconsistent Experimental Data

### Scenario 1: Observed IC50 Value for **CD73-IN-3** is Higher Than Expected

You perform a cell-based assay to determine the potency of **CD73-IN-3** and find that the half-maximal inhibitory concentration (IC50) is significantly higher than the reported value of 7.3 nM in Calu6 cells.

Potential Cause	Explanation	Suggested Solution
Cellular ATP Concentration	Biochemical assays are often conducted at ATP concentrations close to the Michaelis constant ( $K_m$ ) of the target enzyme. However, intracellular ATP levels are typically much higher. For ATP-competitive inhibitors, this increased competition in a cellular environment can lead to a higher apparent $IC_{50}$ .	Acknowledge the potential for a shift in potency between biochemical and cellular assays. Consider using cell lines with varying endogenous ATP levels to assess the impact on inhibitor potency.
Cell Permeability	CD73-IN-3 may have poor permeability across the cell membrane, leading to a lower effective intracellular concentration compared to the concentration applied externally.	Evaluate the cell permeability of CD73-IN-3 using standard assays (e.g., PAMPA). If permeability is low, consider using cell lines with higher expression of relevant transporters or using permeabilizing agents (with appropriate controls).
Presence of Soluble CD73	Many cell types can shed a soluble form of CD73 (sCD73) into the culture medium. This sCD73 can also be present in serum used for cell culture. <sup>[2]</sup> <sup>[3]</sup> sCD73 can bind to the inhibitor, reducing the effective concentration available to inhibit cell-surface CD73.	Measure sCD73 levels in your cell culture supernatant and serum using an ELISA or activity assay. Consider using serum-free media or heat-inactivated serum to reduce the impact of sCD73 and other serum proteins.
Inhibitor Stability and Degradation	The inhibitor may be metabolized by cellular enzymes or be unstable in the cell culture medium over the course of the experiment,	Assess the stability of CD73-IN-3 in your specific cell culture medium over time using methods like HPLC. If degradation is observed,

leading to a decrease in the active concentration.

consider shorter incubation times or replenishing the inhibitor during the experiment.

---

#### Efflux Pump Activity

Cells can actively transport the inhibitor out of the cell using efflux pumps like P-glycoprotein, which reduces the intracellular concentration of the inhibitor.

Use efflux pump inhibitors (e.g., verapamil) as a tool to determine if efflux is contributing to the higher IC50. Be aware of potential off-target effects of the efflux pump inhibitor itself.

---

## Scenario 2: High Variability Between Replicate Wells in an In Vitro CD73 Activity Assay

You are performing a biochemical assay to measure the enzymatic activity of recombinant CD73 in the presence of **CD73-IN-3**, but you observe significant variability between your replicate wells, making it difficult to obtain a reliable dose-response curve.

Potential Cause	Explanation	Suggested Solution
Inhibitor Precipitation	Small molecule inhibitors can sometimes precipitate out of solution, especially at higher concentrations, leading to inconsistent concentrations in the assay wells.	<p>Visually inspect your inhibitor stock and working solutions for any signs of precipitation.</p> <p>Determine the critical aggregation concentration (CAC) of CD73-IN-3 in your assay buffer. Consider adding a small amount of a non-ionic detergent like Triton X-100 (e.g., 0.01%) to your assay buffer to help prevent aggregation.</p>
Pipetting Errors	Inaccurate or inconsistent pipetting of the inhibitor, enzyme, or substrate can lead to significant well-to-well variability.	Ensure your pipettes are properly calibrated. Use reverse pipetting for viscous solutions. Mix all reagents thoroughly before dispensing into the assay plate.
Assay Edge Effects	Evaporation from the outer wells of a microplate can concentrate the reagents and lead to higher or lower enzyme activity compared to the inner wells.	Avoid using the outer wells of the plate for your experimental samples. Fill the outer wells with buffer or water to minimize evaporation from the inner wells. Ensure proper sealing of the plate during incubation.
Inconsistent Incubation Time or Temperature	Variations in incubation time or temperature across the assay plate can affect the rate of the enzymatic reaction.	<p>Use a high-quality incubator that provides uniform temperature distribution.</p> <p>Ensure that the time between adding the start reagent and the stop reagent is consistent for all wells.</p>

## Quantitative Data Summary

Parameter	Value	Assay Conditions	Reference
IC50	7.3 nM	Calu6 human cell assay	[MedchemExpress]
EC50	0.213 $\mu$ M	Human serum	[MedchemExpress]
Inhibition in Human Serum	56.8% at 0.52 $\mu$ M	Human serum	[MedchemExpress]
Inhibition in Human Serum	71.7% at 1.56 $\mu$ M	Human serum	[MedchemExpress]
Inhibition in Human Serum	76.9% at 4.68 $\mu$ M	Human serum	[MedchemExpress]

## Experimental Protocols

### Protocol 1: In Vitro CD73 Enzymatic Activity Assay (Malachite Green Assay)

This protocol is adapted from commercially available kits and measures the inorganic phosphate (Pi) released from the hydrolysis of AMP by CD73.

Materials:

- Recombinant human CD73
- **CD73-IN-3**
- AMP (substrate)
- Malachite Green Reagent
- Phosphate Standard
- Assay Buffer (e.g., Tris-based buffer, pH 7.4)

- 96-well microplate

Procedure:

- Prepare Reagents:
  - Prepare a series of dilutions of **CD73-IN-3** in assay buffer.
  - Prepare a solution of recombinant CD73 in assay buffer.
  - Prepare a solution of AMP in assay buffer.
  - Prepare a phosphate standard curve according to the manufacturer's instructions.
- Assay Setup:
  - Add 20  $\mu$ L of each **CD73-IN-3** dilution to the appropriate wells of the 96-well plate. Include a vehicle control (e.g., DMSO).
  - Add 20  $\mu$ L of the CD73 enzyme solution to all wells except the "no enzyme" control wells. Add 20  $\mu$ L of assay buffer to the "no enzyme" control wells.
  - Pre-incubate the plate at 37°C for 10-15 minutes.
- Initiate Reaction:
  - Add 10  $\mu$ L of the AMP substrate solution to all wells to start the reaction.
  - Incubate the plate at 37°C for a predetermined time (e.g., 20-30 minutes). The incubation time may need to be optimized based on the enzyme activity.
- Stop Reaction and Detection:
  - Stop the reaction by adding 50  $\mu$ L of the Malachite Green Reagent to each well.
  - Incubate at room temperature for 15-20 minutes to allow for color development.
- Data Analysis:

- Measure the absorbance at 620-640 nm using a microplate reader.
- Subtract the absorbance of the "no enzyme" control from all other readings.
- Use the phosphate standard curve to determine the amount of Pi produced in each well.
- Calculate the percent inhibition for each concentration of **CD73-IN-3** and determine the IC50 value by fitting the data to a dose-response curve.

## Protocol 2: Cell-Based CD73 Activity Assay

This protocol measures the activity of cell-surface CD73.

Materials:

- Cancer cell line expressing CD73 (e.g., Calu6)
- **CD73-IN-3**
- AMP (substrate)
- Adenosine detection kit (e.g., luminescence-based)
- Cell culture medium
- 96-well cell culture plate

Procedure:

- Cell Seeding:
  - Seed the CD73-expressing cells in a 96-well plate at a predetermined density and allow them to adhere overnight.
- Inhibitor Treatment:
  - Prepare a series of dilutions of **CD73-IN-3** in cell culture medium.

- Remove the old medium from the cells and add 100  $\mu$ L of the **CD73-IN-3** dilutions to the appropriate wells. Include a vehicle control.
- Pre-incubate the cells with the inhibitor for a specified time (e.g., 1-2 hours) at 37°C.
- Enzymatic Reaction:
  - Add AMP substrate to each well to a final concentration that is appropriate for the assay.
  - Incubate the plate at 37°C for a time that allows for measurable adenosine production without substrate depletion.
- Adenosine Detection:
  - Following the incubation, take an aliquot of the supernatant from each well.
  - Measure the adenosine concentration in the supernatant using an adenosine detection kit according to the manufacturer's protocol.
- Data Analysis:
  - Calculate the percent inhibition of adenosine production for each concentration of **CD73-IN-3**.
  - Determine the IC50 value by fitting the data to a dose-response curve.

## Visualizations

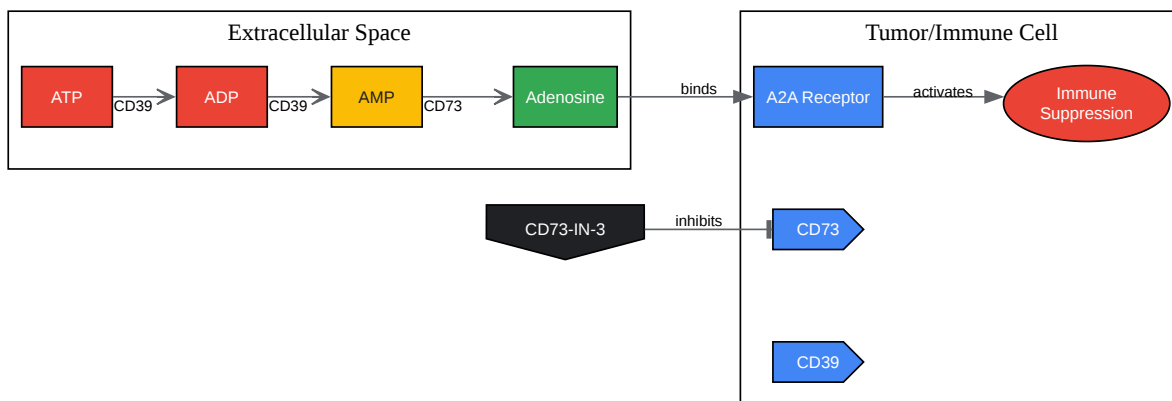

[Click to download full resolution via product page](#)

Caption: CD73 Signaling Pathway and Inhibition by **CD73-IN-3**.

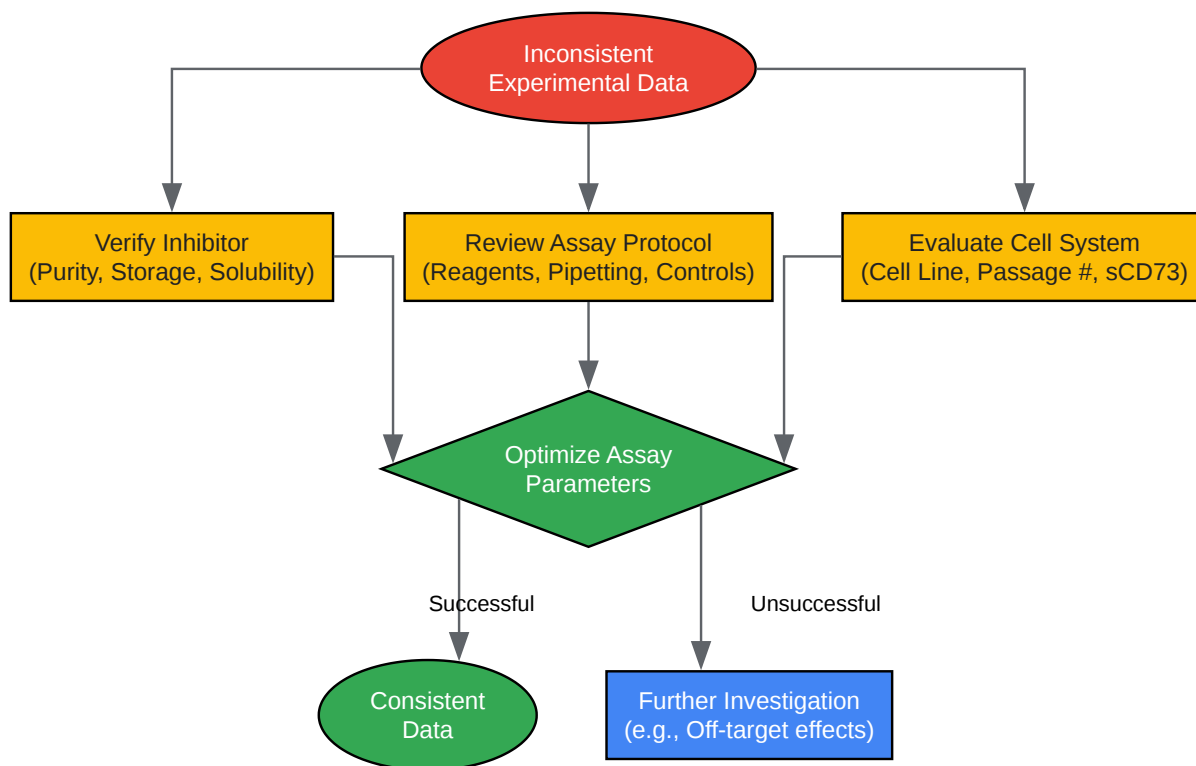

[Click to download full resolution via product page](#)

Caption: Troubleshooting Workflow for Inconsistent **CD73-IN-3** Data.

### Need Custom Synthesis?

BenchChem offers custom synthesis for rare earth carbides and specific isotopic labeling.

Email: [info@benchchem.com](mailto:info@benchchem.com) or [Request Quote Online](#).

## References

- [1. Frontiers | CD39 and CD73 as Promising Therapeutic Targets: What Could Be the Limitations? \[frontiersin.org\]](#)
- [2. Serum CD73 is a prognostic factor in patients with metastatic melanoma and is associated with response to anti-PD-1 therapy - PMC \[pmc.ncbi.nlm.nih.gov\]](#)
- [3. mdpi.com \[mdpi.com\]](#)
- To cite this document: BenchChem. [Navigating Inconsistent CD73-IN-3 Experimental Data: A Technical Support Guide]. BenchChem, [2026]. [Online PDF]. Available at: [\[https://www.benchchem.com/product/b15606665/docs#navigating-inconsistent-cd73-in-3-experimental-data-a-technical-support-guide\]](https://www.benchchem.com/product/b15606665/docs#navigating-inconsistent-cd73-in-3-experimental-data-a-technical-support-guide)

---

### Disclaimer & Data Validity:

The information provided in this document is for Research Use Only (RUO) and is strictly not intended for diagnostic or therapeutic procedures. While BenchChem strives to provide accurate protocols, we make no warranties, express or implied, regarding the fitness of this product for every specific experimental setup.

**Technical Support:** The protocols provided are for reference purposes. Unsure if this reagent suits your experiment?

**Need Industrial/Bulk Grade?** [Request Custom Synthesis Quote](#)

# BenchChem

Our mission is to be the trusted global source of essential and advanced chemicals, empowering scientists and researchers to drive progress in science and industry.

## Contact

Address: 3281 E Guasti Rd

Ontario, CA 91761, United States

Phone: (601) 213-4426

Email: [info@benchchem.com](mailto:info@benchchem.com)

[Contact our Ph.D. Support Team for a compatibility check](#)