

LP-471756 as a Negative Control in GPR139 Studies: A Comparative Guide

Author: BenchChem Technical Support Team. **Date:** April 2026

Compound of Interest

Compound Name: LP-471756

Cat. No.: B15606455

Get Quote

For Researchers, Scientists, and Drug Development Professionals

This guide provides a comprehensive comparison of **LP-471756** with other available antagonists for the G protein-coupled receptor 139 (GPR139), offering a data-driven perspective on its use as a negative control in research settings. GPR139 is an orphan receptor predominantly expressed in the central nervous system, implicated in various physiological processes, making pharmacological tools to dissect its function crucial.^[1]

Performance Comparison of GPR139 Antagonists

LP-471756 is a known antagonist of GPR139.^{[2][3]} Its utility as a negative control is best assessed by comparing its potency and activity with other known inhibitors of the receptor. The following table summarizes the available quantitative data for **LP-471756** and alternative GPR139 antagonists. It is important to note that the experimental conditions, such as the agonist, its concentration, and the cell line used, vary between studies, which can influence the measured IC₅₀ values.

Compound	Antagonist Activity (IC50)	Assay Type	Agonist Used	Cell Line	Reference
LP-471756	640 nM	cAMP Production	LP-360924	GPR139-expressing cells	[2]
LP-114958	0.67 μ M	Not Specified	Not Specified	Not Specified	[4]
NCRW0001-C02	0.42 μ M	Not Specified	Not Specified	CHO-K1	[4]
0.513 μ M	Not Specified	Not Specified	CHO-T-Rex	[4]	
NCRW0005-F05	0.21 μ M	Not Specified	Not Specified	CHO-K1	[4]
147.9 nM	Dual-luciferase reporter	JNJ-63533054 (30 nM)	Zebrafish GPR139	[5][6]	
NCRW0008-C04	2.1 μ M	Not Specified	Not Specified	Not Specified	[4]
NCRW0095-F03	0.83 μ M	Not Specified	Not Specified	Not Specified	[4]
NCRW0105-E06	0.43 μ M	Not Specified	Not Specified	Not Specified	[4]

GPR139 Signaling Pathways

GPR139 is known to couple to multiple G protein signaling pathways, with the Gq/11 pathway being primary.[1][7] Activation of GPR139 by agonists such as L-tryptophan, L-phenylalanine, or synthetic compounds like JNJ-63533054 can lead to downstream cellular responses through various G proteins.[8][9] Understanding these pathways is essential for designing and interpreting experiments using antagonists like **LP-471756**.

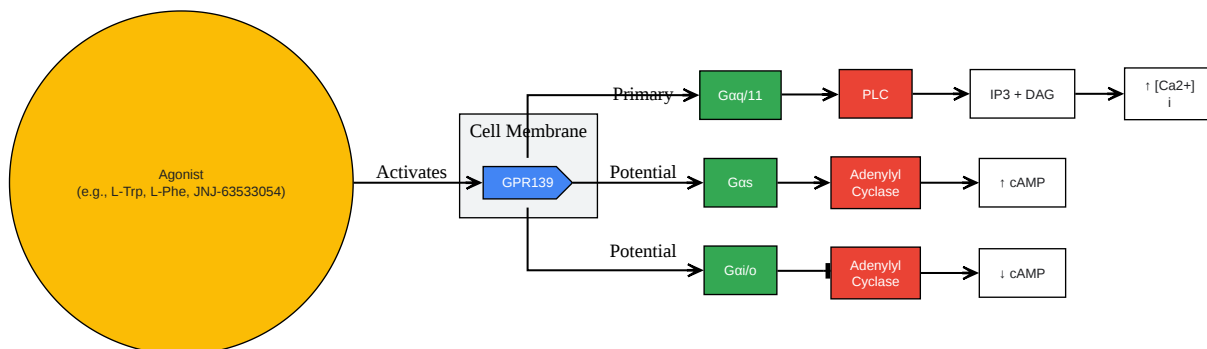

[Click to download full resolution via product page](#)

Caption: GPR139 Signaling Pathways.

Experimental Protocols

Detailed methodologies for key assays used to characterize GPR139 antagonists are provided below. These protocols are generalized from multiple sources and may require optimization for specific cell lines and experimental conditions.

Calcium Mobilization Assay

This assay is a common method for assessing Gq/11-coupled GPCR activity by measuring changes in intracellular calcium concentration upon receptor activation.^{[10][11][12]}

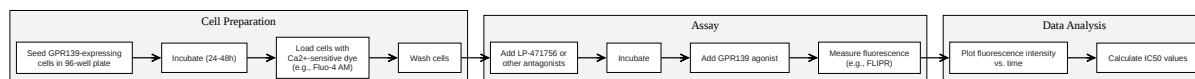

[Click to download full resolution via product page](#)

Caption: Calcium Mobilization Assay Workflow.

Detailed Steps:

- Cell Culture: Plate cells stably or transiently expressing GPR139 in a 96-well or 384-well black, clear-bottom plate and culture for 24-48 hours.
- Dye Loading: Remove the culture medium and load the cells with a calcium-sensitive fluorescent dye (e.g., Fluo-4 AM) in a suitable buffer for 30-60 minutes at 37°C.
- Washing: Gently wash the cells to remove excess dye.
- Antagonist Addition: Add varying concentrations of the antagonist (e.g., **LP-471756**) to the wells and incubate for a predetermined time.
- Agonist Stimulation: Add a GPR139 agonist at a fixed concentration (typically EC50 or EC80) to stimulate the receptor.
- Fluorescence Measurement: Immediately measure the change in fluorescence intensity over time using a fluorescence plate reader (e.g., FLIPR or FlexStation).
- Data Analysis: Determine the inhibitory effect of the antagonist by plotting the agonist-induced fluorescence signal against the antagonist concentration to calculate the IC50 value.

cAMP Production Assay

This assay measures the modulation of intracellular cyclic adenosine monophosphate (cAMP) levels, which is useful for studying Gs or Gi/o-coupled receptor activity.^{[13][14][15]}

Detailed Steps:

- Cell Culture: Culture GPR139-expressing cells in a suitable multi-well plate.
- Pre-incubation: Pre-incubate the cells with varying concentrations of the antagonist (e.g., **LP-471756**) in the presence of a phosphodiesterase inhibitor (e.g., IBMX) to prevent cAMP degradation.

- **Agonist Stimulation:** Add a GPR139 agonist to stimulate Gs-mediated cAMP production or an adenylyl cyclase activator (e.g., forskolin) followed by an agonist to measure Gi-mediated inhibition of cAMP production.
- **Cell Lysis:** Lyse the cells to release intracellular cAMP.
- **cAMP Detection:** Measure the cAMP concentration using a competitive immunoassay, such as HTRF, AlphaScreen, or ELISA-based kits.
- **Data Analysis:** Plot the measured cAMP levels against the antagonist concentration to determine the IC50 value.

GTPyS Binding Assay

This functional membrane-based assay measures the initial step of G protein activation—the exchange of GDP for GTP on the G α subunit.[\[16\]](#)[\[17\]](#)[\[18\]](#)[\[19\]](#)

Detailed Steps:

- **Membrane Preparation:** Prepare cell membranes from cells overexpressing GPR139.
- **Assay Setup:** In a multi-well plate, combine the cell membranes, varying concentrations of the antagonist, a fixed concentration of the agonist, and a non-hydrolyzable GTP analog, [³⁵S]GTPyS.
- **Incubation:** Incubate the mixture to allow for agonist-stimulated [³⁵S]GTPyS binding to the G proteins.
- **Separation:** Separate the membrane-bound [³⁵S]GTPyS from the unbound nucleotide, typically by rapid filtration.
- **Scintillation Counting:** Measure the amount of bound [³⁵S]GTPyS using a scintillation counter.
- **Data Analysis:** Determine the inhibitory effect of the antagonist by plotting the amount of [³⁵S]GTPyS bound against the antagonist concentration to calculate the IC50 value.

By utilizing **LP-471756** as a negative control and comparing its effects to other known antagonists within these well-defined experimental frameworks, researchers can confidently probe the function and signaling of GPR139.

Need Custom Synthesis?

BenchChem offers custom synthesis for rare earth carbides and specific isotopic labeling.

Email: info@benchchem.com or [Request Quote Online](#).

References

- [1. Pharmacology and function of the orphan GPR139 G protein-coupled receptor - PMC \[pmc.ncbi.nlm.nih.gov\]](#)
- [2. medchemexpress.com \[medchemexpress.com\]](#)
- [3. medchemexpress.com \[medchemexpress.com\]](#)
- [4. GPR139, an Ancient Receptor and an Emerging Target for Neuropsychiatric and Behavioral Disorders - PMC \[pmc.ncbi.nlm.nih.gov\]](#)
- [5. GPR139 agonist and antagonist differentially regulate retrieval and consolidation of fear memory in the zebrafish - PMC \[pmc.ncbi.nlm.nih.gov\]](#)
- [6. frontiersin.org \[frontiersin.org\]](#)
- [7. The orphan receptor GPR139 signals via Gq/11 to oppose opioid effects - PubMed \[pubmed.ncbi.nlm.nih.gov\]](#)
- [8. Identification of surrogate agonists and antagonists for orphan G-protein-coupled receptor GPR139 - PubMed \[pubmed.ncbi.nlm.nih.gov\]](#)
- [9. The orphan receptor GPR139 signals via Gq/11 to oppose opioid effects - PMC \[pmc.ncbi.nlm.nih.gov\]](#)
- [10. Characterization of G Protein-coupled Receptors by a Fluorescence-based Calcium Mobilization Assay - PMC \[pmc.ncbi.nlm.nih.gov\]](#)
- [11. Ca²⁺ mobilization assays in GPCR drug discovery - PubMed \[pubmed.ncbi.nlm.nih.gov\]](#)
- [12. Ca²⁺ Mobilization Assay - Creative Bioarray \[dda.creative-bioarray.com\]](#)
- [13. 4 Guides to Optimize your Gas and Gai GPCR assays | Technology Networks \[technologynetworks.com\]](#)
- [14. resources.revvity.com \[resources.revvity.com\]](#)

- [15. cAMP-Glo™ Assay Protocol \[worldwide.promega.com\]](#)
- [16. GTPyS Binding Assay - Creative Bioarray \[dda.creative-bioarray.com\]](#)
- [17. GTPyS Binding Assays - Assay Guidance Manual - NCBI Bookshelf \[ncbi.nlm.nih.gov\]](#)
- [18. resources.revvity.com \[resources.revvity.com\]](#)
- [19. Use of the GTPyS \(\[35S\]GTPyS and Eu-GTPyS\) binding assay for analysis of ligand potency and efficacy at G protein-coupled receptors - PMC \[pmc.ncbi.nlm.nih.gov\]](#)
- To cite this document: BenchChem. [LP-471756 as a Negative Control in GPR139 Studies: A Comparative Guide]. BenchChem, [2026]. [Online PDF]. Available at: [\[https://www.benchchem.com/product/b15606455/docs#lp-471756-as-a-negative-control-in-gpr139-studies-a-comparative-guide\]](https://www.benchchem.com/product/b15606455/docs#lp-471756-as-a-negative-control-in-gpr139-studies-a-comparative-guide)

Disclaimer & Data Validity:

The information provided in this document is for Research Use Only (RUO) and is strictly not intended for diagnostic or therapeutic procedures. While BenchChem strives to provide accurate protocols, we make no warranties, express or implied, regarding the fitness of this product for every specific experimental setup.

Technical Support: The protocols provided are for reference purposes. Unsure if this reagent suits your experiment?

Need Industrial/Bulk Grade? [Request Custom Synthesis Quote](#)

BenchChem

Our mission is to be the trusted global source of essential and advanced chemicals, empowering scientists and researchers to drive progress in science and industry.

Contact

Address: 3281 E Guasti Rd
Ontario, CA 91761, United States
Phone: (601) 213-4426
Email: info@benchchem.com

Contact our Ph.D. Support Team for a compatibility check