

# Interpreting unexpected results with ITX3

**Author:** BenchChem Technical Support Team. **Date:** April 2026

## Compound of Interest

Compound Name: ITX3  
Cat. No.: B15606329

[Get Quote](#)

## ITX3 Technical Support Center

Welcome to the technical support center for **ITX3**, a selective inhibitor of the TrioN RhoGEF domain. This resource is designed to help you interpret unexpected results and troubleshoot common issues you may encounter during your experiments.

## Frequently Asked Questions (FAQs)

Q1: What is the primary mechanism of action for **ITX3**?

A1: **ITX3** is a cell-permeable small molecule that selectively inhibits the N-terminal guanine nucleotide exchange factor (GEF) domain of Trio (TrioN).[1][2] By inhibiting TrioN, **ITX3** blocks the exchange of GDP for GTP on the small GTPases RhoG and Rac1, thereby preventing their activation.[1][2][3] This leads to the downstream inhibition of cellular processes such as membrane ruffling, neurite outgrowth, and cell migration.[1][4]

Q2: I'm observing a weaker-than-expected inhibitory effect of **ITX3** on Rac1 activation. What could be the cause?

A2: A weaker-than-expected effect could be due to several factors:

- **Suboptimal Concentration:** Ensure you are using **ITX3** at a concentration sufficient to inhibit TrioN. The reported IC50 is 76  $\mu$ M in biochemical assays, but higher concentrations (e.g., 50-100  $\mu$ M) may be necessary for robust inhibition in cell-based assays.[2]
- **Alternative GEFs:** The cells you are using may have redundant or alternative GEFs that can activate Rac1 independently of TrioN.[5] Consider investigating the expression levels of other Rac1 GEFs like Tiam1 or Vav2 in your cell line.
- **Compound Stability:** Ensure the **ITX3** stock solution has been stored correctly and has not undergone multiple freeze-thaw cycles. We recommend storing stock solutions at -20°C or -80°C.

Q3: I'm seeing significant cell death at concentrations where I expect to see specific inhibition. Is this normal?

A3: While **ITX3** is reported to be non-toxic, high concentrations of any small molecule inhibitor can lead to off-target effects and cytotoxicity.[2][6] We recommend performing a dose-response curve to determine the optimal concentration that inhibits TrioN activity without causing significant cell death. If you observe toxicity at concentrations close to the effective dose, consider the following:

- **Off-Target Effects:** At high concentrations, **ITX3** might be inhibiting other essential cellular targets.[7][8]
- **Cell Line Sensitivity:** Your specific cell line may be particularly sensitive to the inhibition of the Trio/Rac1 signaling pathway or to the compound itself.

Q4: Can **ITX3** affect RhoA signaling?

A4: **ITX3** is selective for the TrioN GEF domain, which activates RhoG and Rac1. The second GEF domain of Trio (TrioC) activates RhoA.[3][5] **ITX3** has been shown to have no effect on RhoA activation mediated by other GEFs.[1] Therefore, it is not expected to directly inhibit RhoA signaling. However, complex cellular crosstalk between Rho family GTPases is possible.

## Troubleshooting Guide

### Issue 1: High Background in Rac1 Activity Assay

Symptom: The negative control (GDP-loaded) and the vehicle-treated samples in your Rac1 pull-down assay show a strong signal, making it difficult to assess the inhibitory effect of **ITX3**.

Possible Causes and Solutions:

Possible Cause	Troubleshooting Step
Incomplete Cell Lysis	Ensure complete cell lysis to release all cellular proteins. Optimize lysis buffer composition and incubation time.
Non-specific Binding to Beads	Pre-clear the lysate with agarose beads before adding the PAK1-PBD beads. Increase the number and stringency of washes after the pull-down.
Suboptimal Antibody Concentration	Titrate the primary and secondary antibody concentrations to reduce background signal.
Contaminated Reagents	Use fresh, high-quality reagents and buffers.

## Issue 2: Unexpected Increase in a Cellular Phenotype

Symptom: Instead of the expected inhibition of cell migration or invasion, treatment with **ITX3** leads to an increase in this phenotype.

Possible Causes and Solutions:

Possible Cause	Troubleshooting Step
Paradoxical Pathway Activation	Inhibition of one signaling pathway can sometimes lead to the compensatory activation of another.[8] This could be due to the disruption of a negative feedback loop.
Off-Target Activation	At certain concentrations, ITX3 could be activating an off-target protein that promotes the observed phenotype.[7]
Cellular Heterogeneity	The cell population may be heterogeneous, and a subpopulation that is resistant to or paradoxically responds to ITX3 may be selected for during the experiment.

#### Recommended Actions:

- **Validate with a Second Inhibitor:** Use a structurally different inhibitor of the Trio-Rac1 pathway to see if it recapitulates the effect.
- **Genetic Knockdown:** Use siRNA or CRISPR to knock down Trio and observe if the phenotype matches that of **ITX3** treatment.
- **Dose-Response Analysis:** Perform a detailed dose-response curve to see if the activating effect is present at all concentrations.

## Visualizing Experimental Workflows and Signaling Pathways

### Troubleshooting Workflow for Unexpected Results

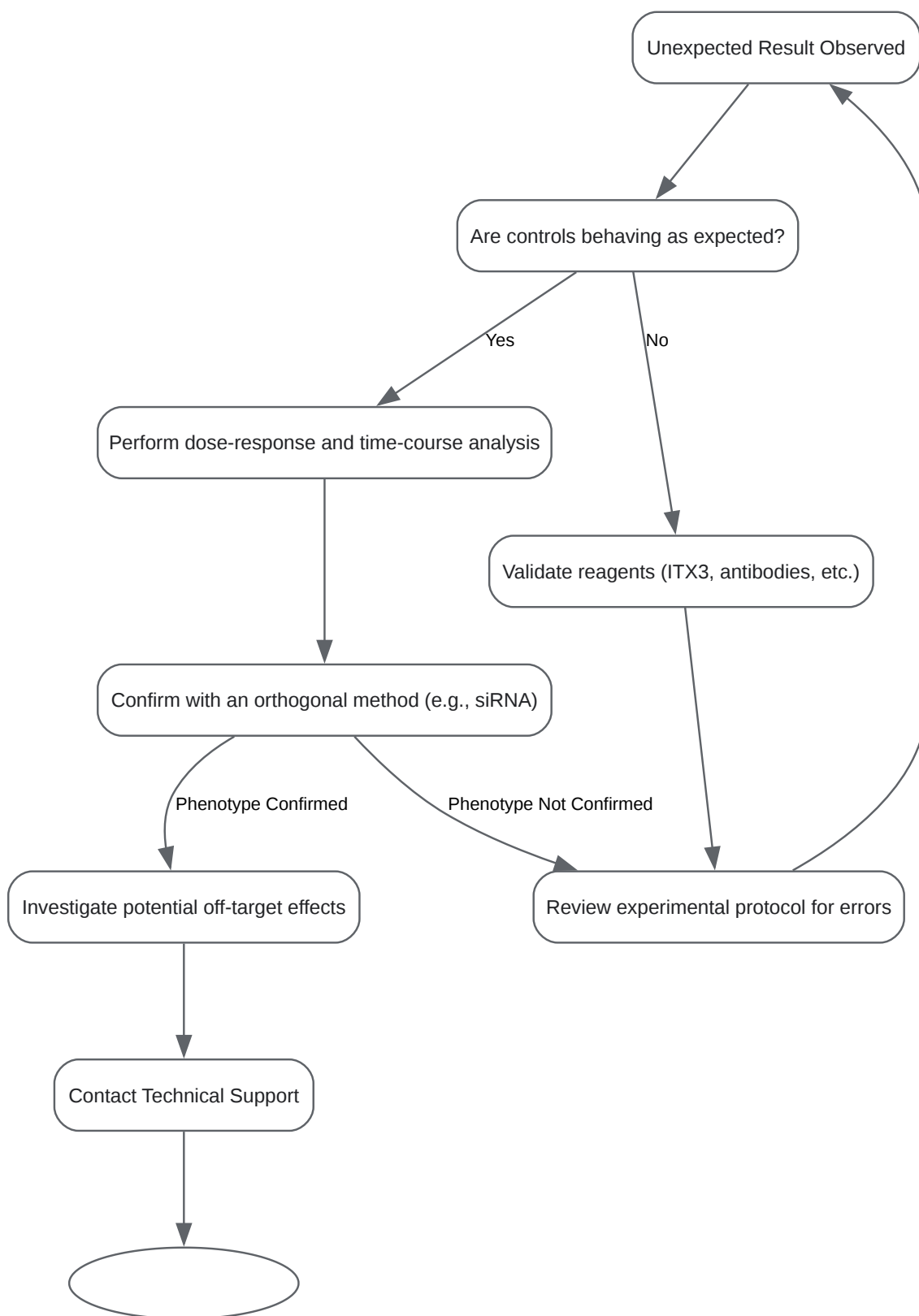

[Click to download full resolution via product page](#)

Caption: Troubleshooting workflow for interpreting unexpected experimental outcomes with ITX3.

## Hypothetical ITX3 Signaling Pathway

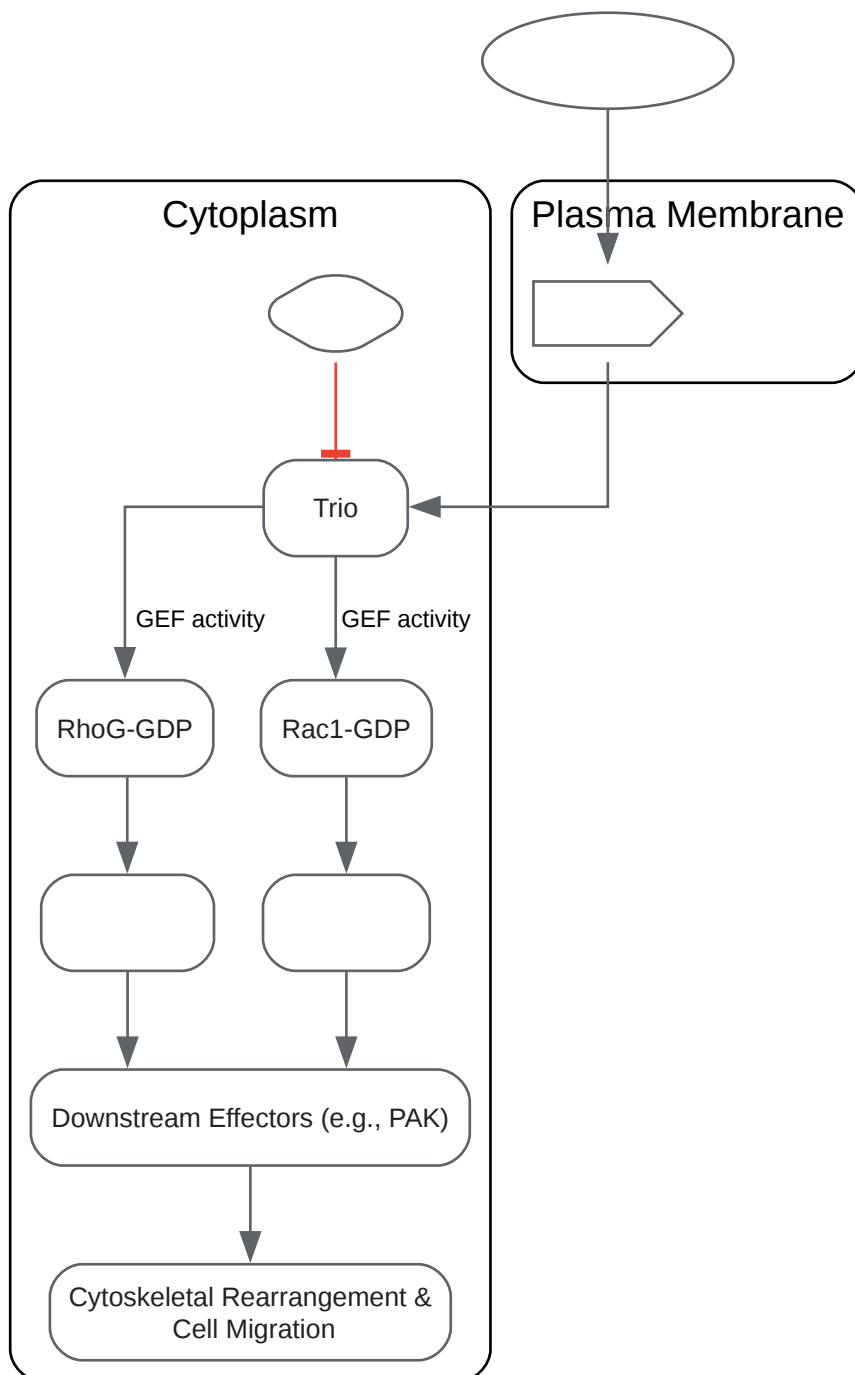

[Click to download full resolution via product page](#)

Caption: Simplified signaling pathway showing **ITX3** inhibition of Trio-mediated Rac1/RhoG activation.

## Quantitative Data Summary

The following table provides an example of expected versus unexpected results in a Rac1 activity pull-down assay following treatment with **ITX3**.

Treatment	Expected Relative Rac1-GTP Level	Example of Unexpected Result	Possible Interpretation of Unexpected Result
Vehicle Control	1.00	1.00	N/A
ITX3 (50 $\mu$ M)	0.45	0.95	Ineffective inhibition (see FAQs)
Positive Control (e.g., EGF)	3.50	3.60	Assay is working correctly
ITX3 + Positive Control	1.20	3.40	Ineffective inhibition

## Experimental Protocols

### Rac1 Activation Pull-Down Assay

This protocol is for determining the level of active, GTP-bound Rac1 in cell lysates.

Materials:

- Rac1 Activation Assay Kit (containing PAK1-PBD agarose beads)
- Cell lysis buffer
- Protease and phosphatase inhibitors
- Anti-Rac1 antibody
- Secondary antibody

- Chemiluminescent substrate

#### Methodology:

- Cell Treatment: Plate cells and grow to 70-80% confluency. Treat with **ITX3** or vehicle control for the desired time.
- Cell Lysis: Wash cells with ice-cold PBS and lyse with ice-cold lysis buffer containing protease and phosphatase inhibitors.
- Lysate Clarification: Scrape cells and centrifuge the lysate at 14,000 x g for 10 minutes at 4°C to pellet cell debris.
- Pull-Down: Incubate the clarified lysate with PAK1-PBD agarose beads for 1 hour at 4°C with gentle rotation.
- Washing: Pellet the beads by centrifugation and wash three times with wash buffer.
- Elution: Resuspend the beads in 2x SDS-PAGE sample buffer and boil for 5 minutes to elute the bound proteins.
- Western Blotting: Separate the proteins by SDS-PAGE, transfer to a PVDF membrane, and probe with an anti-Rac1 antibody.
- Detection: Visualize the bands using a chemiluminescent substrate and an imaging system.

## Cell Migration (Wound Healing) Assay

This protocol is for assessing the effect of **ITX3** on cell migration.

#### Materials:

- Culture plates or inserts for creating a cell-free gap
- Cell culture medium
- **ITX3**
- Microscope with imaging capabilities

#### Methodology:

- Cell Seeding: Seed cells in a culture plate or insert to create a confluent monolayer.
- Creating the "Wound": Create a cell-free gap by scratching the monolayer with a pipette tip or by removing the insert.
- Treatment: Wash the cells to remove debris and add fresh medium containing **ITX3** or a vehicle control.
- Image Acquisition: Capture images of the wound at time 0 and at regular intervals (e.g., every 4-6 hours) until the wound in the control wells is nearly closed.
- Data Analysis: Measure the area of the wound at each time point for all conditions. Calculate the rate of wound closure to determine the effect of **ITX3** on cell migration.

#### *Need Custom Synthesis?*

*BenchChem offers custom synthesis for rare earth carbides and specific isotopic labeling.*

*Email: [info@benchchem.com](mailto:info@benchchem.com) or [Request Quote Online](#).*

## References

- [1. A cell active chemical GEF inhibitor selectively targets the Trio/RhoG/Rac1 signaling pathway - PubMed \[pubmed.ncbi.nlm.nih.gov\]](#)
- [2. medchemexpress.com \[medchemexpress.com\]](#)
- [3. The RhoGEF Trio: A Protein with a Wide Range of Functions in the Vascular Endothelium - PMC \[pmc.ncbi.nlm.nih.gov\]](#)
- [4. Function and regulation of the Rho guanine nucleotide exchange factor Trio - PMC \[pmc.ncbi.nlm.nih.gov\]](#)
- [5. The two guanine nucleotide exchange factor domains of Trio link the Rac1 and the RhoA pathways in vivo - PubMed \[pubmed.ncbi.nlm.nih.gov\]](#)
- [6. benchchem.com \[benchchem.com\]](#)
- [7. pubs.acs.org \[pubs.acs.org\]](#)

- 8. Kinase inhibitors can produce off-target effects and activate linked pathways by retroactivity - PMC [[pmc.ncbi.nlm.nih.gov](https://pubmed.ncbi.nlm.nih.gov/)]
- To cite this document: BenchChem. [Interpreting unexpected results with ITX3]. BenchChem, [2026]. [Online PDF]. Available at: [<https://www.benchchem.com/product/b15606329/docs#interpreting-unexpected-results-with-itx3>]

---

### Disclaimer & Data Validity:

The information provided in this document is for Research Use Only (RUO) and is strictly not intended for diagnostic or therapeutic procedures. While BenchChem strives to provide accurate protocols, we make no warranties, express or implied, regarding the fitness of this product for every specific experimental setup.

**Technical Support:** The protocols provided are for reference purposes. Unsure if this reagent suits your experiment?

**Need Industrial/Bulk Grade?** [Request Custom Synthesis Quote](#)

## BenchChem

Our mission is to be the trusted global source of essential and advanced chemicals, empowering scientists and researchers to drive progress in science and industry.

### Contact

Address: 3281 E Guasti Rd  
Ontario, CA 91761, United States  
Phone: (601) 213-4426  
Email: [info@benchchem.com](mailto:info@benchchem.com)

[Contact our Ph.D. Support Team for a compatibility check](#)