

Application Notes: Utilizing ATN-161 in Mouse Models of Metastasis

Author: BenchChem Technical Support Team. **Date:** April 2026

Compound of Interest

Compound Name: ATN-161 trifluoroacetate salt

Cat. No.: B15606112

[Get Quote](#)

Introduction

ATN-161, a pentapeptide (Ac-PHSCN-NH₂), is a non-RGD-based antagonist of integrin $\alpha 5\beta 1$ and $\alpha v\beta 3$.^{[1][2]} Integrins are crucial for tumor progression, playing a significant role in cell adhesion, migration, and angiogenesis.^{[2][3]} ATN-161 functions by binding to the beta subunits of these integrins, which can lock the integrin in an inactive state.^{[1][4][5]} This inhibition of integrin function disrupts downstream signaling pathways, notably the mitogen-activated protein kinase (MAPK) pathway, leading to reduced cell proliferation and angiogenesis.^{[1][3]} Consequently, ATN-161 has demonstrated efficacy in inhibiting tumor growth and metastasis in various preclinical cancer models.^{[3][6][7]}

Mechanism of Action

ATN-161 is derived from the synergy region of fibronectin and acts as a non-competitive inhibitor.^{[4][6]} Its primary targets are integrins $\alpha 5\beta 1$ and $\alpha v\beta 3$, which are often overexpressed on tumor cells and activated endothelial cells.^{[1][2]} By binding to these integrins, ATN-161 interferes with cell-extracellular matrix interactions, which are vital for tumor cell invasion and the formation of new blood vessels (angiogenesis) that supply the tumor.^{[2][8]} Studies have

shown that treatment with ATN-161 leads to a significant decrease in microvessel density within tumors and can induce apoptosis in tumor cells.[3][8]

Signaling Pathway of ATN-161 in Metastasis Inhibition

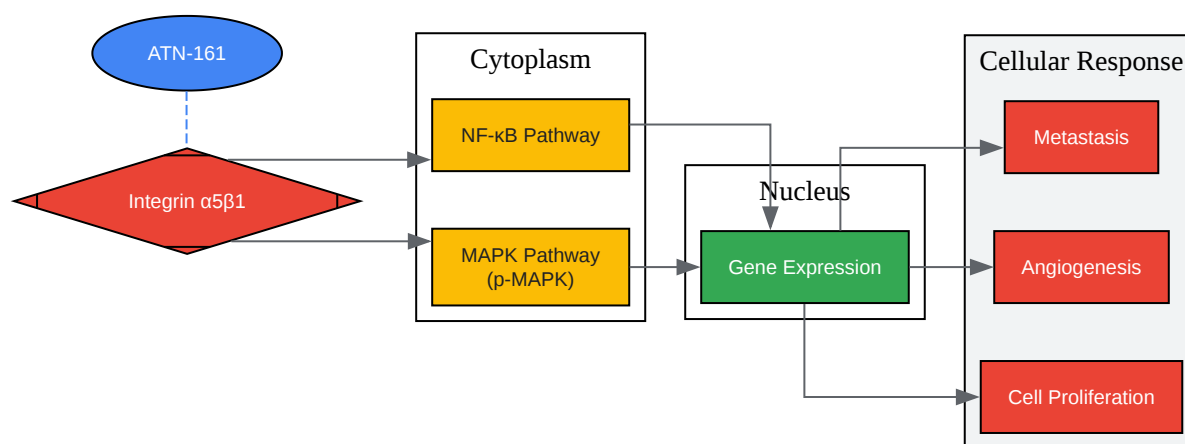

[Click to download full resolution via product page](#)

Caption: ATN-161 inhibits Integrin $\alpha 5\beta 1$ signaling, leading to decreased activation of MAPK and NF- κ B pathways and subsequent reduction in metastasis.

Experimental Protocols

Protocol 1: Orthotopic Breast Cancer Metastasis Model

This protocol is adapted from studies using MDA-MB-231 human breast cancer cells in immunodeficient mice to model skeletal metastasis.[3]

1. Cell Culture and Preparation:

- Culture MDA-MB-231 human breast cancer cells (or a GFP-transfected variant for easier visualization of metastases) in appropriate media (e.g., DMEM with 10% FBS).
- On the day of injection, harvest cells using trypsin, wash with sterile PBS, and resuspend in sterile PBS at a concentration of 1×10^6 cells per 100 μ L.

2. Animal Model:

- Use female BALB/c nu/nu mice, 6-8 weeks of age.

3. Tumor Cell Inoculation:

- For skeletal metastasis, anesthetize mice and inoculate 1×10^5 MDA-MB-231-GFP cells in 100 μ L of PBS into the left ventricle of the heart.
- For primary tumor growth and spontaneous metastasis, inoculate 1×10^6 MDA-MB-231 cells subcutaneously into the right flank.

4. ATN-161 Treatment:

- Prepare ATN-161 in a sterile vehicle (e.g., saline).
- Begin treatment 3-4 days post-inoculation.
- Administer ATN-161 via intravenous infusion at doses ranging from 0.05 to 1 mg/kg, three times a week.[3] A control group should receive vehicle only.

5. Monitoring and Endpoints:

- For subcutaneous tumors, measure tumor volume weekly using calipers (Volume = $0.5 \times \text{length} \times \text{width}^2$).
- Monitor for skeletal metastases using X-ray or microcomputed tomography (μ CT) weekly or bi-weekly.[3]
- Euthanize mice after a predetermined period (e.g., 10 weeks) or when tumors reach a specified size or animals show signs of distress.[3]
- Harvest primary tumors and metastatic tissues (e.g., bone, soft tissues) for histological evaluation.

6. Data Analysis:

- Analyze differences in tumor volume and the incidence and number of metastatic lesions between treatment and control groups.
- Perform immunohistochemistry on harvested tissues to assess microvessel density (e.g., CD31 staining) and cell proliferation (e.g., Ki-67 staining).[3]

Protocol 2: Experimental Liver Metastasis Model

This protocol is based on a murine colon cancer model to assess the effect of ATN-161 on liver metastases.[8][9]

1. Cell Culture and Preparation:

- Culture CT26 murine colon carcinoma cells in an appropriate medium.
- Prepare a single-cell suspension of 1×10^5 cells in 50 μ L of sterile Hank's Balanced Salt Solution (HBSS).[10]

2. Animal Model:

- Use male BALB/c mice, 8 weeks of age.[10]

3. Tumor Cell Inoculation:

- Anesthetize mice and perform a laparotomy to expose the spleen.
- Inject the CT26 cell suspension into the spleen to induce liver metastases.[8][10]

4. ATN-161 Treatment:

- Four days after tumor cell injection, begin treatment with ATN-161.
- Administer ATN-161 via intraperitoneal injection at a dose of 100 mg/kg every third day.[8][9]
A control group should receive saline.
- This protocol can be adapted to include combination therapy, for example, with 5-fluorouracil (5-FU).[8]

5. Monitoring and Endpoints:

- Euthanize mice on day 20 after tumor cell inoculation.[8][9]
- Excise the livers and weigh them to determine tumor burden.
- Count the number of visible liver metastases on the surface of the liver.

6. Data Analysis:

- Compare liver weights and the number of metastases between the different treatment groups.
- Perform histological analysis of liver tumors to assess microvessel density, tumor cell apoptosis (e.g., TUNEL assay), and proliferation.[8]

Experimental Workflow for Metastasis Study

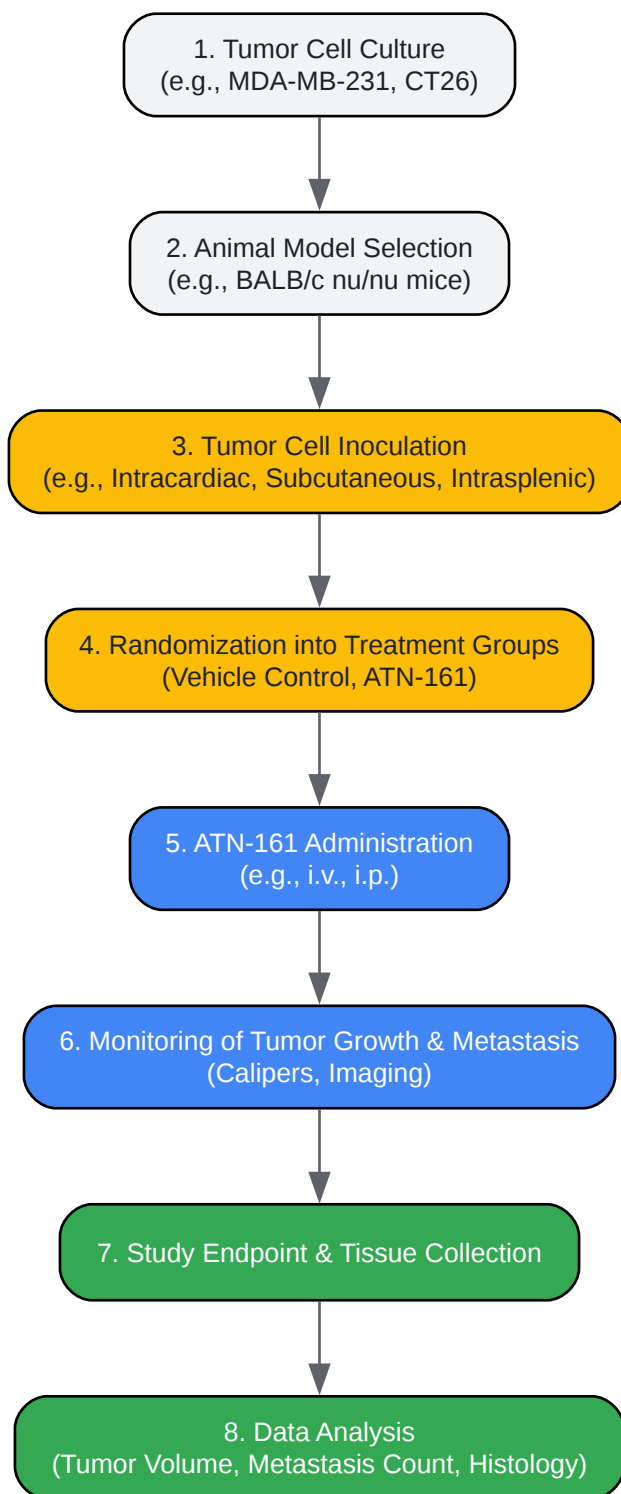

[Click to download full resolution via product page](#)

Caption: A generalized workflow for evaluating the efficacy of ATN-161 in a mouse model of metastasis.

Data Presentation

Table 1: Efficacy of ATN-161 on Primary Tumor Growth

Cancer Model	Cell Line	Mouse Strain	ATN-161 Dose	Route	Outcome	Reference
Breast Cancer	MDA-MB-231	BALB/c nu/nu	0.05-1 mg/kg	i.v.	Significant dose-dependent decrease in tumor volume	[3]
MLL Tumor	MLL	Copenhagen Rats	5 mg/kg	Systemic	Marked reduction in primary tumor growth	[5]
Melanoma	B16F10	C57BL/6	100 mg/kg (as DOX-ATN/SCID-Ps)	i.v.	Significant inhibition of tumor growth	[11]

Table 2: Efficacy of ATN-161 on Metastasis

Cancer Model	Cell Line	Mouse Strain	ATN-161 Dose	Route	Outcome	Reference
Breast Cancer (Skeletal Metastasis)	MDA-MB-231-GFP	BALB/c nu/nu	0.05-1 mg/kg	i.v.	Complete block or marked decrease in skeletal and soft tissue metastases	[3]
Colon Cancer (Liver Metastasis)	CT26	BALB/c	100 mg/kg	i.p.	Significant reduction in the number of liver metastases	[8][9]
MLL Tumor	MLL	Copenhagen Rats	5 mg/kg	Systemic	Inhibition of metastasis	[5]

Table 3: Histological and Biomarker Analysis

Cancer Model	Cell Line	ATN-161 Treatment	Effect on Microvessel Density	Effect on Cell Proliferation	Other Notable Effects	Reference
Breast Cancer	MDA-MB-231	0.05-1 mg/kg, i.v.	Significant decrease	Significant decrease	Significant decrease in phosphorylated MAPK	[3]
Colon Cancer	CT26	100 mg/kg, i.p.	Significant decrease	Significant decrease (with 5-FU)	Significant increase in tumor cell apoptosis (with 5-FU)	[8]
MLL Tumor	MLL	5 mg/kg, systemic	8- to 10-fold lower blood vessel density	Not directly assessed	-	[5]

References

- 1. [selleckchem.com](https://www.selleckchem.com) [selleckchem.com]
- 2. [go.drugbank.com](https://www.go.drugbank.com) [go.drugbank.com]
- 3. A non-RGD-based integrin binding peptide (ATN-161) blocks breast cancer growth and metastasis in vivo - PubMed [pubmed.ncbi.nlm.nih.gov]
- 4. [mdpi.com](https://www.mdpi.com) [mdpi.com]
- 5. Phase 1 trial of the antiangiogenic peptide ATN-161 (Ac-PHSCN-NH₂), a beta integrin antagonist, in patients with solid tumours - PMC [pmc.ncbi.nlm.nih.gov]
- 6. ATN-161 as an Integrin $\alpha 5\beta 1$ Antagonist Depresses Ocular Neovascularization by Promoting New Vascular Endothelial Cell Apoptosis - PMC [pmc.ncbi.nlm.nih.gov]
- 7. ATN 161 | Integrins | Tocris Bioscience [tocris.com]

- 8. Inhibition of integrin alpha5beta1 function with a small peptide (ATN-161) plus continuous 5-FU infusion reduces colorectal liver metastases and improves survival in mice - PubMed [pubmed.ncbi.nlm.nih.gov]
- 9. deepdyve.com [deepdyve.com]
- 10. medchemexpress.com [medchemexpress.com]
- 11. ATN-161 Peptide Functionalized Reversibly Cross-Linked Polymersomes Mediate Targeted Doxorubicin Delivery into Melanoma-Bearing C57BL/6 Mice - PubMed [pubmed.ncbi.nlm.nih.gov]
- To cite this document: BenchChem. [Application Notes: Utilizing ATN-161 in Mouse Models of Metastasis]. BenchChem, [2026]. [Online PDF]. Available at: [<https://www.benchchem.com/product/b15606112/docs#application-notes-utilizing-atn-161-in-mouse-models-of-metastasis>]

Disclaimer & Data Validity:

The information provided in this document is for Research Use Only (RUO) and is strictly not intended for diagnostic or therapeutic procedures. While BenchChem strives to provide accurate protocols, we make no warranties, express or implied, regarding the fitness of this product for every specific experimental setup.

Technical Support: The protocols provided are for reference purposes. Unsure if this reagent suits your experiment?

Need Industrial/Bulk Grade? [Request Custom Synthesis Quote](#)

BenchChem

Our mission is to be the trusted global source of essential and advanced chemicals, empowering scientists and researchers to drive progress in science and industry.

Contact

Address: 3281 E Guasti Rd
Ontario, CA 91761, United States
Phone: (601) 213-4426
Email: info@benchchem.com

Contact our Ph.D. Support Team for a compatibility check