

# Application Notes: AlphaLISA-Based MLL HMT Functional Assay with MM-589

**Author:** BenchChem Technical Support Team. **Date:** April 2026

## Compound of Interest

Compound Name: MM-589 TFA

Cat. No.: B15606097

[Get Quote](#)

For Research Use Only. Not for use in diagnostic procedures.

## Introduction

The Mixed Lineage Leukemia (MLL) family of histone methyltransferases (HMTs) plays a critical role in regulating gene expression through the methylation of histone H3 at lysine 4 (H3K4). Dysregulation of MLL activity is implicated in various cancers, particularly acute leukemias. The interaction between MLL and the WD repeat domain 5 (WDR5) protein is essential for the catalytic activity of the MLL complex. Consequently, targeting the MLL-WDR5 protein-protein interaction (PPI) has emerged as a promising therapeutic strategy. MM-589 is a potent and cell-permeable inhibitor that specifically disrupts this interaction.[1][2]

This application note provides a detailed protocol for an AlphaLISA (Amplified Luminescent Proximity Homogeneous Assay) based functional assay to measure MLL HMT activity and its inhibition by compounds such as MM-589. The AlphaLISA technology offers a sensitive, no-wash, bead-based assay format suitable for high-throughput screening (HTS).[3][4][5][6]

## Principle of the Assay

The AlphaLISA assay quantifies the methylation of a biotinylated histone H3 peptide substrate by the MLL enzyme complex. The assay utilizes two types of beads: Streptavidin-coated Donor beads and Acceptor beads conjugated to an antibody specific for the methylated histone mark. When the MLL enzyme methylates the biotinylated substrate, the Donor beads bind to the biotin tag, and the Acceptor beads bind to the methyl mark. This brings the beads into close proximity (<200 nm). Upon excitation of the Donor beads at 680 nm, singlet oxygen is generated, which diffuses to the nearby Acceptor beads, triggering a chemiluminescent signal at 615 nm. The intensity of the emitted light is directly proportional to the level of substrate methylation. Inhibitors of MLL HMT activity will decrease the signal.[3][4][5][6]

## Data Presentation

Table 1: Inhibitory Activity of MM-589

Target	Assay	IC50	Reference
MLL H3K4 Methyltransferase Activity	AlphaLISA-based HMT Assay	12.7 nM	[1][7]
WDR5 Binding	Biochemical Assay	0.90 nM	[1][7]

Table 2: Cellular Activity of MM-589 in MLL-rearranged Leukemia Cell Lines

Cell Line	Type	IC50	Reference
MV4-11	MLL-AF4	0.25 µM	[1]
MOLM-13	MLL-AF9	0.21 µM	[1]
HL-60	MLL-wildtype	8.6 µM	[1]

## Mandatory Visualizations

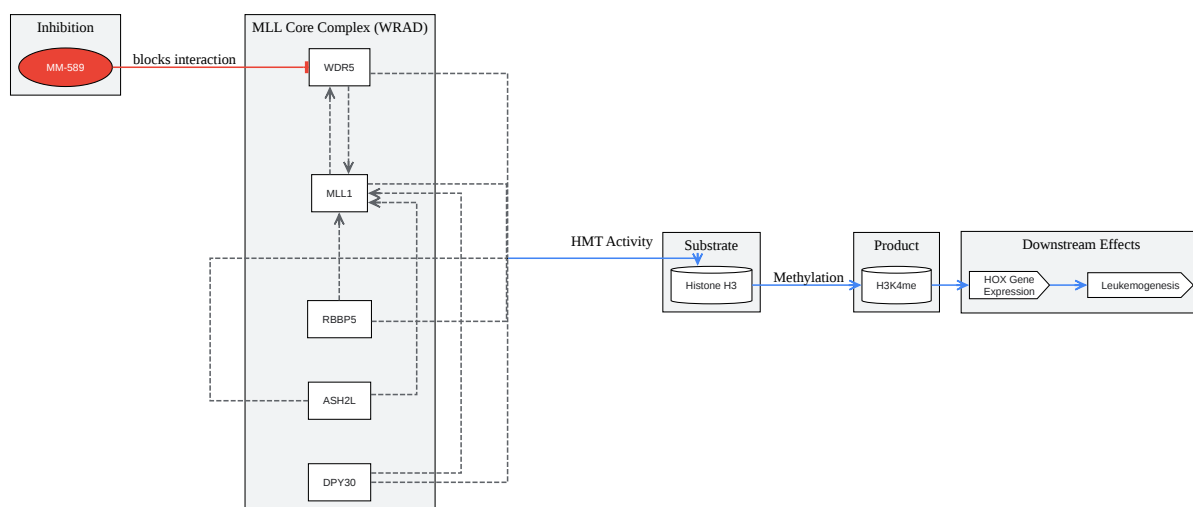

[Click to download full resolution via product page](#)

Caption: MLL Signaling Pathway and MM-589 Inhibition.

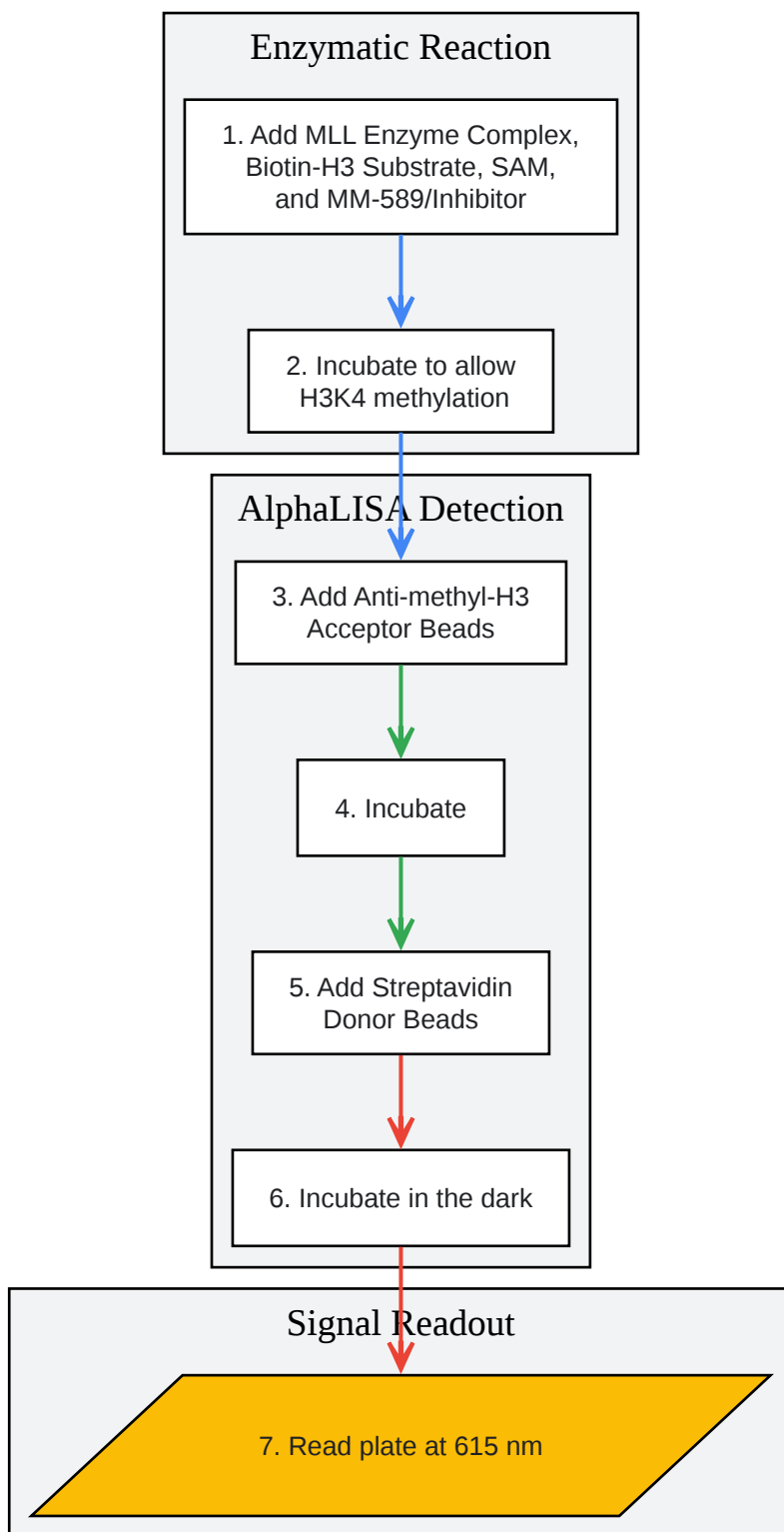

[Click to download full resolution via product page](#)

Caption: AlphaLISA MLL HMT Assay Workflow.

## Experimental Protocols

### Materials and Reagents

- Enzyme: Recombinant MLL core complex (containing MLL, WDR5, ASH2L, RBBP5, and DPY30)
- Substrate: Biotinylated Histone H3 (1-21) peptide
- Cofactor: S-adenosyl-L-methionine (SAM)
- Inhibitor: MM-589
- Detection Reagents:
  - AlphaLISA® Anti-methyl-Histone H3 Acceptor beads
  - AlphaLISA® Streptavidin Donor beads
- Assay Buffer: e.g., 50 mM Tris-HCl pH 8.0, 50 mM NaCl, 1 mM DTT, 0.01% Tween-20, 0.005% BSA
- Detection Buffer: e.g., 1x AlphaLISA Epigenetics Buffer
- Plates: 384-well white opaque assay plates
- Plate Reader: An AlphaScreen®-enabled plate reader

### Assay Protocol

- Compound Preparation:
  - Prepare a stock solution of MM-589 in 100% DMSO.
  - Perform serial dilutions of the compound in assay buffer to the desired final concentrations. The final DMSO concentration in the assay should not exceed 1%.
- Enzyme Reaction:

- Add 2.5  $\mu$ L of the diluted compound or vehicle (assay buffer with DMSO) to the wells of a 384-well plate.
- Add 2.5  $\mu$ L of the MLL enzyme complex (at 2x final concentration) to each well.
- Pre-incubate for 15 minutes at room temperature.
- Initiate the reaction by adding 5  $\mu$ L of a mixture of biotinylated H3 peptide substrate and SAM (at 2x final concentration).
- Seal the plate and incubate for 60 minutes at room temperature.
- AlphaLISA Detection:
  - Prepare the Anti-methyl-Histone H3 Acceptor beads by diluting them in 1x AlphaLISA Epigenetics Buffer.
  - Add 5  $\mu$ L of the diluted Acceptor beads to each well.
  - Seal the plate and incubate for 60 minutes at room temperature in the dark.
  - Prepare the Streptavidin Donor beads by diluting them in 1x AlphaLISA Epigenetics Buffer under subdued light.
  - Add 10  $\mu$ L of the diluted Donor beads to each well.
  - Seal the plate and incubate for 30 minutes at room temperature in the dark.
- Signal Measurement:
  - Read the plate on an AlphaScreen-enabled plate reader with excitation at 680 nm and emission detection at 615 nm.

## Data Analysis

The inhibitory effect of MM-589 can be determined by calculating the IC<sub>50</sub> value from a dose-response curve. The data is typically normalized to the high control (enzyme, substrate, and

vehicle) and low control (no enzyme or a known potent inhibitor). The IC50 value is the concentration of the inhibitor that reduces the enzyme activity by 50%.

## Conclusion

The AlphaLISA-based MLL HMT functional assay is a robust and sensitive method for characterizing the activity of MLL inhibitors like MM-589. Its homogeneous format and high-throughput compatibility make it an ideal tool for drug discovery and development efforts targeting the MLL-WDR5 interaction. The data presented here demonstrates the potent and specific inhibition of MLL HMT activity by MM-589, supporting its further investigation as a potential therapeutic agent for MLL-rearranged leukemias.

### *Need Custom Synthesis?*

*BenchChem offers custom synthesis for rare earth carbides and specific isotopic labeling.*

*Email: [info@benchchem.com](mailto:info@benchchem.com) or [Request Quote Online](#).*

## References

- [1. MLL1/WDR5 complex in leukemogenesis and epigenetic regulation - PMC \[pmc.ncbi.nlm.nih.gov\]](#)
- [2. Development of Multiple Cell-Based Assays for the Detection of Histone H3 Lys27 Trimethylation \(H3K27me3\) - PMC \[pmc.ncbi.nlm.nih.gov\]](#)
- [3. WDR5 Interacts with Mixed Lineage Leukemia \(MLL\) Protein via the Histone H3-binding Pocket - PMC \[pmc.ncbi.nlm.nih.gov\]](#)
- [4. Pharmacological targeting of the Wdr5-MLL interaction in C/EBP \$\alpha\$  N-terminal leukemia - PMC \[pmc.ncbi.nlm.nih.gov\]](#)
- [5. researchgate.net \[researchgate.net\]](#)
- [6. uniprot.org \[uniprot.org\]](#)
- [7. researchgate.net \[researchgate.net\]](#)
- To cite this document: BenchChem. [Application Notes: AlphaLISA-Based MLL HMT Functional Assay with MM-589]. BenchChem, [2026]. [Online PDF]. Available at: [<https://www.benchchem.com/product/b15606097/docs#application-notes-alpha-lisa-based-ml-l-hmt-functional-assay-with-mm-589>]

**Disclaimer & Data Validity:**

The information provided in this document is for Research Use Only (RUO) and is strictly not intended for diagnostic or therapeutic procedures. While BenchChem strives to provide accurate protocols, we make no warranties, express or implied, regarding the fitness of this product for every specific experimental setup.

**Technical Support:** The protocols provided are for reference purposes. Unsure if this reagent suits your experiment?

**Need Industrial/Bulk Grade?** [Request Custom Synthesis Quote](#)

## BenchChem

Our mission is to be the trusted global source of essential and advanced chemicals, empowering scientists and researchers to drive progress in science and industry.

### Contact

Address: 3281 E Guasti Rd  
Ontario, CA 91761, United States  
Phone: (601) 213-4426  
Email: [info@benchchem.com](mailto:info@benchchem.com)

[Contact our Ph.D. Support Team for a compatibility check](#)