

# Validating MIF Inhibitors: A Comparative Guide Using a MIF Knockout Model

**Author:** BenchChem Technical Support Team. **Date:** April 2026

## Compound of Interest

Compound Name: *Mif-IN-6*  
Cat. No.: *B15605763*

[Get Quote](#)

For researchers, scientists, and drug development professionals, validating the specificity and efficacy of a novel therapeutic agent is a critical step. This guide provides a comparative framework for validating the inhibitory effect of a Macrophage Migration Inhibitory Factor (MIF) inhibitor, using a MIF knockout (KO) mouse model as the gold standard for specificity. Here, we use the experimental data from a study on LPS-induced liver injury to illustrate this validation process, comparing the effects of two small molecule MIF inhibitors, ISO-1 and 4-IPP, against the phenotype observed in MIF KO mice.

Macrophage Migration Inhibitory Factor (MIF) is a pleiotropic cytokine that plays a crucial role in the pathogenesis of various inflammatory diseases. Its inhibition is a promising therapeutic strategy. However, to ensure that the effects of a MIF inhibitor are truly due to its intended mechanism of action, it is essential to compare its performance with a model where the target is absent. The MIF knockout mouse provides this ideal negative control.

## Comparative Analysis of MIF Inhibition in LPS-Induced Liver Injury

In a model of lipopolysaccharide (LPS)-induced liver injury, the absence of MIF (in MIF KO mice) or its inhibition by small molecules is expected to ameliorate liver damage and reduce the

inflammatory response. The following tables summarize the key quantitative data from a study by Gu et al. (2021), which demonstrates this principle.

**Table 1: Effect of MIF Inhibition on Liver Function Markers**

| Group          | ALT (U/L)        | AST (U/L)        | TBil ( $\mu\text{mol/L}$ ) |
|----------------|------------------|------------------|----------------------------|
| Control        | 45.2 $\pm$ 5.1   | 120.5 $\pm$ 12.3 | 2.1 $\pm$ 0.3              |
| LPS-WT         | 285.6 $\pm$ 25.8 | 540.2 $\pm$ 45.1 | 8.5 $\pm$ 1.2              |
| LPS-MIF KO     | 110.3 $\pm$ 10.2 | 250.8 $\pm$ 22.5 | 4.2 $\pm$ 0.6              |
| LPS-WT + ISO-1 | 135.4 $\pm$ 12.9 | 280.1 $\pm$ 25.7 | 4.8 $\pm$ 0.7              |
| LPS-WT + 4-IPP | 150.7 $\pm$ 15.1 | 310.6 $\pm$ 30.2 | 5.1 $\pm$ 0.8              |

Data are presented as mean  $\pm$  SD. Data is representative of findings in Gu et al., 2021.

**Table 2: Effect of MIF Inhibition on Serum Inflammatory Cytokines**

| Group          | TNF- $\alpha$ (pg/mL) | IL-1 $\beta$ (pg/mL) |
|----------------|-----------------------|----------------------|
| Control        | 30.1 $\pm$ 4.5        | 25.4 $\pm$ 3.9       |
| LPS-WT         | 250.8 $\pm$ 22.1      | 180.5 $\pm$ 15.6     |
| LPS-MIF KO     | 105.2 $\pm$ 11.2      | 85.3 $\pm$ 9.1       |
| LPS-WT + ISO-1 | 120.6 $\pm$ 13.5      | 95.8 $\pm$ 10.2      |
| LPS-WT + 4-IPP | 130.4 $\pm$ 14.1      | 102.1 $\pm$ 11.5     |

Data are presented as mean  $\pm$  SD. Data is representative of findings in Gu et al., 2021.

## Experimental Protocols

Detailed methodologies are crucial for the reproducibility and validation of experimental findings. The following protocols are based on the study by Gu et al. (2021).

## Animal Model of LPS-Induced Liver Injury

- **Animals:** Male C57BL/6 wild-type (WT) and MIF knockout (MIF<sup>-/-</sup>) mice, 8-10 weeks old, are used. All animals are housed in a specific pathogen-free facility with ad libitum access to food and water.
- **Induction of Liver Injury:** Mice are intraperitoneally injected with Lipopolysaccharide (LPS) from *Escherichia coli* O111:B4 at a dose of 10 mg/kg body weight. Control animals receive an equivalent volume of sterile saline.
- **Sample Collection:** 72 hours post-LPS injection, mice are anesthetized, and blood samples are collected via cardiac puncture for serum analysis. Liver tissues are harvested for histopathological and molecular analysis.

## Administration of MIF Inhibitors

- **Inhibitors:** (S,R)-3-(4-hydroxyphenyl)-4,5-dihydro-5-isoxazole acetic acid methyl ester (ISO-1) and 4-iodo-6-phenylpyrimidine (4-IPP) are used as MIF inhibitors.
- **Preparation and Dosing:** Inhibitors are dissolved in a vehicle solution (e.g., DMSO and saline).
- **Administration:** Mice in the treatment groups receive an intraperitoneal injection of either ISO-1 (20 mg/kg) or 4-IPP (10 mg/kg) one hour prior to LPS administration. The control group for the inhibitors receives a vehicle injection.

## Biochemical Analysis of Liver Function

- Serum levels of alanine aminotransferase (ALT), aspartate aminotransferase (AST), and total bilirubin (TBil) are measured using commercially available assay kits according to the manufacturer's instructions.

## Measurement of Inflammatory Cytokines

- Serum concentrations of tumor necrosis factor-alpha (TNF- $\alpha$ ) and interleukin-1beta (IL-1 $\beta$ ) are quantified using enzyme-linked immunosorbent assay (ELISA) kits as per the manufacturer's protocols.

## Visualizing Pathways and Workflows

### MIF Signaling Pathway

The following diagram illustrates the key signaling pathways activated by MIF. Inhibition of MIF by small molecules or its absence in a knockout model is expected to block these downstream effects.

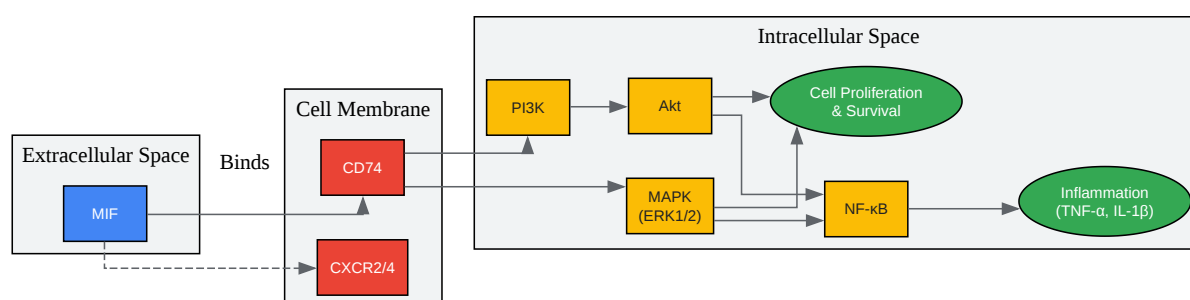

[Click to download full resolution via product page](#)

Caption: Simplified MIF signaling pathway.

### Experimental Workflow for Inhibitor Validation

This diagram outlines the logical flow of an experiment designed to validate a MIF inhibitor using a MIF knockout model.

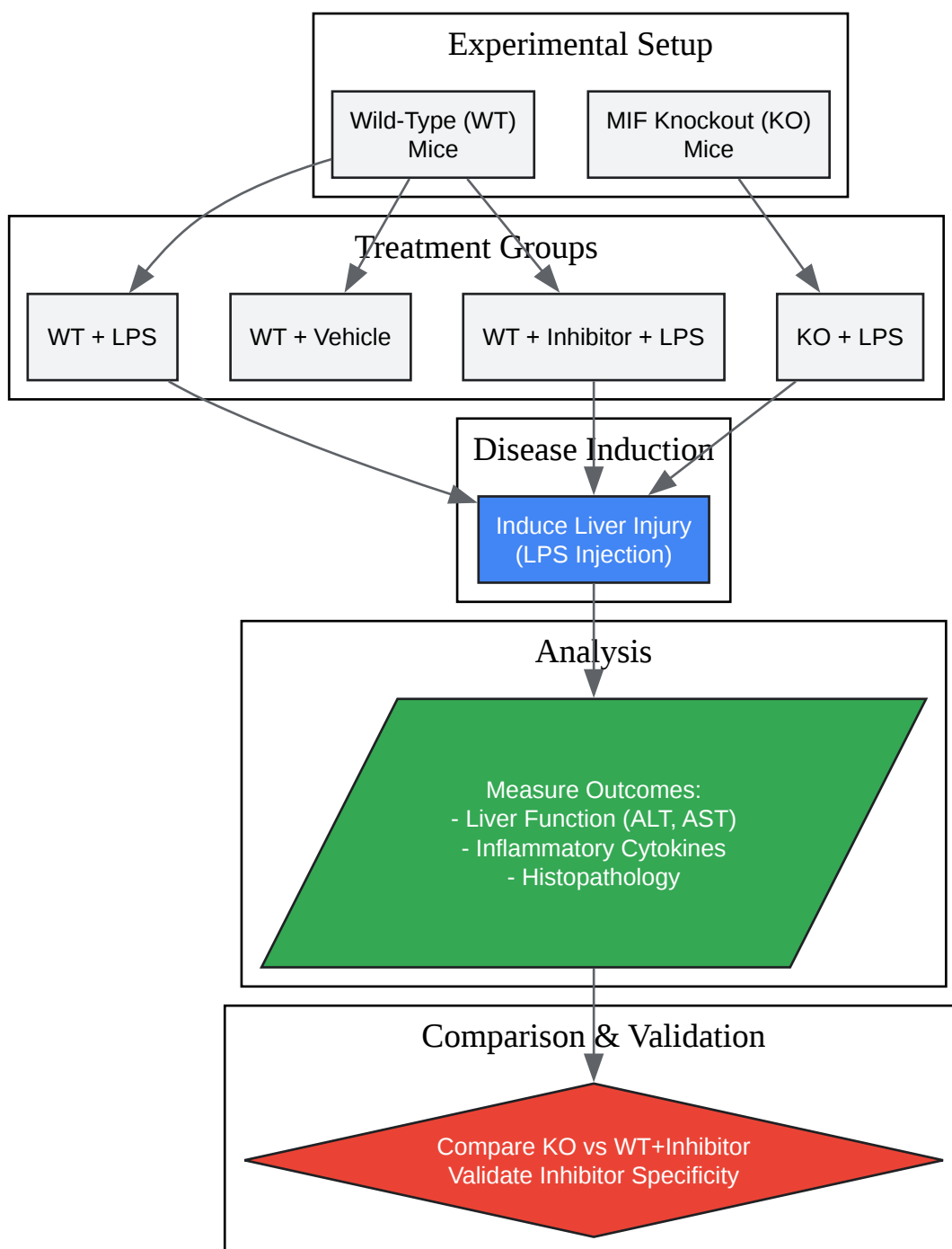

[Click to download full resolution via product page](#)

Caption: Workflow for validating a MIF inhibitor.

In conclusion, the congruence between the phenotype of MIF knockout mice and the effects of a specific MIF inhibitor in a disease model provides strong evidence for the inhibitor's on-target

activity. This comparative approach is indispensable for the preclinical validation of novel MIF-targeted therapeutics.

- To cite this document: BenchChem. [Validating MIF Inhibitors: A Comparative Guide Using a MIF Knockout Model]. BenchChem, [2026]. [Online PDF]. Available at: [<https://www.benchchem.com/product/b15605763/docs#validating-mif-inhibitors-a-comparative-guide-using-a-mif-knockout-model>]

---

### Disclaimer & Data Validity:

The information provided in this document is for Research Use Only (RUO) and is strictly not intended for diagnostic or therapeutic procedures. While BenchChem strives to provide accurate protocols, we make no warranties, express or implied, regarding the fitness of this product for every specific experimental setup.

**Technical Support:** The protocols provided are for reference purposes. Unsure if this reagent suits your experiment?

**Need Industrial/Bulk Grade?** [Request Custom Synthesis Quote](#)

## BenchChem

Our mission is to be the trusted global source of essential and advanced chemicals, empowering scientists and researchers to drive progress in science and industry.

### Contact

Address: 3281 E Guasti Rd  
Ontario, CA 91761, United States  
Phone: (601) 213-4426  
Email: [info@benchchem.com](mailto:info@benchchem.com)

[Contact our Ph.D. Support Team for a compatibility check](#)

