

# Technical Support Center: Optimizing gp33-41 Peptide Stimulation of T Cells

**Author:** BenchChem Technical Support Team. **Date:** April 2026

## Compound of Interest

Compound Name: LCMV gp33-41

Cat. No.: B15605956

[Get Quote](#)

This technical support center provides troubleshooting guidance and answers to frequently asked questions for researchers using the lymphocytic choriomeningitis virus (LCMV) glycoprotein-derived peptide, gp33-41, for T cell stimulation experiments.

## Frequently Asked Questions (FAQs)

Q1: What is the gp33-41 peptide and what is its primary application?

The gp33-41 peptide, with the core sequence KAVYNFATC, is an immunodominant epitope derived from the lymphocytic choriomeningitis virus (LCMV) glycoprotein.[1][2][3] It is presented by the Major Histocompatibility Complex (MHC) class I molecule H-2Db in C57BL/6 mice and is recognized by CD8+ cytotoxic T lymphocytes (CTLs).[4] Its primary application is in immunology research for the in vitro and ex vivo stimulation of gp33-41-specific CD8+ T cells to study T cell activation, cytokine production, proliferation, and cytotoxicity.

Q2: There are different sequences available for gp33-41 (e.g., ending in -ATC vs. -ATM). Which one should I use?

The native sequence is KAVYNFATC (41C).[3][5] An altered peptide ligand (APL) where the terminal Cysteine (C) is replaced by a Methionine (M), KAVYNFATM (41M), is also widely used.

[5] The 41M variant was developed because the terminal cysteine in the 41C version can form peptide dimers and has been shown to have decreased stability when bound to the MHC molecule.[5] Studies have shown that the 41M APL exhibits a higher binding affinity to the T cell receptor (TCR) and may induce a stronger T cell response in terms of cytokine production (IFN $\gamma$ , IL-2) compared to the native 41C sequence.[5] The choice depends on the experimental goal; 41M is often preferred for inducing robust responses in vitro, while 41C represents the native epitope.

Q3: How should I reconstitute and store my lyophilized gp33-41 peptide?

For reconstitution, sterile, endotoxin-free solvents are critical.

- Solvents: For peptides with low solubility in aqueous solutions, it is recommended to first use an organic solvent like DMSO and then gradually add water or culture medium to reach the desired concentration.[6] Water (H<sub>2</sub>O) can also be used, sometimes requiring sonication to fully dissolve the peptide.[4][6]
- Stock Solutions: Prepare a high-concentration stock solution (e.g., 1-10 mM in DMSO). Once prepared, aliquot the stock solution into single-use volumes to prevent product degradation from repeated freeze-thaw cycles.[4]
- Storage:
  - Lyophilized Powder: Store at -20°C for long-term storage (up to 1 year) or -80°C (up to 2 years).[4] For short periods of days to weeks, it is stable at room temperature.[7]
  - In Solution: Store aliquots at -80°C for up to 6 months or -20°C for up to 1 month.[4][7] Avoid repeated freeze-thaw cycles.[4]

## Troubleshooting Guide

Q4: I am not seeing any T cell activation (e.g., no IFN- $\gamma$  production) after peptide stimulation. What could be the problem?

This is a common issue with several potential causes:

- **Incorrect Peptide Concentration:** The optimal concentration needs to be determined empirically. A typical starting concentration for in vitro restimulation is 1  $\mu\text{M}$ .<sup>[8]</sup> Titrate the peptide concentration over a range (e.g., 0.01  $\mu\text{M}$  to 10  $\mu\text{M}$ ) to find the optimal dose for your specific cells and assay.
- **Peptide Degradation:** Ensure the peptide has been stored correctly and that stock solutions have not undergone multiple freeze-thaw cycles.<sup>[4]</sup> If in doubt, use a fresh vial of peptide or a newly prepared stock solution.
- **Low Frequency of Antigen-Specific T Cells:** If you are using cells directly ex vivo, the frequency of gp33-specific T cells may be too low to detect. Consider using cells from mice at the peak of an immune response (e.g., day 8 post-LCMV infection) or using T cell receptor (TCR) transgenic T cells, such as P14 cells, which are specific for gp33-41.<sup>[8][9]</sup>
- **Suboptimal Stimulation Time:** For intracellular cytokine staining (ICS), a stimulation period of 5-6 hours is standard.<sup>[10][11]</sup> Shorter times may not be sufficient to induce detectable cytokine production, while much longer times can lead to T cell exhaustion or apoptosis.
- **Issues with Antigen Presenting Cells (APCs):** CD8<sup>+</sup> T cells require the peptide to be presented by APCs on MHC class I molecules. If using purified CD8<sup>+</sup> T cells, ensure you have added a source of APCs, such as irradiated splenocytes.<sup>[8]</sup>

Q5: My intracellular cytokine staining (ICS) results show high background or non-specific staining. How can I reduce this?

High background can obscure positive signals. Here are some troubleshooting steps:

- **Protein Transport Inhibitor Incubation Time:** Brefeldin A or Monensin are crucial for retaining cytokines intracellularly, but prolonged exposure can be toxic. Limit the incubation with these inhibitors to the last 4-6 hours of the stimulation culture.<sup>[10][12]</sup>
- **Viability Dye:** Always include a viability dye in your staining panel to exclude dead cells from the analysis.<sup>[13]</sup> Dead cells can non-specifically bind antibodies, leading to false-positive signals.<sup>[13]</sup>
- **Fc Receptor Blockade:** Before adding specific antibodies, incubate cells with an Fc receptor blocking antibody (e.g., anti-CD16/32 for mouse cells) to prevent non-specific binding to Fc

receptors on cells like macrophages and B cells.

- **Antibody Titration:** Use the optimal concentration of your fluorescently-labeled antibodies. Using too much antibody can increase background staining. Perform a titration experiment for each new antibody-fluorophore conjugate.
- **Washing Steps:** Ensure adequate washing between staining steps to remove unbound antibodies.[13][14]

Q6: The percentage of cytokine-positive T cells is lower than expected. How can I optimize the signal?

- **Co-stimulation:** T cell activation is enhanced by co-stimulatory signals. While peptide stimulation alone can be sufficient, adding a co-stimulatory antibody like anti-CD28 (at ~1-2 µg/mL) during the culture can increase the magnitude of the response.
- **Optimize Cell Density:** Culture cells at an optimal density, typically between  $1-2 \times 10^6$  cells/mL.[13] Too high a density can lead to nutrient depletion and cell death, while too low a density can result in insufficient cell-to-cell contact.
- **Choice of Peptide Variant:** As mentioned in Q2, the KAVYNFATM (41M) variant may produce a more robust response than the native KAVYNFATC (41C) sequence due to higher TCR affinity.[5] Consider testing this variant if your signal is weak.

## Quantitative Data Summary

For easy reference, the following tables summarize typical quantitative parameters used in gp33-41 T cell stimulation experiments.

Table 1: Recommended Peptide Concentrations for T Cell Assays

Assay Type	Peptide Variant	Typical Concentration Range	Reference
Intracellular Cytokine Staining (ICS)	gp33-41 (WT or APLs)	0.1 $\mu$ M - 10 $\mu$ M	[5]
In Vitro Restimulation / Cytokine ELISA	gp33-41	~1 $\mu$ M	[8]
In Vivo Cytotoxicity Assay (Target Cell Pulsing)	gp33-41	1 $\mu$ M	[15]
Sensitization for Lysis (ED <sub>50</sub> )	gp33-41	0.9 - 2.5 nM	[16]

Table 2: Typical Cell Culture and Incubation Parameters

Parameter	Recommended Value	Reference
Cell Density	1 - 2 x 10 <sup>6</sup> cells/mL	[13]
Total Stimulation Time (for ICS)	5 - 6 hours	[10][11]
Protein Transport Inhibitor Incubation	Final 4 - 6 hours of culture	[10][12]
Incubation Temperature	37°C, 5% CO <sub>2</sub>	[8][17]

## Visual Guides and Workflows

### T Cell Activation Pathway

## Simplified TCR Signaling for Cytokine Production

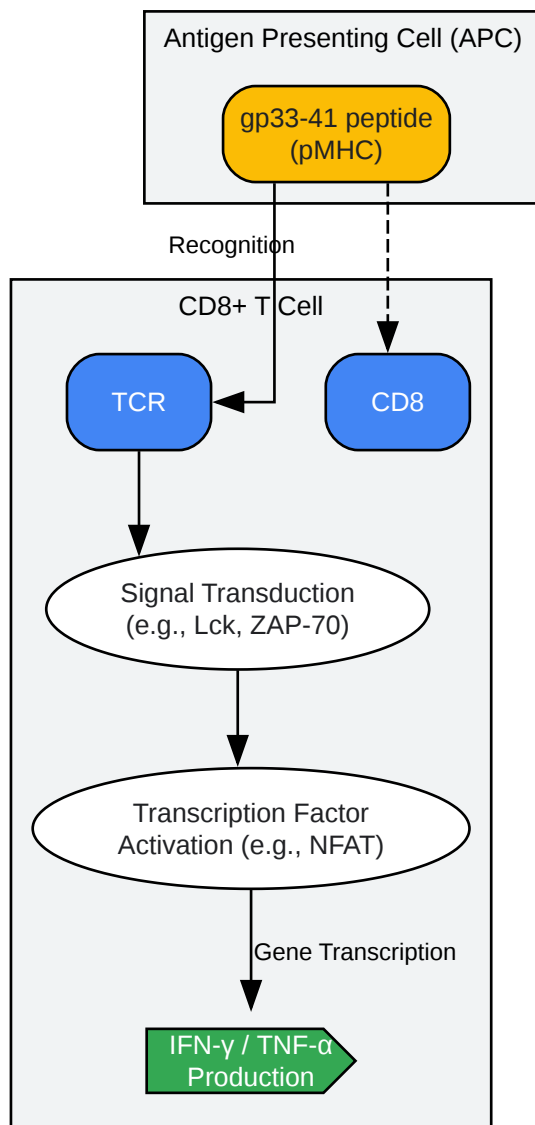

[Click to download full resolution via product page](#)

Caption: TCR recognition of gp33-pMHC initiates signaling for cytokine production.

## Experimental Workflow for Intracellular Cytokine Staining

Workflow: gp33-41 Stimulation and Intracellular Cytokine Staining

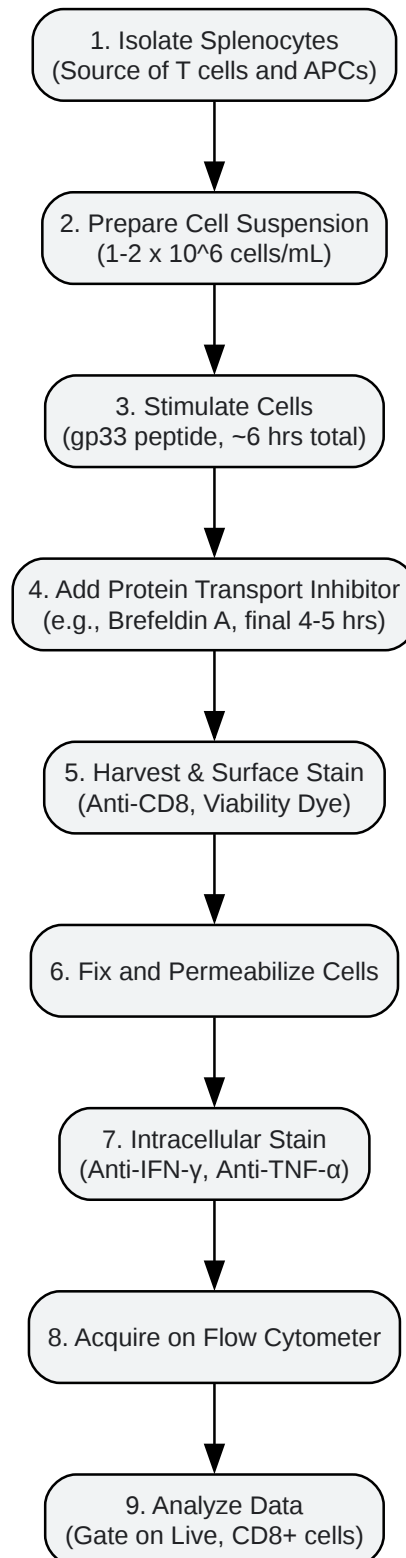

[Click to download full resolution via product page](#)

Caption: Step-by-step workflow for measuring T cell cytokine response to gp33.

# Troubleshooting Logic for Low Signal

Troubleshooting: Low Cytokine Signal in ICS

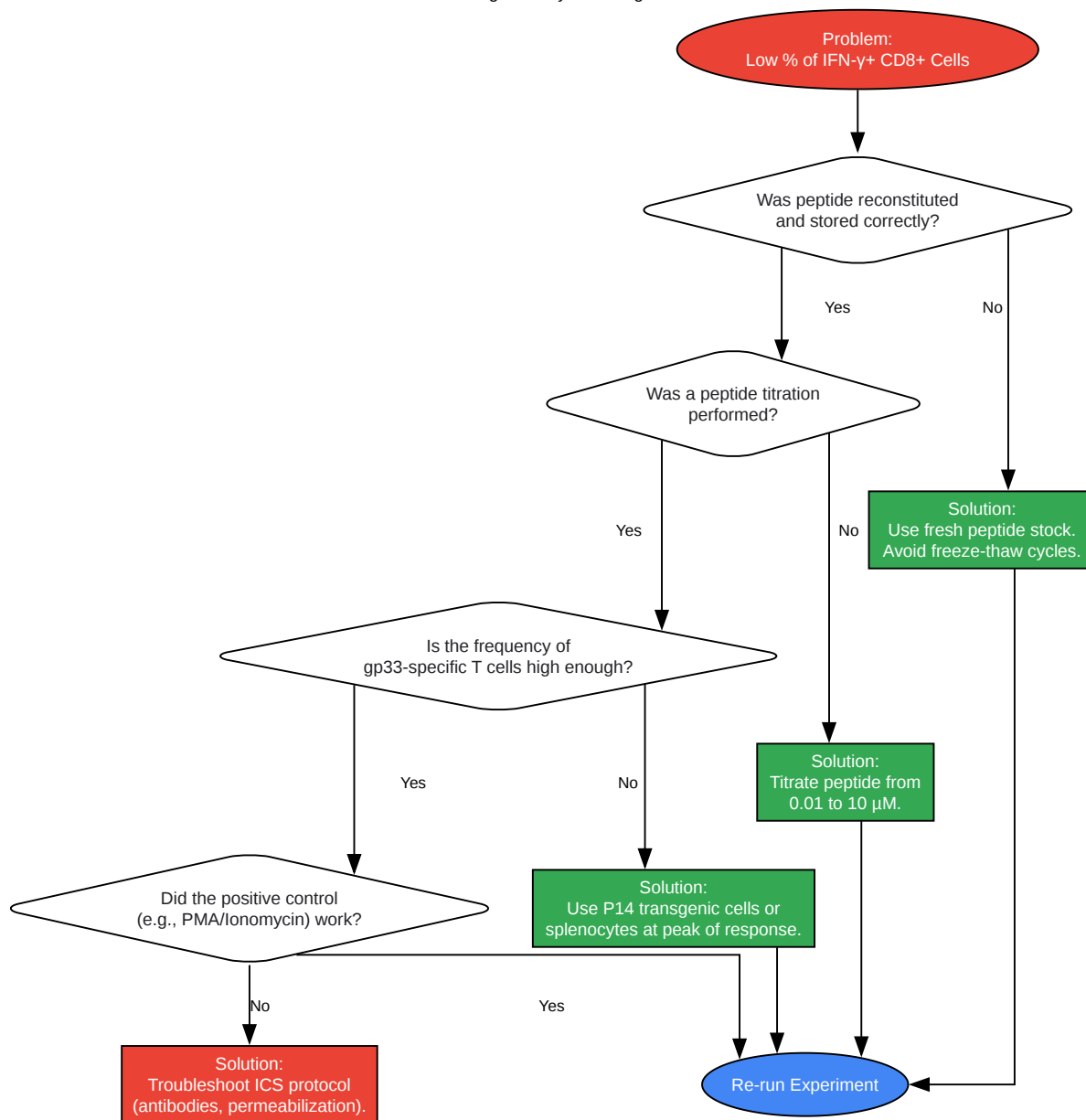

[Click to download full resolution via product page](#)

Caption: A logical guide for troubleshooting weak T cell stimulation results.

## Detailed Experimental Protocols

### Protocol: Intracellular Cytokine Staining (ICS) for gp33-41 Stimulated Splenocytes

This protocol is synthesized from standard immunology procedures.[\[10\]](#)[\[12\]](#)[\[13\]](#)[\[17\]](#)

#### I. Materials & Reagents

- Cells: Single-cell suspension of splenocytes from C57BL/6 mice (e.g., LCMV-infected or P14 TCR transgenic).
- Peptide: gp33-41 (KAVYNFATM or KAVYNFATC) stock solution (1 mM in DMSO).
- Culture Medium: Complete RPMI-1640 (supplemented with 10% FBS, L-glutamine, penicillin-streptomycin, and 2-mercaptoethanol).
- Stimulation Reagents: Brefeldin A (e.g., 5 mg/mL stock), Monensin.
- Antibodies:
  - Viability Dye (e.g., Zombie NIR™, Fixable Viability Dye eFluor™ 780).
  - Surface Staining: Anti-mouse CD8a (e.g., clone 53-6.7), Anti-mouse CD44.
  - Intracellular Staining: Anti-mouse IFN- $\gamma$  (e.g., clone XMG1.2), Anti-mouse TNF- $\alpha$  (e.g., clone MP6-XT22).
- Buffers:
  - FACS Buffer (PBS + 2% FBS + 1 mM EDTA).
  - Fixation/Permeabilization Buffer Kit (e.g., from BioLegend, eBioscience, or BD Biosciences).

#### II. Procedure

- Cell Preparation: a. Prepare a single-cell suspension of splenocytes. If necessary, lyse red blood cells with ACK lysis buffer. b. Wash cells with Culture Medium and resuspend to a final concentration of  $2 \times 10^6$  cells/mL. c. Plate  $1 \times 10^6$  cells (in 0.5 mL) per well in a 24-well or 48-well tissue culture plate.[17]
- T Cell Stimulation: a. Prepare stimulation cocktails in Culture Medium. For each well, you will need a negative control, a positive control, and your experimental condition.
  - Unstimulated Control: Add medium only.
  - gp33-41 Stimulation: Add gp33-41 peptide to a final concentration of 1  $\mu$ M (or desired concentration).
  - Positive Control: PMA (50 ng/mL) and Ionomycin (500 ng/mL).[17] b. Add the stimulation cocktails to the appropriate wells. c. Incubate for 1-2 hours at 37°C, 5% CO<sub>2</sub>. [10][17] d. Add a protein transport inhibitor (e.g., Brefeldin A to a final concentration of 10  $\mu$ g/mL) to all wells.[17] e. Incubate for an additional 4 hours at 37°C, 5% CO<sub>2</sub>.
- Surface Marker Staining: a. Harvest cells from the plates and transfer them to 5 mL FACS tubes or a 96-well V-bottom plate. b. Pellet cells by centrifugation (350 x g, 5 min) and discard the supernatant.[12] c. Wash cells once with 1-2 mL of cold FACS buffer. d. Resuspend cells in 50  $\mu$ L of FACS buffer containing the viability dye and surface antibodies (e.g., anti-CD8) at their predetermined optimal concentrations. e. Incubate for 20-30 minutes at 4°C in the dark.[13] f. Wash cells twice with 1-2 mL of cold FACS buffer.
- Fixation and Permeabilization: a. After the final wash, resuspend the cell pellet in 100-200  $\mu$ L of Fixation Buffer. b. Incubate for 20 minutes at room temperature in the dark.[12] c. Wash cells once with Permeabilization Wash Buffer. d. Pellet cells and resuspend in 100  $\mu$ L of Permeabilization Wash Buffer.
- Intracellular Staining: a. Add the intracellular antibodies (e.g., anti-IFN- $\gamma$ , anti-TNF- $\alpha$ ) at their predetermined optimal concentrations directly to the 100  $\mu$ L of cell suspension in Permeabilization Wash Buffer. b. Incubate for 30 minutes at room temperature in the dark. c. Wash cells twice with Permeabilization Wash Buffer.
- Data Acquisition: a. Resuspend the final cell pellet in 200-300  $\mu$ L of FACS Buffer. b. Acquire samples on a flow cytometer as soon as possible. If necessary, cells can be stored at 4°C in the dark for a few hours before acquisition.

- Data Analysis: a. Gate on single cells, followed by lymphocytes based on FSC-A vs. SSC-A. b. Gate on live cells using the viability dye. c. From the live cells, gate on your CD8+ T cell population. d. Analyze the expression of IFN- $\gamma$  and TNF- $\alpha$  within the CD8+ gate to determine the percentage of antigen-specific, cytokine-producing cells.

### Need Custom Synthesis?

BenchChem offers custom synthesis for rare earth carbides and specific isotopic labeling.

Email: [info@benchchem.com](mailto:info@benchchem.com) or [Request Quote Online](#).

## References

- 1. LCMV (33–41), GP33 - 1 mg [[eurogentec.com](http://eurogentec.com)]
- 2. [cmi.ustc.edu.cn](http://cmi.ustc.edu.cn) [[cmi.ustc.edu.cn](http://cmi.ustc.edu.cn)]
- 3. LCMV (33–41), GP33 - 1 mg [[anaspec.com](http://anaspec.com)]
- 4. [medchemexpress.com](http://medchemexpress.com) [[medchemexpress.com](http://medchemexpress.com)]
- 5. Frontiers | 2D Kinetic Analysis of TCR and CD8 Coreceptor for LCMV GP33 Epitopes [[frontiersin.org](http://frontiersin.org)]
- 6. [neuromics.com](http://neuromics.com) [[neuromics.com](http://neuromics.com)]
- 7. Peptide handling & storage guidelines - How to store a peptide? [[sb-peptide.com](http://sb-peptide.com)]
- 8. [journals.asm.org](http://journals.asm.org) [[journals.asm.org](http://journals.asm.org)]
- 9. Characterization of CD8 T Cell-Mediated Mutations in the Immunodominant Epitope GP33-41 of Lymphocytic Choriomeningitis Virus - PMC [[pmc.ncbi.nlm.nih.gov](http://pmc.ncbi.nlm.nih.gov)]
- 10. Multiparameter Intracellular Cytokine Staining - PMC [[pmc.ncbi.nlm.nih.gov](http://pmc.ncbi.nlm.nih.gov)]
- 11. Antigen-independent memory CD8 T cells do not develop during chronic viral infection - PMC [[pmc.ncbi.nlm.nih.gov](http://pmc.ncbi.nlm.nih.gov)]
- 12. Intracellular Flow Cytometry Staining Protocol [[protocols.io](http://protocols.io)]
- 13. [anilocus.com](http://anilocus.com) [[anilocus.com](http://anilocus.com)]
- 14. [med.virginia.edu](http://med.virginia.edu) [[med.virginia.edu](http://med.virginia.edu)]
- 15. High antigen levels induce an exhausted phenotype in a chronic infection without impairing T cell expansion and survival - PMC [[pmc.ncbi.nlm.nih.gov](http://pmc.ncbi.nlm.nih.gov)]
- 16. [medchemexpress.com](http://medchemexpress.com) [[medchemexpress.com](http://medchemexpress.com)]

- [17. cbdm.hms.harvard.edu \[cbdm.hms.harvard.edu\]](https://cbdm.hms.harvard.edu)
- To cite this document: BenchChem. [Technical Support Center: Optimizing gp33-41 Peptide Stimulation of T Cells]. BenchChem, [2026]. [Online PDF]. Available at: [<https://www.benchchem.com/product/b15605956/docs#technical-support-center-optimizing-gp33-41-peptide-stimulation-of-t-cells>]

---

### Disclaimer & Data Validity:

The information provided in this document is for Research Use Only (RUO) and is strictly not intended for diagnostic or therapeutic procedures. While BenchChem strives to provide accurate protocols, we make no warranties, express or implied, regarding the fitness of this product for every specific experimental setup.

**Technical Support:** The protocols provided are for reference purposes. Unsure if this reagent suits your experiment?

**Need Industrial/Bulk Grade?** [Request Custom Synthesis Quote](#)

## BenchChem

Our mission is to be the trusted global source of essential and advanced chemicals, empowering scientists and researchers to drive progress in science and industry.

### Contact

Address: 3281 E Guasti Rd  
Ontario, CA 91761, United States  
Phone: (601) 213-4426  
Email: [info@benchchem.com](mailto:info@benchchem.com)

[Contact our Ph.D. Support Team for a compatibility check](#)