

Technical Support Center: Mif-IN-6 & Primary Cell Cultures

Author: BenchChem Technical Support Team. **Date:** April 2026

Compound of Interest

Compound Name: *Mif-IN-6*
Cat. No.: *B15605763*

[Get Quote](#)

This technical support center provides troubleshooting guides and frequently asked questions (FAQs) for researchers, scientists, and drug development professionals encountering cytotoxicity issues with the Macrophage Migration Inhibitory Factor (MIF) inhibitor, **Mif-IN-6**, in primary cell cultures.

Frequently Asked Questions (FAQs)

Q1: What is **Mif-IN-6** and what is its mechanism of action?

Mif-IN-6 is a potent small molecule inhibitor of Macrophage Migration Inhibitory Factor (MIF).[1] [2] MIF is a pleiotropic cytokine that plays a crucial role in the regulation of the immune system, inflammation, and cell proliferation.[3] **Mif-IN-6** exerts its effects by inhibiting the tautomerase activity of MIF, which is thought to be important for its pro-inflammatory and growth-promoting functions.[4] By inhibiting MIF, **Mif-IN-6** can attenuate the activation of downstream signaling pathways such as the MAPK/ERK and PI3K/AKT pathways, which are involved in cell survival and proliferation.[2][5][6]

Q2: Why am I observing high cytotoxicity in my primary cells treated with **Mif-IN-6**?

Primary cells are often more sensitive to chemical treatments than immortalized cell lines.

Several factors can contribute to high cytotoxicity with **Mif-IN-6**:

- **On-Target Toxicity:** The MIF signaling pathway is involved in essential cellular processes, including cell survival.^{[5][6]} Inhibition of this pathway, even with a specific inhibitor, can lead to apoptosis or cell cycle arrest in healthy primary cells.
- **Off-Target Effects:** At higher concentrations, small molecule inhibitors can bind to and inhibit other cellular proteins, leading to unintended toxic effects.^{[4][7]}
- **Experimental Conditions:** Factors such as inhibitor concentration, duration of exposure, cell density, and the type of solvent used can all significantly impact cell viability.
- **Primary Cell Health:** The initial health and quality of the primary cells are critical. Stressed or unhealthy cells will be more susceptible to the cytotoxic effects of the inhibitor.
- **Solvent Toxicity:** The solvent used to dissolve **Mif-IN-6**, typically DMSO, can be toxic to some primary cells, even at low concentrations.

Q3: What is a recommended starting concentration for **Mif-IN-6** in primary cells?

The optimal concentration of **Mif-IN-6** will vary depending on the primary cell type and the specific research question. The reported IC₅₀ for **Mif-IN-6** is 1.4 μM in a cell-free assay.^{[1][2]} For primary cell culture experiments, it is crucial to perform a dose-response experiment to determine the optimal concentration. A good starting point for a dose-response curve could range from 0.1 μM to 10 μM.

Quantitative Data Summary

The following table summarizes the available quantitative data for **Mif-IN-6** and other commonly used MIF inhibitors.

Inhibitor	Target	IC50 / Ki	Notes
Mif-IN-6	MIF	IC50: 1.4 μ M, Ki: 0.96 μ M	Attenuates MIF-induced ERK phosphorylation and inhibits proliferation of A549 cells.[1][2]
ISO-1	MIF	IC50: \sim 7 μ M	A widely used reference inhibitor for MIF tautomerase activity.[4]
4-IPP	MIF	-	A specific suicide substrate and irreversible inhibitor of MIF.[1]
Iguratimod	MIF, COX-2	IC50: 6.81 μ M (MIF)	An anti-rheumatic agent that also inhibits MIF.[4]
MIF098	MIF	-	A MIF antagonist that inhibits proliferation, migration, and fibrosis of pulmonary smooth muscle cells.[1]

Signaling Pathway and Experimental Workflow

Diagrams

MIF Signaling Pathway

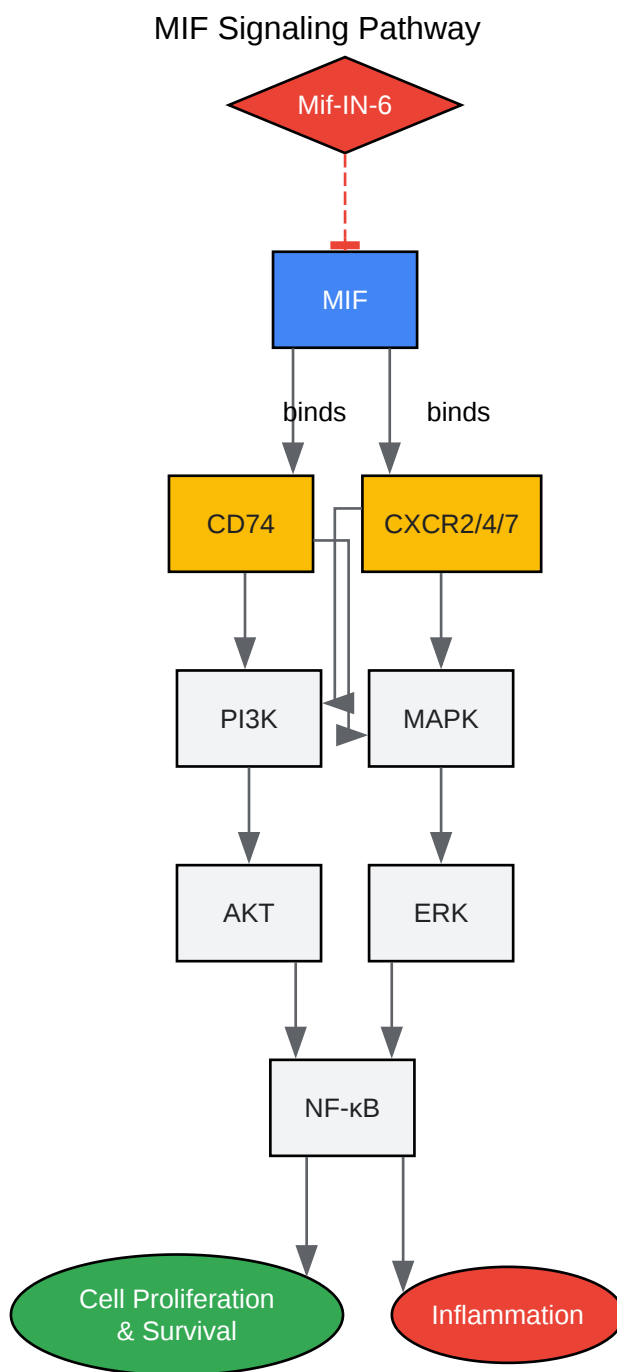

[Click to download full resolution via product page](#)

Caption: **Mif-IN-6** inhibits MIF, blocking downstream pro-survival and inflammatory signaling.

Experimental Workflow for Assessing Cytotoxicity

Cytotoxicity Assessment Workflow

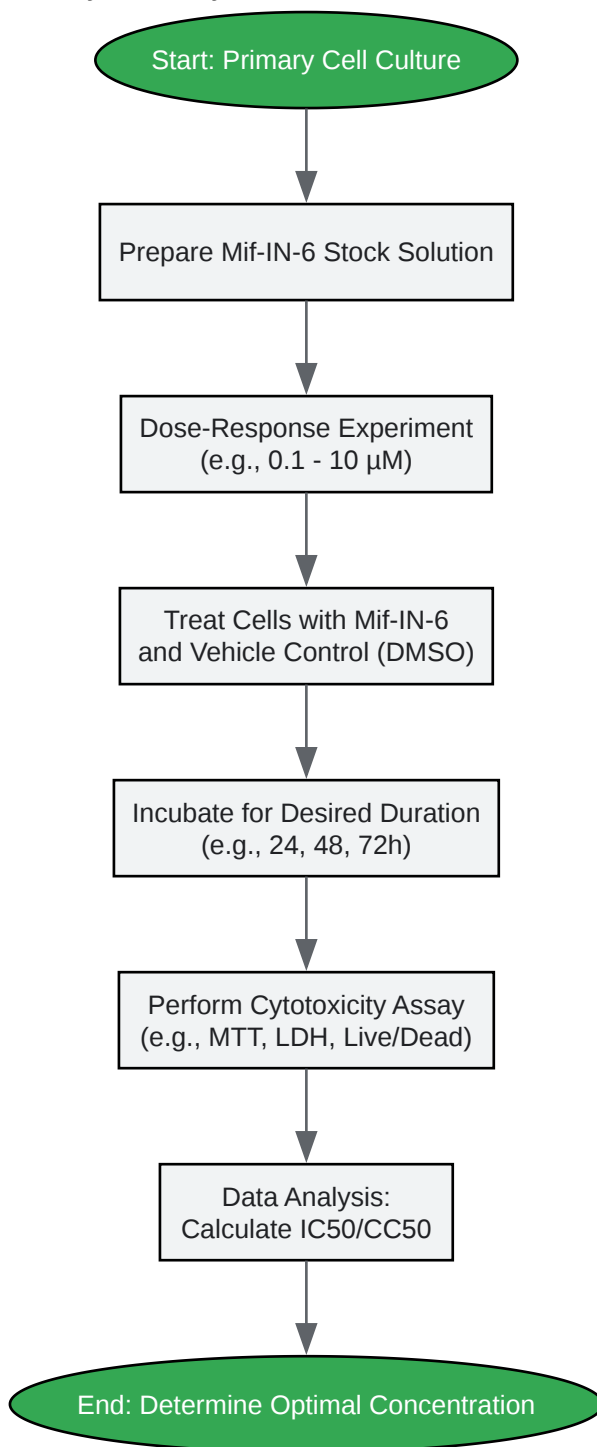

[Click to download full resolution via product page](#)

Caption: A standard workflow for determining the cytotoxic concentration of **Mif-IN-6**.

Troubleshooting Guide

Problem 1: Excessive cell death is observed even at low concentrations of **Mif-IN-6**.

- Possible Cause 1: High Sensitivity of Primary Cells.
 - Solution: Perform a comprehensive dose-response curve starting from a much lower concentration range (e.g., 10 nM to 1 μ M). Measure viability at multiple time points (e.g., 12, 24, and 48 hours) to determine the CC50 (cytotoxic concentration 50) value accurately.
- Possible Cause 2: Solvent Toxicity.
 - Solution: Ensure the final concentration of the solvent (e.g., DMSO) in the culture medium is non-toxic to your specific primary cells (ideally $\leq 0.1\%$). Run a vehicle-only control to assess the toxicity of the solvent at the highest concentration used.
- Possible Cause 3: Poor Primary Cell Health.
 - Solution: Ensure your primary cells are healthy and in the logarithmic growth phase before treatment. Use low-passage cells whenever possible and handle them gently during routine culture and plating.

Problem 2: No significant inhibitory effect is observed at any tested concentration.

- Possible Cause 1: Insufficient Inhibitor Concentration.
 - Solution: Extend the dose-response curve to higher concentrations (e.g., up to 50 μ M), while carefully monitoring for signs of cytotoxicity and insolubility.
- Possible Cause 2: Inhibitor Instability or Poor Solubility.
 - Solution: Prepare fresh stock solutions of **Mif-IN-6**. Ensure the inhibitor is fully dissolved in the solvent before diluting it in the culture medium. For long-term experiments, consider refreshing the medium with a fresh inhibitor at regular intervals.
- Possible Cause 3: Low Target Expression.

- Solution: Confirm that your primary cells express MIF at a sufficient level for the inhibitor to have a measurable effect. This can be done using techniques like Western blotting or RT-qPCR.

Troubleshooting Decision Tree



[Click to download full resolution via product page](#)

Caption: A decision tree to guide troubleshooting of common issues with **Mif-IN-6**.

Experimental Protocols

Protocol 1: Cell Viability Assessment by MTT Assay

This protocol measures cell viability based on the metabolic activity of mitochondrial dehydrogenases.

Materials:

- Primary cells
- Complete cell culture medium
- **Mif-IN-6**
- DMSO (or other appropriate solvent)
- MTT (3-(4,5-dimethylthiazol-2-yl)-2,5-diphenyltetrazolium bromide) solution (5 mg/mL in PBS)
- Solubilization solution (e.g., 10% SDS in 0.01 M HCl)
- 96-well cell culture plates

Procedure:

- **Cell Seeding:** Seed primary cells into a 96-well plate at a predetermined optimal density and allow them to adhere overnight.
- **Treatment:** Prepare serial dilutions of **Mif-IN-6** in a complete culture medium. Remove the old medium from the cells and add the medium containing the inhibitor or vehicle control (DMSO).
- **Incubation:** Incubate the plate for the desired treatment duration (e.g., 24, 48, or 72 hours).
- **MTT Addition:** Add 10 μ L of MTT solution to each well and incubate for 2-4 hours at 37°C, protected from light.

- Solubilization: Add 100 μ L of solubilization solution to each well and incubate overnight at 37°C in a humidified chamber.
- Measurement: Measure the absorbance at 570 nm using a plate reader.

Protocol 2: Cytotoxicity Assessment by LDH Release Assay

This protocol measures the release of lactate dehydrogenase (LDH) from damaged cells into the culture medium.

Materials:

- Primary cells
- Complete cell culture medium
- **Mif-IN-6**
- DMSO (or other appropriate solvent)
- LDH cytotoxicity assay kit (commercially available)
- 96-well cell culture plates

Procedure:

- Cell Seeding: Seed primary cells into a 96-well plate at an optimal density and allow them to adhere overnight.
- Treatment: Treat cells with serial dilutions of **Mif-IN-6** and a vehicle control. Include untreated cells as a negative control and a lysis control provided by the kit as a positive control for maximum LDH release.
- Incubation: Incubate the plate for the desired treatment duration.
- Sample Collection: Carefully collect a portion of the supernatant from each well without disturbing the cells.

- LDH Assay: Perform the LDH assay on the collected supernatants according to the manufacturer's instructions.
- Measurement: Measure the absorbance at the recommended wavelength using a plate reader.
- Calculation: Calculate the percentage of cytotoxicity based on the absorbance values of the treated, negative control, and positive control wells.

Need Custom Synthesis?

BenchChem offers custom synthesis for rare earth carbides and specific isotopic labeling.

Email: info@benchchem.com or [Request Quote Online](#).

References

- [1. medchemexpress.com \[medchemexpress.com\]](https://www.medchemexpress.com)
- [2. medchemexpress.com \[medchemexpress.com\]](https://www.medchemexpress.com)
- [3. What are MIF inhibitors and how do they work? \[synapse.patsnap.com\]](https://synapse.patsnap.com)
- [4. Small molecule inhibitors of macrophage migration inhibitory factor \(MIF\) as emerging class of therapeutics for immune disorders - PMC \[pmc.ncbi.nlm.nih.gov\]](https://pubmed.ncbi.nlm.nih.gov)
- [5. researchgate.net \[researchgate.net\]](https://www.researchgate.net)
- [6. cellphysiolbiochem.com \[cellphysiolbiochem.com\]](https://www.cellphysiolbiochem.com)
- [7. What MIF inhibitors are in clinical trials currently? \[synapse.patsnap.com\]](https://synapse.patsnap.com)
- To cite this document: BenchChem. [Technical Support Center: Mif-IN-6 & Primary Cell Cultures]. BenchChem, [2026]. [Online PDF]. Available at: [\[https://www.benchchem.com/product/b15605763/docs#technical-support-center-mif-in-6-primary-cell-cultures\]](https://www.benchchem.com/product/b15605763/docs#technical-support-center-mif-in-6-primary-cell-cultures)

Disclaimer & Data Validity:

The information provided in this document is for Research Use Only (RUO) and is strictly not intended for diagnostic or therapeutic procedures. While BenchChem strives to provide

accurate protocols, we make no warranties, express or implied, regarding the fitness of this product for every specific experimental setup.

Technical Support: The protocols provided are for reference purposes. Unsure if this reagent suits your experiment?

Need Industrial/Bulk Grade? [Request Custom Synthesis Quote](#)

BenchChem

Our mission is to be the trusted global source of essential and advanced chemicals, empowering scientists and researchers to drive progress in science and industry.

Contact

Address: 3281 E Guasti Rd

Ontario, CA 91761, United States

Phone: (601) 213-4426

Email: info@benchchem.com

[Contact our Ph.D. Support Team for a compatibility check](#)