

# Preliminary In-Vitro Profile of MPC-1304: A Technical Overview

**Author:** BenchChem Technical Support Team. **Date:** April 2026

## Compound of Interest

Compound Name: YOK-1304

Cat. No.: B15605711

[Get Quote](#)

For distribution to: Researchers, Scientists, and Drug Development Professionals.

This technical guide provides a comprehensive summary of the preliminary in-vitro studies conducted on MPC-1304, a novel dihydropyridine calcium channel antagonist. The information presented herein is synthesized from publicly available scientific literature and is intended to provide a detailed understanding of the compound's mechanism of action, potency, and pharmacological profile at the cellular and tissue level.

## Core Mechanism of Action

MPC-1304 is a potent L-type calcium channel blocker. Its primary pharmacological effect is the inhibition of calcium ion influx into vascular smooth muscle and cardiac cells, leading to vasodilation and negative chronotropic and inotropic effects.

## Quantitative In-Vitro Data

The following tables summarize the key quantitative findings from in-vitro studies of MPC-1304.

## Table 1: Calcium Entry Blocking Activity in Isolated Rabbit Arteries

Compound	Relative Potency (vs. (R)-enantiomer)
(S)-enantiomer of MPC-1304	~150x more potent[1]
(R)-enantiomer of MPC-1304	Baseline

## Table 2: Electrophysiological Effects on L-type Ca<sup>2+</sup> Channels in Guinea-Pig Hearts

Parameter	Value
Dissociation Constant (Resting State)	137.7 nM[2]
Dissociation Constant (Inactivated State)	49.9 nM[2]
Tonic Block (at 100 nM)	29.5% depression of I(Ca)[2]
Use-Dependent Block (1 Hz at 100 nM)	25.5% depression of I(Ca)[2]
Use-Dependent Block (2 Hz at 100 nM)	34.0% depression of I(Ca)[2]

## Table 3: Cardiovascular Effects in Isolated Guinea-Pig Atria

Parameter	Observation
Negative Chronotropic/Inotropic Effect Ratio	23 times higher than nifedipine[3]

## Experimental Protocols

The following are detailed methodologies for the key in-vitro experiments cited in this guide. These protocols are based on the information available in the abstracts of the referenced studies and have been supplemented with standard laboratory practices for these types of assays.

## Ca<sup>2+</sup>-Induced Contraction in Isolated Rabbit Arteries

This assay evaluates the ability of a compound to inhibit vascular smooth muscle contraction induced by an influx of extracellular calcium.

Protocol:

- **Tissue Preparation:** Male rabbits are euthanized, and the thoracic aorta or other suitable arteries are excised and placed in a cold, oxygenated physiological salt solution (PSS). The arteries are cleaned of adhering connective tissue and cut into helical strips or rings.
- **Mounting:** The arterial preparations are mounted in an organ bath containing a PSS, maintained at 37°C, and continuously bubbled with a 95% O<sub>2</sub> / 5% CO<sub>2</sub> gas mixture. One end of the preparation is fixed, and the other is connected to an isometric force transducer to record changes in tension.
- **Equilibration:** The preparations are allowed to equilibrate for a period of 60-90 minutes under a resting tension. During this time, the PSS is changed every 15-20 minutes.
- **Depolarization:** The tissues are exposed to a high-potassium, calcium-free PSS to depolarize the cell membranes.
- **Ca<sup>2+</sup>-Induced Contraction:** Cumulative concentrations of CaCl<sub>2</sub> are added to the organ bath to induce concentration-dependent contractions.
- **Compound Incubation:** After washing out the initial CaCl<sub>2</sub>-induced contractions, the arterial preparations are incubated with MPC-1304 (or its enantiomers/metabolites) for a predetermined period.
- **Inhibitory Effect Measurement:** The cumulative concentration-response curve to CaCl<sub>2</sub> is repeated in the presence of the test compound. The inhibitory effect is quantified by the rightward shift of the concentration-response curve and the reduction in the maximum contraction. IC<sub>50</sub> values are then calculated.

## Whole-Cell Patch-Clamp Electrophysiology in Guinea-Pig Cardiomyocytes

This technique is used to measure the effect of MPC-1304 on the L-type Ca<sup>2+</sup> current (I(Ca)) in isolated heart cells.

#### Protocol:

- **Cell Isolation:** Single ventricular myocytes are isolated from guinea-pig hearts by enzymatic digestion.
- **Patch-Clamp Recording:** The whole-cell patch-clamp technique is employed. A glass micropipette with a tip diameter of  $\sim 1 \mu\text{m}$  is used to form a high-resistance seal with the cell membrane. The membrane patch under the pipette tip is then ruptured to gain electrical access to the cell interior.
- **Voltage Clamp:** The cell membrane potential is clamped at a holding potential (e.g.,  $-80 \text{ mV}$ ). Depolarizing voltage steps are applied to elicit the L-type  $\text{Ca}^{2+}$  current.
- **Drug Application:** MPC-1304 is applied to the cell via the extracellular perfusion solution at various concentrations.
- **Data Acquisition and Analysis:** The effects of MPC-1304 on the amplitude and kinetics of the  $I(\text{Ca})$  are recorded.
  - **Tonic Block:** The reduction in the current amplitude during the first depolarizing pulse after drug application.
  - **Use-Dependent Block:** The progressive reduction in current amplitude during a train of depolarizing pulses at different frequencies.
  - **Steady-State Inactivation:** The voltage-dependence of channel availability is assessed by applying a series of pre-pulses to different potentials before a test pulse.

## Signaling Pathways and Experimental Workflows

The following diagrams illustrate the proposed signaling pathway for MPC-1304 and the general workflow of the key in-vitro experiments.

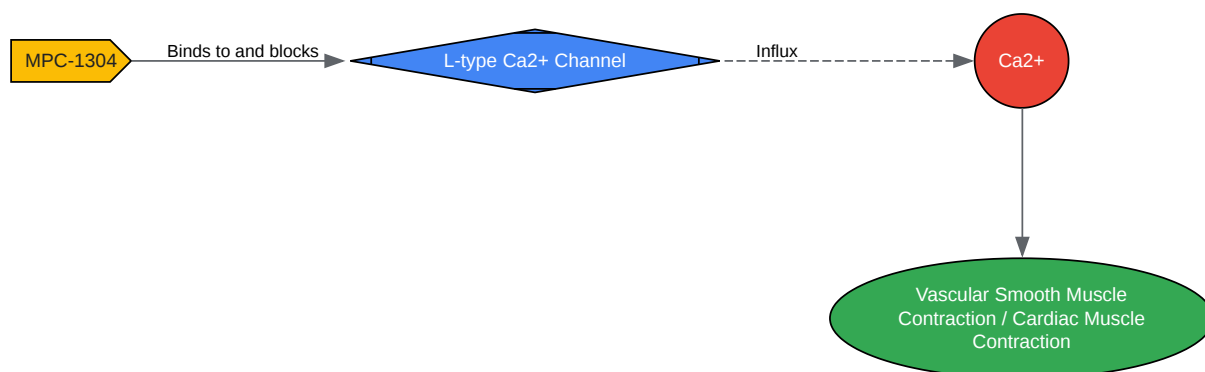

[Click to download full resolution via product page](#)

Caption: Proposed mechanism of action for MPC-1304.

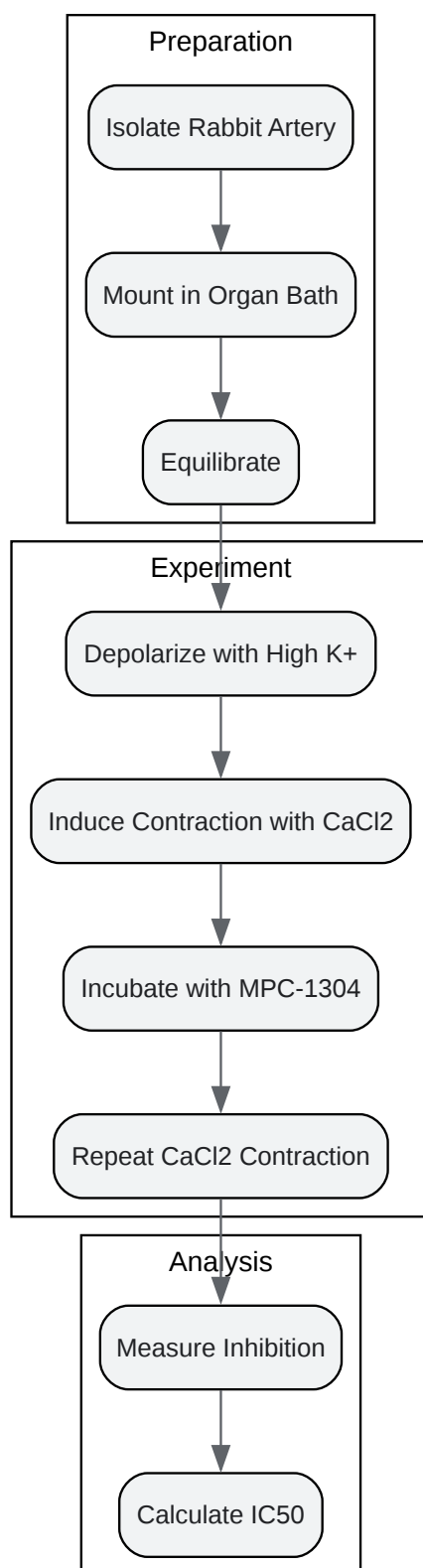

[Click to download full resolution via product page](#)

Caption: Experimental workflow for the Ca<sup>2+</sup>-induced contraction assay.

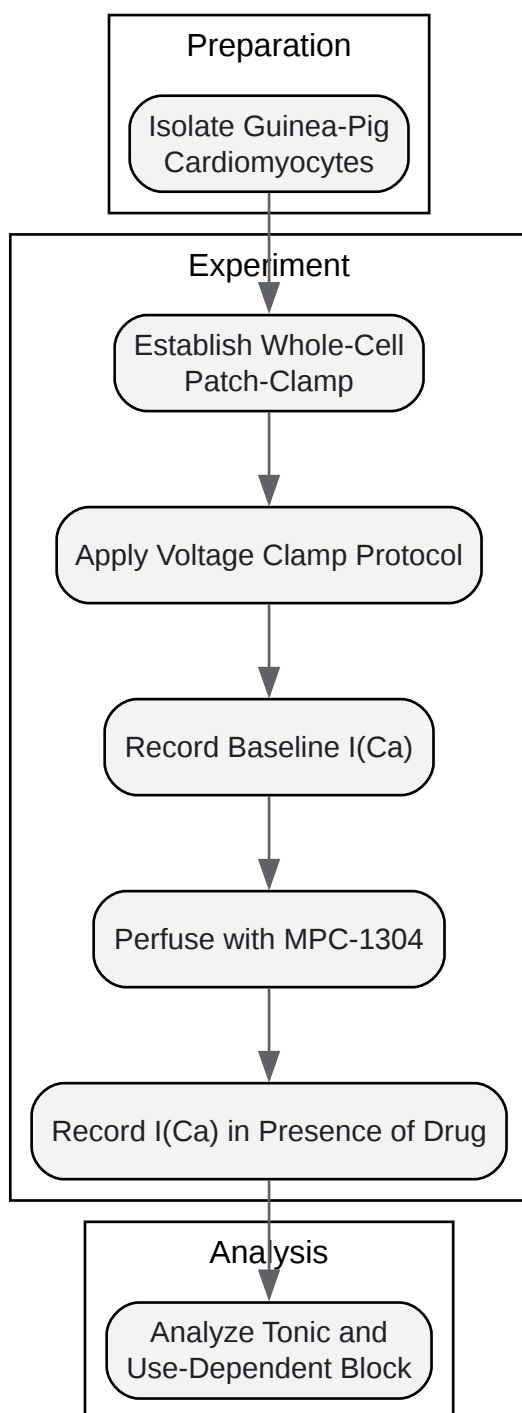

[Click to download full resolution via product page](#)

Caption: Experimental workflow for whole-cell patch-clamp electrophysiology.

### Need Custom Synthesis?

BenchChem offers custom synthesis for rare earth carbides and specific isotopic labeling.

Email: [info@benchchem.com](mailto:info@benchchem.com) or [Request Quote Online](#).

## References

- 1. Calcium entry blocking activities of MPC-1304 and of its enantiomers and metabolites - PubMed [[pubmed.ncbi.nlm.nih.gov](https://pubmed.ncbi.nlm.nih.gov)]
- 2. Voltage- and frequency-dependent modulation of L-type Ca<sup>2+</sup> channel by MPC-1304, a novel calcium antagonist in guinea-pig hearts - PubMed [[pubmed.ncbi.nlm.nih.gov](https://pubmed.ncbi.nlm.nih.gov)]
- 3. Cardiovascular profile of MPC-1304, a novel dihydropyridine calcium antagonist: comparison with other calcium antagonists - PubMed [[pubmed.ncbi.nlm.nih.gov](https://pubmed.ncbi.nlm.nih.gov)]
- To cite this document: BenchChem. [Preliminary In-Vitro Profile of MPC-1304: A Technical Overview]. BenchChem, [2026]. [Online PDF]. Available at: [<https://www.benchchem.com/product/b15605711/docs#preliminary-in-vitro-profile-of-mpc-1304-a-technical-overview>]

---

### Disclaimer & Data Validity:

The information provided in this document is for Research Use Only (RUO) and is strictly not intended for diagnostic or therapeutic procedures. While BenchChem strives to provide accurate protocols, we make no warranties, express or implied, regarding the fitness of this product for every specific experimental setup.

**Technical Support:** The protocols provided are for reference purposes. Unsure if this reagent suits your experiment?

**Need Industrial/Bulk Grade?** [Request Custom Synthesis Quote](#)

# BenchChem

Our mission is to be the trusted global source of essential and advanced chemicals, empowering scientists and researchers to drive progress in science and industry.

## Contact

Address: 3281 E Guasti Rd

Ontario, CA 91761, United States

Phone: (601) 213-4426

Email: [info@benchchem.com](mailto:info@benchchem.com)

[Contact our Ph.D. Support Team for a compatibility check](#)