

Nms-P715: Application Notes and Protocols for Cell-Based Assays

Author: BenchChem Technical Support Team. **Date:** April 2026

Compound of Interest

Compound Name: Nms-P715

Cat. No.: B15605276

[Get Quote](#)

For Researchers, Scientists, and Drug Development Professionals

Introduction

Nms-P715 is a potent and selective small-molecule inhibitor of Monopolar Spindle 1 (MPS1) kinase, a critical regulator of the spindle assembly checkpoint (SAC).[1][2][3] The SAC is a crucial cellular mechanism that ensures proper chromosome segregation during mitosis.[2][3] In many cancer cells, which often exhibit aneuploidy and are highly proliferative, the SAC is aberrantly overexpressed, making it a promising therapeutic target.[2][4][5] **Nms-P715** disrupts the SAC, leading to mitotic catastrophe, G2/M cell cycle arrest, aneuploidy, and ultimately, caspase-dependent apoptosis in various cancer cell lines.[1][2] These application notes provide detailed protocols for investigating the cellular effects of **Nms-P715** in vitro.

Mechanism of Action

Nms-P715 functions as an ATP-competitive inhibitor of MPS1 kinase.[6] By inhibiting MPS1, **Nms-P715** prevents the recruitment of essential checkpoint proteins to the kinetochores of unattached chromosomes. This leads to a premature exit from mitosis, resulting in severe chromosomal mis-segregation and the induction of apoptosis. This targeted action makes

Nms-P715 a subject of interest for cancer therapy, particularly in tumors with high mitotic rates and dependency on the spindle assembly checkpoint.

Data Presentation

In Vitro Activity of Nms-P715

Parameter	Cell Line	Value	Reference
IC50 (MPS1 Kinase Assay)	-	182 nM	[6][7]
EC50 (SAC Override)	U2OS	65 nM	[7]
IC50 (Proliferation)	HCT116	Not Specified	[7]
BxPC-3 (PDAC)	< 1 μ M	[8]	
PANC-1 (PDAC)	~5 μ M	[8]	
Daoy (Medulloblastoma)	Dose-dependent	[5]	
ONS-76 (Medulloblastoma)	Dose-dependent	[5]	
Apoptosis Induction	KKU-213A (CCA)	Caspase 3 activation	[1]
PDAC cell lines	Annexin V positive	[8]	
Medulloblastoma cell lines	Annexin V positive	[5]	
Cell Cycle Arrest	CCA cell lines	G2/M arrest	[1]
Medulloblastoma cell lines	G2/M arrest	[5]	

Experimental Protocols

Cell Viability and Proliferation Assay (MTT Assay)

This protocol is designed to assess the effect of **Nms-P715** on cancer cell viability and proliferation.

Materials:

- Cancer cell lines of interest (e.g., HCT116, BxPC-3, PANC-1)
- Complete culture medium (e.g., DMEM, McCoy's 5A) with 10% Fetal Bovine Serum (FBS)
- **Nms-P715** (dissolved in DMSO)
- 96-well plates
- MTT (3-(4,5-dimethylthiazol-2-yl)-2,5-diphenyltetrazolium bromide) solution (5 mg/mL in PBS)
- Solubilization solution (e.g., DMSO or 10% SDS in 0.01 M HCl)
- Microplate reader

Procedure:

- Cell Seeding:
 - Trypsinize and count the cells.
 - Seed 5,000-10,000 cells per well in a 96-well plate in 100 μ L of complete culture medium.
 - Incubate overnight at 37°C in a humidified 5% CO₂ incubator to allow for cell attachment.
- Compound Treatment:
 - Prepare serial dilutions of **Nms-P715** in complete culture medium. It is recommended to maintain a final DMSO concentration of less than 0.1% to avoid solvent-induced cytotoxicity.^[7]
 - Carefully remove the medium from the wells and replace it with 100 μ L of the medium containing the desired concentrations of **Nms-P715**. Include a vehicle control (DMSO) and an untreated control.
 - Incubate for the desired treatment duration (e.g., 24, 48, or 72 hours).^[7]

- MTT Addition and Incubation:
 - After the incubation period, add 10 μ L of MTT solution (5 mg/mL) to each well.[9]
 - Incubate the plate for 2-4 hours at 37°C, allowing viable cells to metabolize the MTT into formazan crystals.[9]
- Solubilization and Measurement:
 - Carefully remove the medium containing MTT.
 - Add 100 μ L of solubilization solution to each well to dissolve the formazan crystals.[9]
 - Gently mix the contents of the wells on a plate shaker for 15 minutes to ensure complete solubilization.
 - Measure the absorbance at 570 nm using a microplate reader.[10]
- Data Analysis:
 - Calculate the percentage of cell viability relative to the untreated control.
 - Plot the percentage of viability against the log concentration of **Nms-P715** to determine the IC50 value using a non-linear regression curve fit.

Cell Cycle Analysis by Flow Cytometry

This protocol allows for the determination of the cell cycle distribution of cells treated with **Nms-P715**.

Materials:

- Cancer cell lines
- Complete culture medium
- **Nms-P715** (dissolved in DMSO)
- 6-well plates

- Phosphate-Buffered Saline (PBS)
- 70% Ethanol (ice-cold)
- Propidium Iodide (PI) staining solution (containing RNase A)
- Flow cytometer

Procedure:

- Cell Seeding and Treatment:
 - Seed approximately $1-2 \times 10^5$ cells per well in 6-well plates.
 - Allow cells to attach overnight.
 - Treat cells with various concentrations of **Nms-P715** (e.g., 0.1, 1, 10 μ M) and a vehicle control for 24-48 hours.
- Cell Harvesting and Fixation:
 - Harvest both adherent and floating cells.
 - Wash the cells twice with ice-cold PBS.[\[11\]](#)
 - Resuspend the cell pellet in 500 μ L of ice-cold PBS.
 - While gently vortexing, add 4.5 mL of ice-cold 70% ethanol dropwise to fix the cells.[\[11\]](#)
 - Incubate the cells at 4°C for at least 2 hours (or overnight).[\[11\]](#)
- Staining and Analysis:
 - Centrifuge the fixed cells and discard the ethanol.
 - Wash the cells once with PBS.
 - Resuspend the cell pellet in PI staining solution.

- Incubate for 30 minutes at room temperature in the dark.
- Analyze the samples using a flow cytometer.
- Data Analysis:
 - Use appropriate software to analyze the cell cycle distribution based on DNA content (G1, S, G2/M phases).

Apoptosis Assay by Annexin V/PI Staining

This protocol quantifies the percentage of apoptotic and necrotic cells following **Nms-P715** treatment.

Materials:

- Cancer cell lines
- Complete culture medium
- **Nms-P715** (dissolved in DMSO)
- 6-well plates
- Annexin V-FITC Apoptosis Detection Kit (containing Annexin V-FITC, Propidium Iodide, and Binding Buffer)
- Flow cytometer

Procedure:

- Cell Seeding and Treatment:
 - Seed cells in 6-well plates and treat with **Nms-P715** as described in the cell cycle analysis protocol.
- Cell Harvesting:
 - Collect both adherent and floating cells.

- Wash the cells twice with cold PBS.[12]
- Staining:
 - Resuspend the cell pellet in 1X Binding Buffer at a concentration of 1×10^6 cells/mL.[12]
 - Transfer 100 μ L of the cell suspension to a flow cytometry tube.[12]
 - Add 5 μ L of Annexin V-FITC and 5 μ L of Propidium Iodide.[11][12]
 - Gently vortex and incubate for 15 minutes at room temperature in the dark.[11][12]
- Flow Cytometry Analysis:
 - Add 400 μ L of 1X Binding Buffer to each tube.[12]
 - Analyze the samples by flow cytometry within one hour.[11][12]
- Data Analysis:
 - Quantify the percentage of cells in each quadrant:
 - Annexin V- / PI- (Live cells)
 - Annexin V+ / PI- (Early apoptotic cells)
 - Annexin V+ / PI+ (Late apoptotic/necrotic cells)
 - Annexin V- / PI+ (Necrotic cells)

Western Blotting for Protein Expression Analysis

This protocol is used to detect changes in the expression of key proteins involved in the cell cycle and apoptosis upon **Nms-P715** treatment.

Materials:

- Cancer cell lines

- Complete culture medium
- **Nms-P715** (dissolved in DMSO)
- 6-well plates or larger culture dishes
- RIPA lysis buffer with protease and phosphatase inhibitors
- BCA Protein Assay Kit
- Laemmli sample buffer
- SDS-PAGE gels
- Transfer buffer
- PVDF or nitrocellulose membranes
- Blocking buffer (e.g., 5% non-fat milk or BSA in TBST)
- Primary antibodies (e.g., anti-Cyclin B1, anti-CDC2, anti-cleaved Caspase-3, anti-pS10H3, anti- β -actin)
- HRP-conjugated secondary antibodies
- Enhanced Chemiluminescence (ECL) substrate
- Imaging system (e.g., ChemiDoc)

Procedure:

- Cell Lysis and Protein Quantification:
 - Seed and treat cells with **Nms-P715** as previously described.
 - Wash cells with ice-cold PBS and lyse them in RIPA buffer.[\[13\]](#)[\[14\]](#)
 - Scrape the cells and collect the lysate.[\[13\]](#)[\[14\]](#)

- Centrifuge the lysate to pellet cell debris and collect the supernatant.[13][14]
- Determine the protein concentration of each lysate using a BCA assay.
- Sample Preparation and SDS-PAGE:
 - Normalize the protein concentrations for all samples.
 - Add Laemmli sample buffer and boil the samples at 95-100°C for 5 minutes.[13][14]
 - Load equal amounts of protein (e.g., 20-30 µg) into the wells of an SDS-PAGE gel.
 - Run the gel to separate the proteins by size.
- Protein Transfer:
 - Transfer the separated proteins from the gel to a PVDF or nitrocellulose membrane using a wet or semi-dry transfer system.[15][16]
- Immunoblotting:
 - Block the membrane with blocking buffer for 1 hour at room temperature to prevent non-specific antibody binding.[14][17]
 - Incubate the membrane with the primary antibody (diluted in blocking buffer) overnight at 4°C with gentle agitation.[14][17]
 - Wash the membrane three times with TBST for 5-10 minutes each.[17]
 - Incubate the membrane with the HRP-conjugated secondary antibody (diluted in blocking buffer) for 1 hour at room temperature.[14][17]
 - Wash the membrane again three times with TBST.
- Detection:
 - Incubate the membrane with ECL substrate according to the manufacturer's instructions.
[16]

- Capture the chemiluminescent signal using an imaging system.
- Data Analysis:
 - Analyze the band intensities using appropriate software. Normalize the expression of the protein of interest to a loading control (e.g., β -actin).

Visualizations

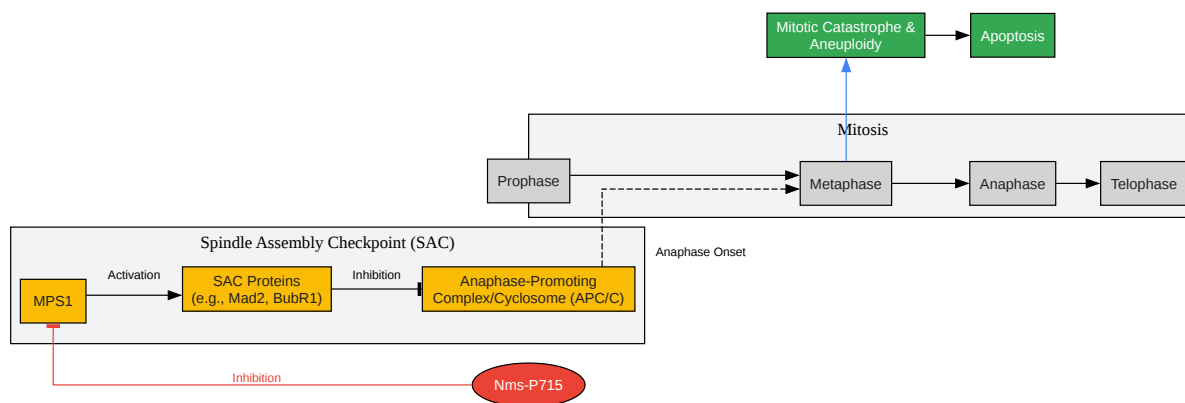

[Click to download full resolution via product page](#)

Caption: **Nms-P715** inhibits MPS1, leading to SAC abrogation and apoptosis.

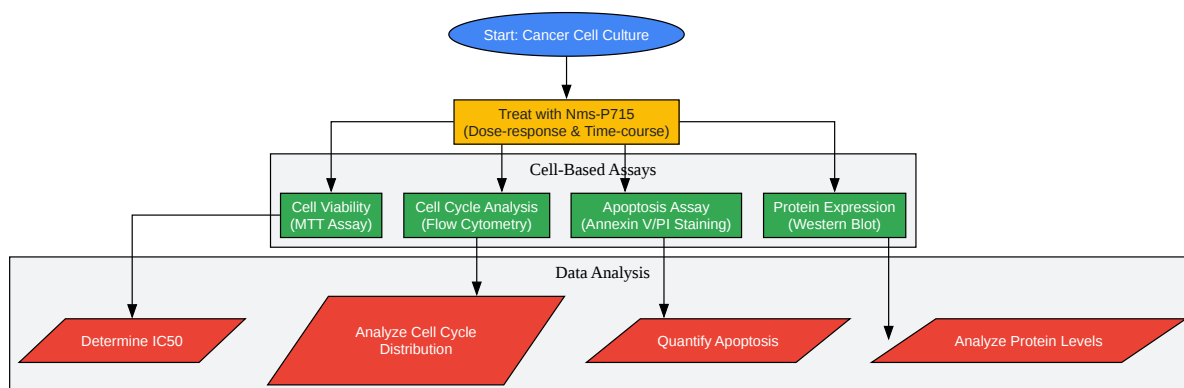

[Click to download full resolution via product page](#)

Caption: Workflow for evaluating the in vitro effects of **Nms-P715**.

Need Custom Synthesis?

BenchChem offers custom synthesis for rare earth carbides and specific isotopic labeling.

Email: info@benchchem.com or [Request Quote Online](#).

References

- 1. [researchgate.net](https://www.researchgate.net) [researchgate.net]
- 2. Targeting the mitotic checkpoint for cancer therapy with NMS-P715, an inhibitor of MPS1 kinase - PubMed [pubmed.ncbi.nlm.nih.gov]
- 3. [PDF] Targeting the mitotic checkpoint for cancer therapy with NMS-P715, an inhibitor of MPS1 kinase. | Semantic Scholar [semanticscholar.org]

- [4. Selective inhibition of pancreatic ductal adenocarcinoma cell growth by the mitotic MPS1 kinase inhibitor NMS-P715 - PubMed \[pubmed.ncbi.nlm.nih.gov\]](#)
- [5. spandidos-publications.com \[spandidos-publications.com\]](#)
- [6. medchemexpress.com \[medchemexpress.com\]](#)
- [7. file.medchemexpress.com \[file.medchemexpress.com\]](#)
- [8. aacrjournals.org \[aacrjournals.org\]](#)
- [9. researchgate.net \[researchgate.net\]](#)
- [10. Cell Viability Assays - Assay Guidance Manual - NCBI Bookshelf \[ncbi.nlm.nih.gov\]](#)
- [11. Protocols | Flow Cytometry Core Facility \[flow.sdsu.edu\]](#)
- [12. benchchem.com \[benchchem.com\]](#)
- [13. bio-rad.com \[bio-rad.com\]](#)
- [14. cdn.technologynetworks.com \[cdn.technologynetworks.com\]](#)
- [15. nacalai.com \[nacalai.com\]](#)
- [16. documents.thermofisher.com \[documents.thermofisher.com\]](#)
- [17. 7tmantibodies.com \[7tmantibodies.com\]](#)
- To cite this document: BenchChem. [Nms-P715: Application Notes and Protocols for Cell-Based Assays]. BenchChem, [2026]. [Online PDF]. Available at: [\[https://www.benchchem.com/product/b15605276/docs#nms-p715-application-notes-and-protocols-for-cell-based-assays\]](https://www.benchchem.com/product/b15605276/docs#nms-p715-application-notes-and-protocols-for-cell-based-assays)

Disclaimer & Data Validity:

The information provided in this document is for Research Use Only (RUO) and is strictly not intended for diagnostic or therapeutic procedures. While BenchChem strives to provide accurate protocols, we make no warranties, express or implied, regarding the fitness of this product for every specific experimental setup.

Technical Support: The protocols provided are for reference purposes. Unsure if this reagent suits your experiment?

Need Industrial/Bulk Grade? [Request Custom Synthesis Quote](#)

BenchChem

Our mission is to be the trusted global source of essential and advanced chemicals, empowering scientists and researchers to drive progress in science and industry.

Contact

Address: 3281 E Guasti Rd
Ontario, CA 91761, United States
Phone: (601) 213-4426
Email: info@benchchem.com

[Contact our Ph.D. Support Team for a compatibility check](#)