

# Navigating Fuzapladib Sodium Research: A Guide to Consistent Results

**Author:** BenchChem Technical Support Team. **Date:** April 2026

## Compound of Interest

Compound Name: *Fuzapladib sodium*

Cat. No.: *B15605571*

[Get Quote](#)

## Technical Support Center

Welcome to the technical support center for **Fuzapladib sodium** studies. This resource is designed for researchers, scientists, and drug development professionals to address common challenges and inconsistencies encountered during experimentation. Here, you will find troubleshooting guides and frequently asked questions (FAQs) to help ensure the reliability and reproducibility of your results.

## Frequently Asked Questions (FAQs)

Q1: What is the primary mechanism of action for **Fuzapladib sodium**?

A1: **Fuzapladib sodium** is a novel leukocyte function-associated antigen-1 (LFA-1) activation inhibitor.[1][2][3] It works by blocking the activation of LFA-1 on neutrophils, which in turn prevents their adhesion to vascular endothelium and subsequent extravasation into tissues.[1][4] This inhibition of neutrophil migration is key to reducing inflammation, particularly in conditions like acute pancreatitis.[4][5] While initially developed as a potent phospholipase A2 (PLA2) inhibitor, its role as an LFA-1 inhibitor is now the recognized mechanism.[6]

Q2: What is the approved indication for **Fuzapladib sodium**?

A2: **Fuzapladib sodium**, under the trade name PANOQUELL®-CA1, has received conditional approval from the U.S. Food and Drug Administration (FDA) for the management of clinical signs associated with the acute onset of pancreatitis in dogs.[1][3][7] It is intended to be used in conjunction with standard supportive care.[7] In Japan, it has been approved since 2018 for improving clinical signs in the acute phase of pancreatitis in dogs.[3][8]

Q3: Are there known species-specific differences in the pharmacokinetics of **Fuzapladib sodium**?

A3: Yes, significant species-specific differences in the pharmacokinetic properties of **Fuzapladib sodium** have been observed between rats, cats, and dogs. A study demonstrated notable variations in clearance rates after intravenous administration, with dogs showing the slowest clearance.[6][9] These differences suggest that dosing regimens may need to be adjusted accordingly for different species.[6]

## Troubleshooting Inconsistent Experimental Results

### Issue 1: High Variability in Clinical Efficacy

Researchers may observe significant variability in the clinical improvement of subjects treated with **Fuzapladib sodium**.

Possible Causes and Solutions:

- Inconsistent Disease Severity at Baseline: The efficacy of **Fuzapladib sodium** can be influenced by the severity of pancreatitis at the time of treatment initiation. Studies have shown that the goal of the treatment is to prevent the progression to severe disease.[10]
  - Recommendation: Standardize inclusion criteria to enroll subjects with a consistent and well-defined disease severity. Utilize a validated clinical scoring system, such as the Modified Canine Activity Index (MCAI), to quantify baseline severity.[2][7]
- Variations in Supportive Care: **Fuzapladib sodium** is intended for use with standard supportive care.[7] Inconsistencies in fluid therapy, analgesia, and nutritional support can impact overall outcomes.

- Recommendation: Implement a standardized and detailed supportive care protocol for all study groups to minimize variability.
- Underlying Comorbidities: The presence of concurrent conditions such as cardiac disease, hepatic failure, or renal impairment has not been evaluated and could affect the drug's efficacy and safety profile.[\[4\]](#)[\[7\]](#)
  - Recommendation: Carefully screen subjects for comorbidities and consider them as exclusion criteria or stratify the analysis based on their presence.

## Issue 2: Discrepancies in Biomarker Levels

Studies may yield inconsistent results regarding the effect of **Fuzapladib sodium** on inflammatory biomarkers.

Possible Causes and Solutions:

- Timing of Sample Collection: The kinetics of inflammatory biomarkers can vary. A randomized, masked, and placebo-controlled multicenter study found no significant difference in secondary variables, including canine pancreatic lipase immunoreactivity and C-reactive protein, between fuzapladib-treated and placebo groups.[\[2\]](#)[\[11\]](#)
  - Recommendation: Establish a strict and consistent schedule for blood sample collection at multiple time points to capture the dynamic changes in biomarker levels throughout the treatment course.
- Assay Variability: Different assay kits and methodologies for measuring biomarkers like canine pancreatic lipase immunoreactivity (cPLI) can produce different results.
  - Recommendation: Use a single, validated assay method and kit for all samples within a study to ensure consistency.

## Data Presentation

Table 1: Summary of Clinical Efficacy from a Pilot Field Study

Group	N	Mean Change in MCAI Score (Day 0 to Day 3)	P-value
Fuzapladib Sodium	17	-7.7	0.0193
Vehicle Control	19	-5.7	

Data from a pilot field study for the conditional approval of PANOQUELL®-CA1. A statistically significant reduction in the Modified Canine Activity Index (MCAI) score was observed in dogs treated with **fuzapladib sodium** compared to the control group.[12][13]

Table 2: Pharmacokinetic Parameters of **Fuzapladib Sodium** in Different Species (Intravenous Administration)

Species	Sex	Clearance (CL <sub>tot</sub> ) (mL/h.kg)
Rats	Male	687 ± 24
	Female	730 ± 110
Cats	Male	74 ± 11
	Female	55 ± 4.7
Dogs	Male	16 ± 2
	Female	19 ± 2.9

Values are expressed as means ± SE. Data highlights the significant inter-species differences in the clearance of **Fuzapladib sodium**.[9]

## Experimental Protocols

Protocol 1: Administration of **Fuzapladib Sodium** in a Canine Model of Acute Pancreatitis

This protocol is based on the dosage used in the pilot field study for the conditional FDA approval.

- Reconstitution:
  - The lyophilized powder of **Fuzapladib sodium** (PANOQUELL®-CA1) is reconstituted with 3.9 mL of sterile diluent (bacteriostatic water for injection containing 1.8% w/v benzyl alcohol) to a final concentration of 4 mg/mL.[4] No other diluent should be used.[4]
- Dosage and Administration:
  - Administer a dose of 0.4 mg/kg body weight intravenously (IV) once daily for three consecutive days.[5][13]
  - The IV injection can be given as a bolus over 15 seconds to 1 minute.[4]
- Supportive Care:
  - Provide standard supportive care, including fluid therapy, antiemetics, pain management, and nutritional support, as clinically indicated.[7]
- Monitoring:
  - Clinical signs are assessed daily using the Modified Canine Activity Index (MCAI), which scores activity, appetite, vomiting, cranial abdominal pain, dehydration, stool consistency, and the presence of blood in the stool.[7][12]

## Visualizations

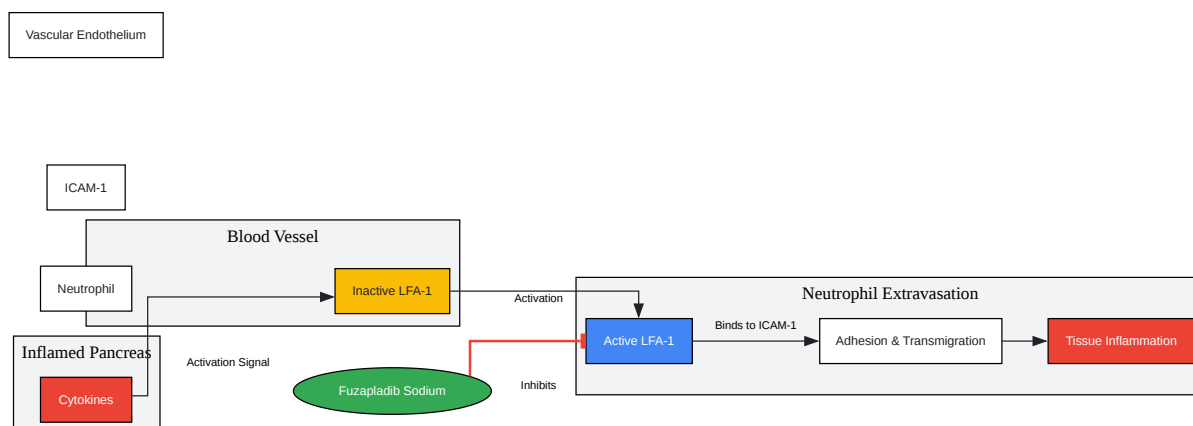

[Click to download full resolution via product page](#)

Caption: **Fuzapladib Sodium's** Mechanism of Action.

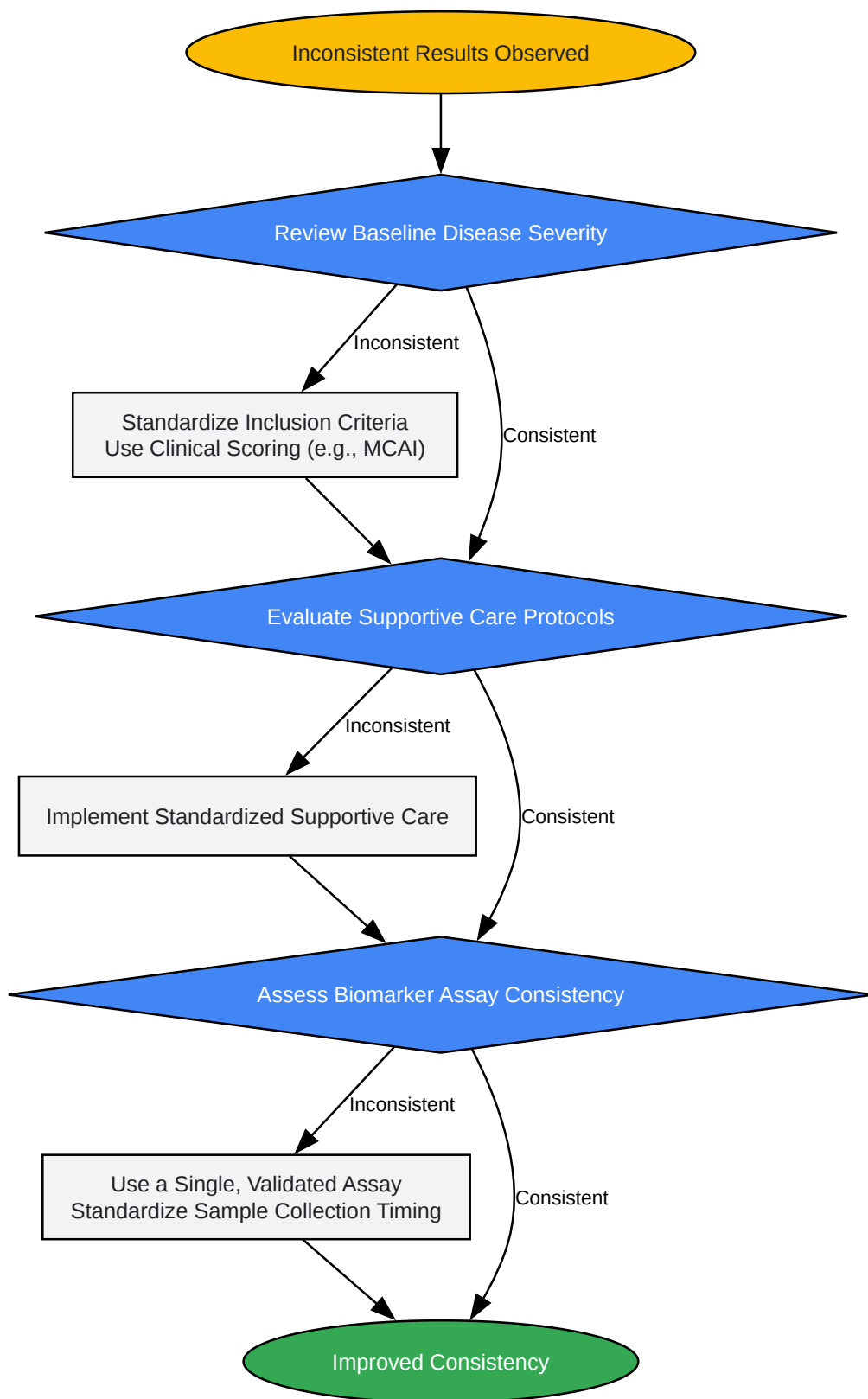

[Click to download full resolution via product page](#)

Caption: Troubleshooting Workflow for Inconsistent Results.

### Need Custom Synthesis?

BenchChem offers custom synthesis for rare earth carbides and specific isotopic labeling.

Email: [info@benchchem.com](mailto:info@benchchem.com) or [Request Quote Online](#).

## References

- [1. todaysveterinarypractice.com](https://todaysveterinarypractice.com) [[todaysveterinarypractice.com](https://todaysveterinarypractice.com)]
- [2. researchgate.net](https://researchgate.net) [[researchgate.net](https://researchgate.net)]
- [3. PANOQUELL®-CA1 \(fuzapladib sodium for injection\) is now available in the U.S. / News Releases & Articles About Ceva / News & Media / Ceva USA](#) [[ceva.us](https://ceva.us)]
- [4. PANOQUELL®-CA1](https://panoquell.com) [[panoquell.com](https://panoquell.com)]
- [5. Fuzapladib in a randomized controlled multicenter masked study in dogs with presumptive acute onset pancreatitis - PMC](#) [[pmc.ncbi.nlm.nih.gov](https://pubmed.ncbi.nlm.nih.gov)]
- [6. medcraveonline.com](https://medcraveonline.com) [[medcraveonline.com](https://medcraveonline.com)]
- [7. dvm360.com](https://dvm360.com) [[dvm360.com](https://dvm360.com)]
- [8. Fuzapladib - Drug Targets, Indications, Patents - Synapse](#) [[synapse-patsnap-com.libproxy1.nus.edu.sg](https://synapse-patsnap-com.libproxy1.nus.edu.sg)]
- [9. Species differences in the biopharmaceutical properties of fuzapladib sodium monohydrate in rats, cats, and dogs - MedCrave online](#) [[medcraveonline.com](https://medcraveonline.com)]
- [10. Response to letter regarding “Fuzapladib in a randomized controlled multicenter masked study in dogs with presumptive acute onset pancreatitis” - PMC](#) [[pmc.ncbi.nlm.nih.gov](https://pubmed.ncbi.nlm.nih.gov)]
- [11. Fuzapladib in a randomized controlled multicenter masked study in dogs with presumptive acute onset pancreatitis - PubMed](#) [[pubmed.ncbi.nlm.nih.gov](https://pubmed.ncbi.nlm.nih.gov)]
- [12. PANOQUELL®-CA1](https://panoquell.com) [[panoquell.com](https://panoquell.com)]
- [13. animaldrugsatfda.fda.gov](https://animaldrugsatfda.fda.gov) [[animaldrugsatfda.fda.gov](https://animaldrugsatfda.fda.gov)]
- To cite this document: BenchChem. [Navigating Fuzapladib Sodium Research: A Guide to Consistent Results]. BenchChem, [2026]. [Online PDF]. Available at: [<https://www.benchchem.com/product/b15605571/docs#navigating-fuzapladib-sodium-research-a-guide-to-consistent-results>]

---

### Disclaimer & Data Validity:

The information provided in this document is for Research Use Only (RUO) and is strictly not intended for diagnostic or therapeutic procedures. While BenchChem strives to provide accurate protocols, we make no warranties, express or implied, regarding the fitness of this product for every specific experimental setup.

**Technical Support:** The protocols provided are for reference purposes. Unsure if this reagent suits your experiment?

**Need Industrial/Bulk Grade?** [Request Custom Synthesis Quote](#)

## BenchChem

Our mission is to be the trusted global source of essential and advanced chemicals, empowering scientists and researchers to drive progress in science and industry.

### Contact

Address: 3281 E Guasti Rd  
Ontario, CA 91761, United States  
Phone: (601) 213-4426  
Email: [info@benchchem.com](mailto:info@benchchem.com)

[Contact our Ph.D. Support Team for a compatibility check](#)