

Application Notes and Protocols: Flow Cytometry Analysis of Cells Treated with SR18662

Author: BenchChem Technical Support Team. **Date:** April 2026

Compound of Interest

Compound Name: SR18662
Cat. No.: B15605137

[Get Quote](#)

Audience: Researchers, scientists, and drug development professionals.

Introduction

SR18662 is a potent small molecule inhibitor of Krüppel-like factor 5 (KLF5), a transcription factor implicated in the progression of various cancers, including colorectal cancer.^{[1][2][3][4]} Treatment of cancer cells with **SR18662** has been shown to reduce cell viability and proliferation by inducing cell cycle arrest and apoptosis.^{[1][2]} Flow cytometry is an essential tool for quantifying these cellular responses. These application notes provide detailed protocols for the analysis of apoptosis and cell cycle distribution in cells treated with **SR18662**.

Mechanism of Action of SR18662

SR18662 exerts its anti-cancer effects by inhibiting KLF5, which in turn downregulates key signaling pathways involved in cell growth and survival.^{[1][2][3]} Specifically, **SR18662** has been shown to inhibit the MAPK and WNT/ β -catenin signaling pathways.^{[1][2]} This disruption of normal signaling cascades leads to a decrease in the expression of cyclins, proteins crucial for cell cycle progression, ultimately causing cells to arrest in the S or G2/M phase of the cell

cycle.[1][2] Furthermore, **SR18662** treatment promotes programmed cell death, or apoptosis.[1][2]

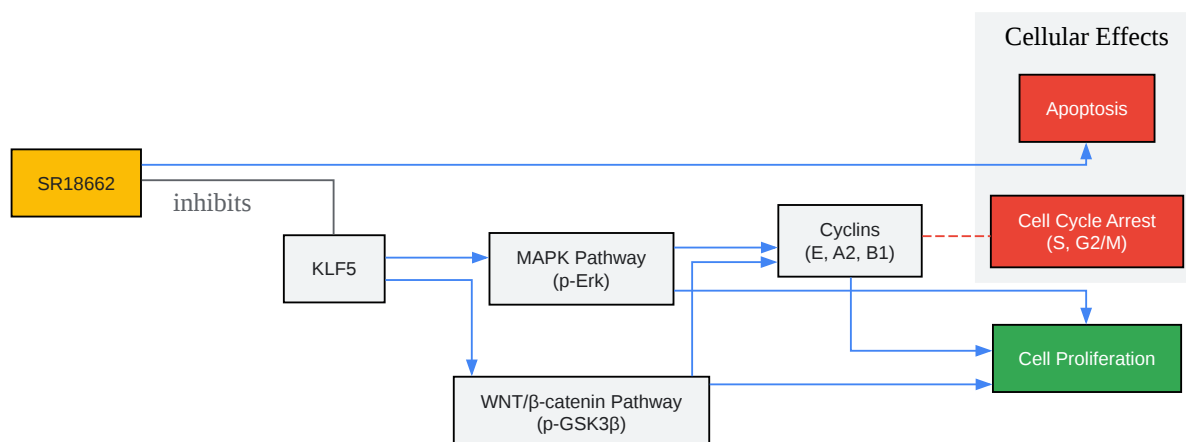

[Click to download full resolution via product page](#)

Caption: **SR18662** signaling pathway.

Quantitative Data Summary

The following tables summarize the quantitative effects of **SR18662** on colorectal cancer cell lines (DLD-1 and HCT116) as determined by flow cytometry.

Table 1: Effect of **SR18662** on Cell Cycle Distribution in DLD-1 Cells[1]

Treatment (10 μ M)	Duration	% G0/G1 Phase	% S Phase	% G2/M Phase
DMSO (Control)	24h	65.1 \pm 1.2	22.3 \pm 0.8	12.6 \pm 0.5
	48h	63.8 \pm 1.5	23.1 \pm 0.9	13.1 \pm 0.6
	72h	62.5 \pm 1.8	24.0 \pm 1.1	13.5 \pm 0.7
SR18662	24h	55.2 \pm 1.4	28.9 \pm 1.0**	15.9 \pm 0.8*
	48h	48.7 \pm 1.7	32.5 \pm 1.2	18.8 \pm 1.0**
	72h	40.1 \pm 2.0	35.8 \pm 1.5	24.1 \pm 1.3

*p < 0.05, **p < 0.01, ***p < 0.001 compared to DMSO control. Data are presented as mean \pm SEM (n=3).

Table 2: Effect of **SR18662** on Apoptosis in DLD-1 Cells[1]

Treatment (10 μ M)	Duration	% Healthy Cells	% Early Apoptosis	% Late Apoptosis/Dead
DMSO (Control)	24h	95.2 \pm 0.5	2.1 \pm 0.2	2.7 \pm 0.3
	48h	94.8 \pm 0.6	2.5 \pm 0.3	2.7 \pm 0.4
	72h	94.1 \pm 0.8	2.9 \pm 0.4	3.0 \pm 0.5
SR18662	24h	85.3 \pm 1.1	8.2 \pm 0.7	6.5 \pm 0.6**
	48h	72.1 \pm 1.5	15.4 \pm 1.0	12.5 \pm 0.9
	72h	55.6 \pm 2.2	22.8 \pm 1.4	21.6 \pm 1.3

***p < 0.001 compared to DMSO control. Data are presented as mean \pm SEM (n=3).

Experimental Protocols

Detailed methodologies for cell treatment and subsequent flow cytometry analysis are provided below.

Protocol 1: Cell Treatment with SR18662

This protocol describes the treatment of colorectal cancer cell lines with **SR18662** prior to flow cytometry analysis.

Materials:

- Colorectal cancer cell lines (e.g., DLD-1, HCT116)
- Complete cell culture medium (e.g., RPMI-1640 with 10% FBS)
- **SR18662** (stock solution in DMSO)
- DMSO (vehicle control)
- 6-well plates
- Incubator (37°C, 5% CO₂)

Procedure:

- Seed cells in 6-well plates at a density that will allow for logarithmic growth for the duration of the experiment.
- Allow cells to adhere and grow for 24 hours in a 37°C, 5% CO₂ incubator.
- Prepare working solutions of **SR18662** in complete cell culture medium. A common concentration range to test is 1 µM to 10 µM.^[1] Prepare a vehicle control with the same final concentration of DMSO as the highest **SR18662** concentration.
- Remove the medium from the wells and replace it with the medium containing **SR18662** or the vehicle control.
- Incubate the cells for the desired time points (e.g., 24, 48, and 72 hours).^[1]

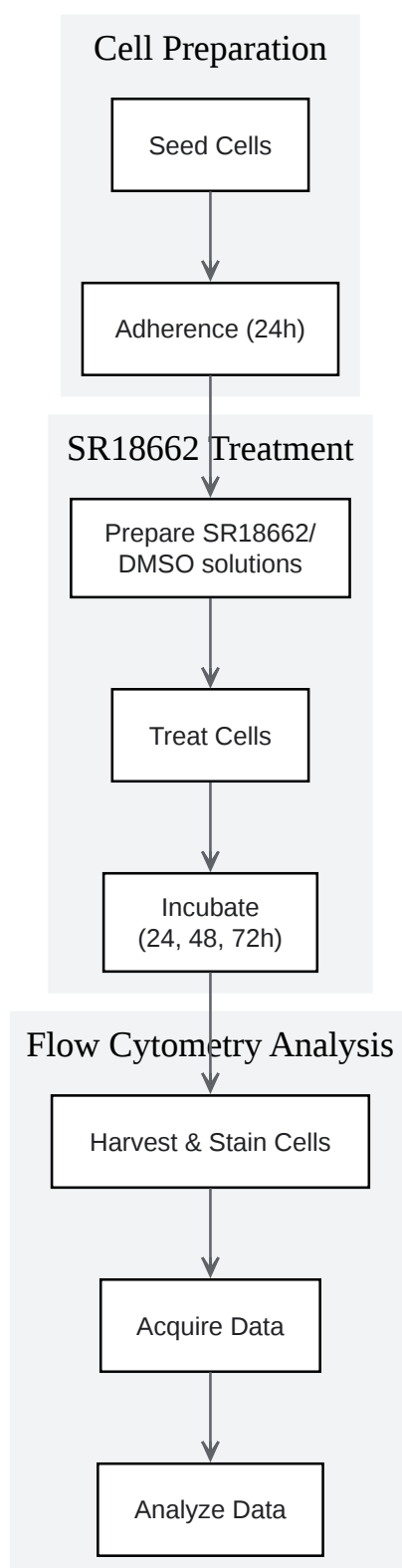

[Click to download full resolution via product page](#)

Caption: Experimental workflow.

Protocol 2: Apoptosis Analysis by Flow Cytometry

This protocol utilizes an Annexin V and a dead cell stain to differentiate between healthy, early apoptotic, and late apoptotic/dead cells.

Materials:

- Treated and control cells from Protocol 1
- Phosphate-buffered saline (PBS)
- Trypsin-EDTA
- Annexin V-FITC (or other fluorochrome) Apoptosis Detection Kit (containing Annexin V, a dead cell stain like Propidium Iodide (PI) or 7-AAD, and Binding Buffer)
- Flow cytometer

Procedure:

- Harvest the cells by trypsinization. Collect both adherent and floating cells to include apoptotic bodies.
- Wash the cells twice with cold PBS by centrifuging at 300 x g for 5 minutes and resuspending the pellet.
- Resuspend the cells in 1X Binding Buffer at a concentration of 1×10^6 cells/mL.
- Transfer 100 μ L of the cell suspension (1×10^5 cells) to a flow cytometry tube.
- Add 5 μ L of Annexin V-FITC and 5 μ L of the dead cell stain (e.g., PI).
- Gently vortex the tubes and incubate for 15 minutes at room temperature in the dark.
- Add 400 μ L of 1X Binding Buffer to each tube.
- Analyze the samples on a flow cytometer within one hour.

Protocol 3: Cell Cycle Analysis by Flow Cytometry

This protocol uses a DNA-intercalating dye to determine the distribution of cells in different phases of the cell cycle.

Materials:

- Treated and control cells from Protocol 1
- Phosphate-buffered saline (PBS)
- Trypsin-EDTA
- 70% ethanol (ice-cold)
- Propidium Iodide (PI) staining solution (containing PI and RNase A)
- Flow cytometer

Procedure:

- Harvest the cells by trypsinization.
- Wash the cells twice with cold PBS by centrifuging at 300 x g for 5 minutes.
- Fix the cells by resuspending the pellet in 1 mL of ice-cold 70% ethanol while gently vortexing.
- Incubate the cells on ice for at least 30 minutes (or at -20°C for long-term storage).
- Centrifuge the fixed cells at 500 x g for 5 minutes and discard the ethanol.
- Wash the cells once with PBS.
- Resuspend the cell pellet in 500 µL of PI staining solution.
- Incubate for 30 minutes at room temperature in the dark.
- Analyze the samples on a flow cytometer. Use a linear scale for the DNA content histogram.

Data Analysis and Interpretation

Apoptosis Analysis:

- Healthy cells: Annexin V-negative and PI-negative.
- Early apoptotic cells: Annexin V-positive and PI-negative.
- Late apoptotic/dead cells: Annexin V-positive and PI-positive.

Cell Cycle Analysis:

- Analyze the DNA content histogram to quantify the percentage of cells in the G0/G1, S, and G2/M phases. The G0/G1 peak will have 2N DNA content, and the G2/M peak will have 4N DNA content. Cells in the S phase will have DNA content between 2N and 4N.

Conclusion

The protocols and data presented here provide a comprehensive guide for researchers investigating the cellular effects of **SR18662** using flow cytometry. This powerful technique allows for the precise quantification of apoptosis and cell cycle arrest, offering valuable insights into the mechanism of action of this promising anti-cancer compound.

Need Custom Synthesis?

BenchChem offers custom synthesis for rare earth carbides and specific isotopic labeling.

Email: info@benchchem.com or [Request Quote Online](#).

References

- [1. The novel small molecule SR18662 efficiently inhibits the growth of colorectal cancer in vitro and in vivo - PMC \[pmc.ncbi.nlm.nih.gov\]](#)
- [2. The Novel Small-Molecule SR18662 Efficiently Inhibits the Growth of Colorectal Cancer In Vitro and In Vivo - PubMed \[pubmed.ncbi.nlm.nih.gov\]](#)
- [3. medchemexpress.com \[medchemexpress.com\]](#)
- [4. aacrjournals.org \[aacrjournals.org\]](#)

- To cite this document: BenchChem. [Application Notes and Protocols: Flow Cytometry Analysis of Cells Treated with SR18662]. BenchChem, [2026]. [Online PDF]. Available at: [<https://www.benchchem.com/product/b15605137/docs#application-notes-and-protocols-flow-cytometry-analysis-of-cells-treated-with-sr18662>]

Disclaimer & Data Validity:

The information provided in this document is for Research Use Only (RUO) and is strictly not intended for diagnostic or therapeutic procedures. While BenchChem strives to provide accurate protocols, we make no warranties, express or implied, regarding the fitness of this product for every specific experimental setup.

Technical Support: The protocols provided are for reference purposes. Unsure if this reagent suits your experiment?

Need Industrial/Bulk Grade? [Request Custom Synthesis Quote](#)

BenchChem

Our mission is to be the trusted global source of essential and advanced chemicals, empowering scientists and researchers to drive progress in science and industry.

Contact

Address: 3281 E Guasti Rd
Ontario, CA 91761, United States
Phone: (601) 213-4426
Email: info@benchchem.com

[Contact our Ph.D. Support Team for a compatibility check](#)