

A Technical Guide to PC Biotin-PEG3-Azide for Advanced Proteomics

Author: BenchChem Technical Support Team. **Date:** April 2026

Compound of Interest

Compound Name: PC Biotin-PEG3-azide

Cat. No.: B15605821

[Get Quote](#)

For Researchers, Scientists, and Drug Development Professionals

Introduction

In the dynamic field of proteomics, the precise identification and quantification of proteins within complex biological systems is paramount. Chemical proteomics, a sub-discipline that employs chemical probes to study protein function, has been significantly advanced by the development of sophisticated reagents. Among these, **PC Biotin-PEG3-azide** has emerged as a powerful tool for activity-based protein profiling (ABPP) and target identification. This technical guide provides an in-depth overview of the key features of **PC Biotin-PEG3-azide**, detailed experimental protocols for its application, and a comparative analysis of its performance, empowering researchers to effectively integrate this reagent into their proteomics workflows.

At its core, **PC Biotin-PEG3-azide** is a trifunctional molecule designed for the selective enrichment and subsequent release of tagged biomolecules.^[1] It consists of three key moieties:

- A Photocleavable (PC) Linker: This enables the gentle release of captured proteins using UV light, overcoming the harsh elution conditions typically required for the strong biotin-streptavidin interaction.^{[2][3][4][5]}

- A Biotin Tag: This provides a high-affinity handle for the efficient capture of labeled proteins using streptavidin- or avidin-conjugated beads.[1]
- An Azide Group: This reactive handle allows for the covalent attachment of the probe to alkyne-modified proteins via the highly efficient and bioorthogonal copper(I)-catalyzed azide-alkyne cycloaddition (CuAAC) or strain-promoted alkyne-azide cycloaddition (SPAAC) "click chemistry" reactions.[5][6][7]

The inclusion of a PEG3 (triethylene glycol) spacer enhances the water solubility of the reagent and reduces steric hindrance, facilitating efficient labeling and capture.[1][5][7]

Key Features and Advantages in Proteomics

The unique combination of features in **PC Biotin-PEG3-azide** offers several distinct advantages for proteomics research:

- Mild Elution Conditions: The ability to cleave the linker with UV light (typically around 365 nm) allows for the recovery of captured proteins under non-denaturing conditions.[8][9] This is a significant improvement over traditional methods that rely on boiling in SDS-containing buffers or enzymatic digestion directly on the beads, which can lead to co-elution of contaminants and incomplete protein recovery.[3][4][5]
- Reduced Contamination in Mass Spectrometry: By avoiding the harsh elution methods that can release non-specifically bound proteins and peptides from the streptavidin beads, **PC Biotin-PEG3-azide** provides cleaner samples for downstream mass spectrometry analysis. This leads to improved signal-to-noise ratios and more confident protein identifications.[3][4][5]
- Versatility in Application: The azide group's reactivity with alkynes makes this reagent compatible with a wide range of metabolic labeling strategies. Researchers can introduce alkyne-bearing analogs of metabolites, amino acids, or other building blocks into cells or organisms to tag specific classes of proteins for subsequent analysis.
- Enhanced Solubility and Accessibility: The hydrophilic PEG3 spacer improves the reagent's solubility in aqueous buffers and extends the biotin moiety away from the labeled protein, enhancing its accessibility for binding to streptavidin.[1][5][7]

Quantitative Data and Comparative Analysis

While specific quantitative data for **PC Biotin-PEG3-azide** can be application-dependent, the following table provides a comparative overview of different types of cleavable linkers used in proteomics to highlight the advantages of the photocleavable approach.

Linker Type	Cleavage Condition	Advantages	Disadvantages	Small Residual Mass After Cleavage
Photocleavable (PC)	UV light (e.g., 365 nm)[8][9]	Very mild, reagent-free elution; Spatiotemporal control of cleavage possible.	Potential for UV-induced damage to sensitive proteins; Incomplete cleavage can occur.	Yes[4][5]
Acid-cleavable (e.g., DADPS)	Mild acid (e.g., 10% formic acid)	Efficient cleavage under relatively mild conditions.	Not suitable for acid-labile post-translational modifications.	Yes
Disulfide-based	Reducing agents (e.g., DTT, TCEP)	Mild cleavage conditions.	Potential for premature cleavage in the cellular reducing environment; May require alkylation of free thiols.	Yes
Diazobenzene-based	Sodium dithionite	Relatively mild cleavage.	The reducing agent may have side reactions with the proteome.	Yes

DADPS: Dialkoxydiphenylsilane; DTT: Dithiothreitol; TCEP: Tris(2-carboxyethyl)phosphine

One study on a similar photocleavable biotin phosphoramidite demonstrated that photorelease of the captured biomolecule was complete in approximately 4 minutes of irradiation with 300-350 nm light. Another study using a photocleavable 2-nitrobenzyl linker showed that close to 80% of an immobilized fluorescent DNA molecule was released after UV irradiation at 340 nm. [10] These findings suggest that the photocleavage process can be both rapid and efficient.

Experimental Protocols

The following sections provide detailed methodologies for the key steps in a typical chemoproteomics workflow using **PC Biotin-PEG3-azide**.

Protein Labeling via Copper(I)-Catalyzed Azide-Alkyne Cycloaddition (CuAAC) in Cell Lysate

This protocol describes the labeling of alkyne-modified proteins in a cell lysate with **PC Biotin-PEG3-azide**.

Materials:

- Cell lysate containing alkyne-modified proteins (1-5 mg/mL)
- **PC Biotin-PEG3-azide** (10 mM stock in DMSO)
- Tris(3-hydroxypropyltriazolylmethyl)amine (THPTA) (100 mM in water)
- Copper(II) sulfate (CuSO₄) (50 mM in water)
- Sodium ascorbate (100 mM in water, freshly prepared)
- Phosphate-buffered saline (PBS)
- Protease inhibitors

Procedure:

- Thaw the cell lysate on ice. Add protease inhibitors to the lysate.
- In a microcentrifuge tube, combine the following in order:

- 50 μ L of cell lysate
- PBS to a final volume of 180 μ L
- 4 μ L of **PC Biotin-PEG3-azide** stock solution (final concentration 200 μ M)
- Vortex the mixture gently.
- Add 10 μ L of 100 mM THPTA solution.
- Add 10 μ L of 50 mM CuSO₄ solution.
- Initiate the click reaction by adding 10 μ L of freshly prepared 100 mM sodium ascorbate.
- Vortex the reaction mixture gently and incubate at room temperature for 1-2 hours with gentle rotation.
- The protein lysate is now ready for the enrichment step.

Enrichment of Biotinylated Proteins using Streptavidin Beads

This protocol outlines the capture of biotinylated proteins from the cell lysate using streptavidin-conjugated magnetic beads.

Materials:

- Labeled cell lysate from the previous step
- Streptavidin-conjugated magnetic beads
- Lysis buffer (e.g., RIPA buffer: 50 mM Tris-HCl pH 7.4, 150 mM NaCl, 1% NP-40, 0.5% sodium deoxycholate, 0.1% SDS)
- Wash Buffer 1 (2% SDS in PBS)
- Wash Buffer 2 (1 M KCl)
- Wash Buffer 3 (0.1 M Na₂CO₃)

- Wash Buffer 4 (2 M Urea in 10 mM Tris-HCl, pH 8.0)
- PBS

Procedure:

- Equilibrate the required amount of streptavidin magnetic beads by washing them three times with lysis buffer.
- Add the labeled cell lysate to the equilibrated beads.
- Incubate the mixture overnight at 4°C with gentle rotation to allow for efficient binding.
- Pellet the beads using a magnetic stand and discard the supernatant.
- Wash the beads sequentially with the following buffers, with each wash step involving resuspension of the beads, incubation for 5-10 minutes at 4°C with rotation, followed by pelleting and removal of the supernatant:
 - Twice with Lysis Buffer
 - Once with Wash Buffer 1
 - Once with Wash Buffer 2
 - Once with Wash Buffer 3
 - Once with Wash Buffer 4
 - Three times with PBS to remove any residual detergents and salts.

Photocleavage and Elution of Captured Proteins

This protocol describes the release of the captured proteins from the streptavidin beads by UV irradiation.

Materials:

- Beads with bound biotinylated proteins from the previous step

- Ammonium bicarbonate buffer (50 mM, pH 8.0)
- UV lamp (365 nm, e.g., a Black Ray UV lamp)

Procedure:

- After the final PBS wash, resuspend the beads in 50-100 μ L of 50 mM ammonium bicarbonate buffer.
- Transfer the bead suspension to a UV-transparent microcentrifuge tube.
- Place the tube on ice at a distance of approximately 1-5 cm from the UV lamp.
- Irradiate the sample with 365 nm UV light for 30-60 minutes. The optimal time may need to be determined empirically. Gentle agitation during irradiation can improve cleavage efficiency.
- After irradiation, pellet the beads using a magnetic stand.
- Carefully collect the supernatant containing the eluted proteins. This eluate is now ready for downstream analysis, such as SDS-PAGE or preparation for mass spectrometry.

Sample Preparation for Mass Spectrometry

This protocol provides a general workflow for preparing the eluted proteins for analysis by mass spectrometry.

Materials:

- Eluted protein sample
- Dithiothreitol (DTT) (1 M stock)
- Iodoacetamide (IAA) (500 mM stock, freshly prepared in the dark)
- Trypsin (mass spectrometry grade)
- Formic acid

- C18 desalting spin tips

Procedure:

- Reduction: Add DTT to the eluted protein sample to a final concentration of 10 mM. Incubate at 56°C for 30 minutes.
- Alkylation: Cool the sample to room temperature. Add IAA to a final concentration of 20 mM. Incubate in the dark at room temperature for 30 minutes.
- Digestion: Add trypsin to the protein sample at a ratio of 1:50 (trypsin:protein, w/w). Incubate overnight at 37°C.
- Quenching: Stop the digestion by adding formic acid to a final concentration of 1%.
- Desalting: Desalt the peptide mixture using C18 spin tips according to the manufacturer's protocol.
- Analysis: The desalted peptides are now ready for analysis by LC-MS/MS.

Visualizations

Experimental Workflow for Proteomics using PC Biotin-PEG3-Azide

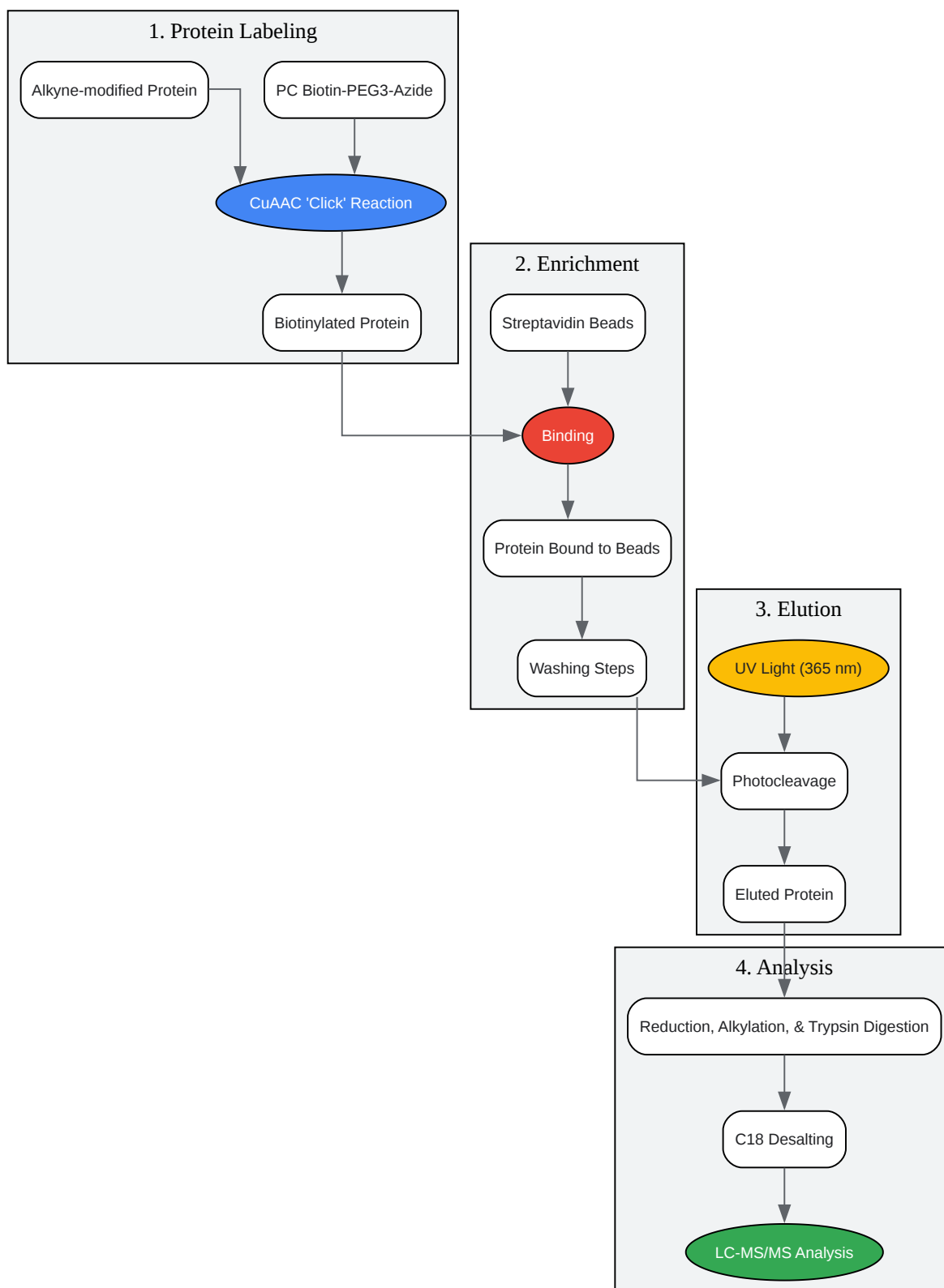

[Click to download full resolution via product page](#)

Caption: General experimental workflow for proteomics using **PC Biotin-PEG3-azide**.

Logical Relationship of PC Biotin-PEG3-Azide Components

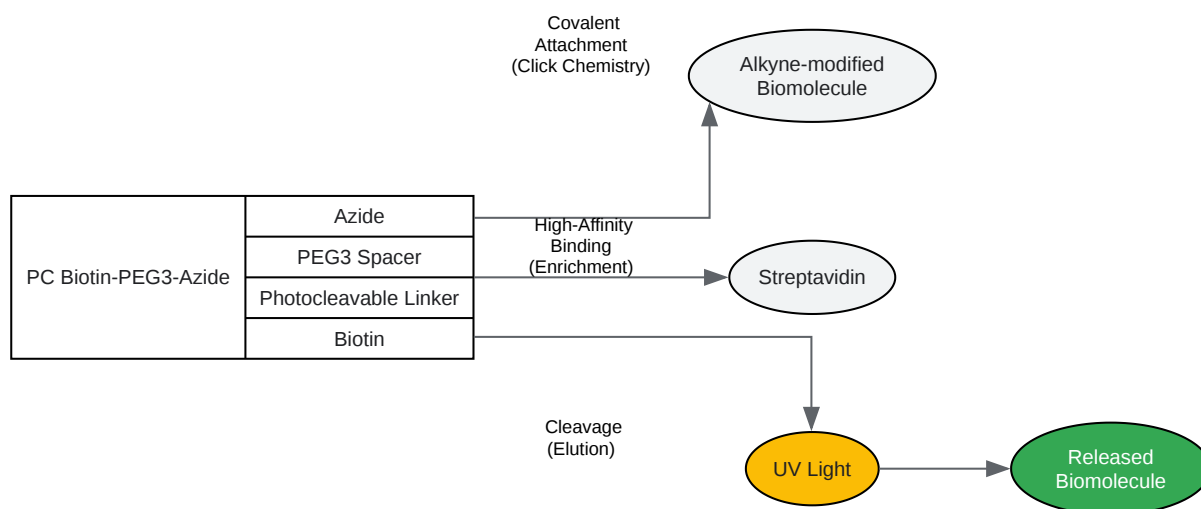

[Click to download full resolution via product page](#)

Caption: Functional relationships of the core components of **PC Biotin-PEG3-azide**.

Conclusion

PC Biotin-PEG3-azide is a versatile and powerful reagent that addresses a key challenge in affinity-based proteomics: the efficient and gentle elution of captured proteins. By combining the specificity of click chemistry, the high affinity of the biotin-streptavidin interaction, and the mild release mechanism of a photocleavable linker, this tool enables cleaner and more reliable identification and quantification of proteins from complex mixtures. The detailed protocols and conceptual diagrams provided in this guide are intended to equip researchers with the knowledge needed to successfully apply **PC Biotin-PEG3-azide** in their pursuit of novel biological discoveries. As proteomics continues to evolve, the use of such sophisticated chemical tools will undoubtedly play a crucial role in unraveling the complexities of the proteome.

Need Custom Synthesis?

BenchChem offers custom synthesis for rare earth carbides and specific isotopic labeling.

Email: info@benchchem.com or [Request Quote Online](#).

References

- [1. Purification of biotinylated proteins on streptavidin resin: A protocol for quantitative elution | Semantic Scholar \[semanticscholar.org\]](#)
- [2. broadpharm.com \[broadpharm.com\]](#)
- [3. EP3250928A1 - Methods for a quantitative release of biotinylated peptides and proteins from streptavidin complexes - Google Patents \[patents.google.com\]](#)
- [4. Chemoproteomic Selectivity Profiling of PI3K and PI3K Kinase Inhibitors - PubMed \[pubmed.ncbi.nlm.nih.gov\]](#)
- [5. academic.oup.com \[academic.oup.com\]](#)
- [6. vectorlabs.com \[vectorlabs.com\]](#)
- [7. Sample Preparation | Stanford University Mass Spectrometry \[mass-spec.stanford.edu\]](#)
- [8. Benchmarking and Automating the Biotinylation Proteomics Workflow - PMC \[pmc.ncbi.nlm.nih.gov\]](#)
- [9. Copper-Catalyzed Azide–Alkyne Click Chemistry for Bioconjugation - PMC \[pmc.ncbi.nlm.nih.gov\]](#)
- [10. Photocleavage of a 2-nitrobenzyl linker bridging a fluorophore to the 5' end of DNA - PubMed \[pubmed.ncbi.nlm.nih.gov\]](#)
- To cite this document: BenchChem. [A Technical Guide to PC Biotin-PEG3-Azide for Advanced Proteomics]. BenchChem, [2026]. [Online PDF]. Available at: [\[https://www.benchchem.com/product/b15605821/docs#a-technical-guide-to-pc-biotin-peg3-azide-for-advanced-proteomics\]](https://www.benchchem.com/product/b15605821/docs#a-technical-guide-to-pc-biotin-peg3-azide-for-advanced-proteomics)

Disclaimer & Data Validity:

The information provided in this document is for Research Use Only (RUO) and is strictly not intended for diagnostic or therapeutic procedures. While BenchChem strives to provide

accurate protocols, we make no warranties, express or implied, regarding the fitness of this product for every specific experimental setup.

Technical Support: The protocols provided are for reference purposes. Unsure if this reagent suits your experiment?

Need Industrial/Bulk Grade? [Request Custom Synthesis Quote](#)

BenchChem

Our mission is to be the trusted global source of essential and advanced chemicals, empowering scientists and researchers to drive progress in science and industry.

Contact

Address: 3281 E Guasti Rd

Ontario, CA 91761, United States

Phone: (601) 213-4426

Email: info@benchchem.com

[Contact our Ph.D. Support Team for a compatibility check](#)