

V-11-0711 Cross-Reactivity Profile: A Comparative Guide

Author: BenchChem Technical Support Team. **Date:** April 2026

Compound of Interest

Compound Name: V-11-0711
Cat. No.: B15604491

[Get Quote](#)

For Researchers, Scientists, and Drug Development Professionals

This guide provides a detailed comparison of the cross-reactivity profile of **V-11-0711**, a potent and selective inhibitor of Choline Kinase α (ChoK α), against other kinases. The information is compiled from publicly available experimental data to offer an objective resource for evaluating its off-target effects and potential therapeutic applications.

Executive Summary

V-11-0711 is a novel small molecule inhibitor of Choline Kinase α (ChoK α) with a reported IC₅₀ of 20 nM.[1] It demonstrates notable selectivity for ChoK α over the β isoform, with an 11-fold lower activity against Choline Kinase β (ChoK β ; IC₅₀ of 220 nM).[1] Cross-reactivity studies are crucial for understanding the specificity of a kinase inhibitor and predicting potential off-target effects. This guide summarizes the available data on the cross-reactivity of **V-11-0711** and provides the relevant experimental protocols for context.

Comparative Kinase Inhibition Profile

To assess the selectivity of **V-11-0711**, a cross-reactivity screening was performed against a panel of 50 kinases using the Merck Millipore KinaseProfiler™ service. The results indicated

that **V-11-0711** has excellent selectivity, with very little inhibition observed for the tested kinases at a concentration of 2 μM .^[1]

While the primary publication references a supplementary table (Supplementary Table S1) containing the detailed quantitative data of this 50-kinase panel screening, this specific supplementary file could not be retrieved in the conducted search. The following table is therefore based on the qualitative description from the main publication.

Kinase Target	V-11-0711 Inhibition at 2 μM	Alternative Selective Inhibitors	Primary Targets of Alternatives
ChoK α	Potent Inhibition (IC ₅₀ = 20 nM) ^[1]		
Panel of 50 other kinases	Minimal Inhibition ^[1]	Not Applicable	Not Applicable
ChoK β	Moderate Inhibition (IC ₅₀ = 220 nM) ^[1]		

Note: The specific 50 kinases screened and their respective inhibition values are not publicly available within the accessed resources. The data presented is a qualitative summary from the primary literature.

Experimental Protocols

The cross-reactivity of **V-11-0711** was assessed using a well-established method for kinase inhibitor profiling.

KinaseProfiler™ Assay (Radiometric)

Objective: To determine the inhibitory activity of **V-11-0711** against a broad panel of kinases.

Principle: This is a radiometric protein kinase assay that measures the transfer of the γ -phosphate of [γ -³³P]ATP to a protein or peptide substrate by a specific kinase. The amount of incorporated phosphate is quantified, and the inhibitory effect of a compound is determined by the reduction in this incorporation compared to a control.

General Procedure:

- **Reaction Setup:** Kinase reactions are set up in a multi-well plate format. Each well contains the specific kinase, its corresponding substrate (protein or peptide), and the necessary cofactors in a reaction buffer.
- **Compound Addition:** **V-11-0711** is added to the reaction wells at a specified concentration (in this case, 2 μ M). Control wells containing the solvent (e.g., DMSO) are also included.
- **Initiation of Reaction:** The kinase reaction is initiated by the addition of a mixture of non-radiolabeled ATP and [γ - 33 P]ATP.
- **Incubation:** The reaction mixtures are incubated at a controlled temperature for a defined period to allow for substrate phosphorylation.
- **Termination and Capture:** The reaction is stopped, and the phosphorylated substrate is captured onto a filter membrane. Unreacted [γ - 33 P]ATP is washed away.
- **Quantification:** The amount of radioactivity incorporated into the substrate on the filter is measured using a scintillation counter or a phosphorimager.
- **Data Analysis:** The percentage of remaining kinase activity in the presence of the inhibitor is calculated relative to the control wells.

Signaling Pathway and Experimental Workflow

ChoK α Signaling Pathway

Choline Kinase α is a key enzyme in the Kennedy pathway, responsible for the synthesis of phosphatidylcholine, a major component of cell membranes. Its activity is upstream of several important cellular processes and is known to be regulated by oncogenic signaling pathways such as Ras-Raf-MAPK and PI3K-Akt.

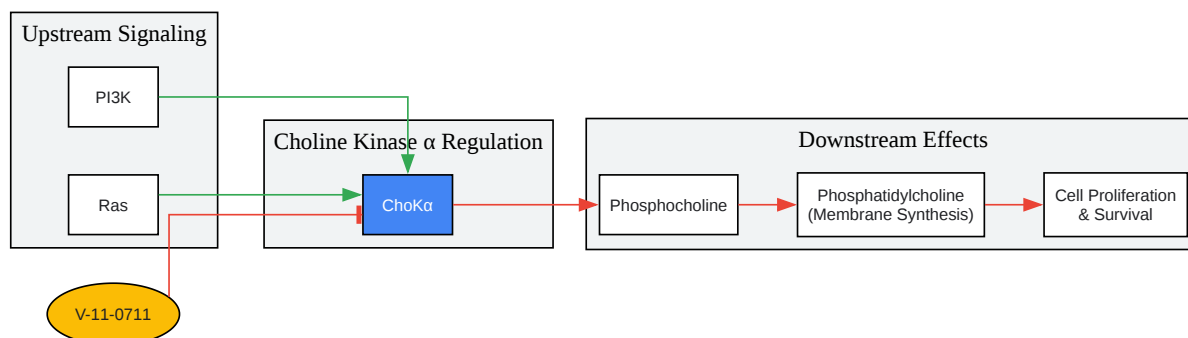

[Click to download full resolution via product page](#)

Caption: ChoK α is activated by Ras and PI3K pathways and catalyzes the production of phosphocholine.

Kinase Cross-Reactivity Experimental Workflow

The following diagram illustrates the typical workflow for assessing the cross-reactivity of a kinase inhibitor like **V-11-0711** using a kinase panel screening service.

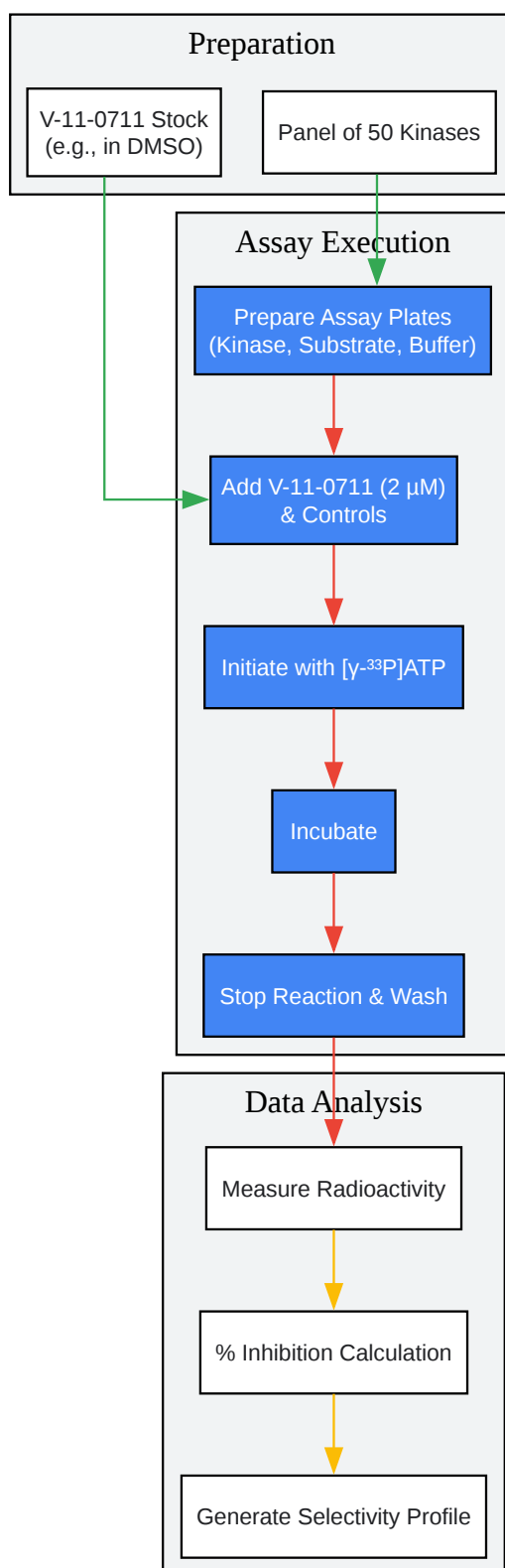

[Click to download full resolution via product page](#)

Caption: Workflow for kinase inhibitor cross-reactivity screening.

Need Custom Synthesis?

BenchChem offers custom synthesis for rare earth carbides and specific isotopic labeling.

Email: info@benchchem.com or [Request Quote Online](#).

References

- 1. A non-catalytic role of choline kinase alpha is important in promoting cancer cell survival - PMC [[pmc.ncbi.nlm.nih.gov](https://pubmed.ncbi.nlm.nih.gov/)]
- To cite this document: BenchChem. [V-11-0711 Cross-Reactivity Profile: A Comparative Guide]. BenchChem, [2026]. [Online PDF]. Available at: [<https://www.benchchem.com/product/b15604491/docs#v-11-0711-cross-reactivity-profile-a-comparative-guide>]

Disclaimer & Data Validity:

The information provided in this document is for Research Use Only (RUO) and is strictly not intended for diagnostic or therapeutic procedures. While BenchChem strives to provide accurate protocols, we make no warranties, express or implied, regarding the fitness of this product for every specific experimental setup.

Technical Support: The protocols provided are for reference purposes. Unsure if this reagent suits your experiment?

Need Industrial/Bulk Grade? [Request Custom Synthesis Quote](#)

BenchChem

Our mission is to be the trusted global source of essential and advanced chemicals, empowering scientists and researchers to drive progress in science and industry.

Contact

Address: 3281 E Guasti Rd
Ontario, CA 91761, United States
Phone: (601) 213-4426
Email: info@benchchem.com

Contact our Ph.D. Support Team for a compatibility check